

Energy Levels of Light Nuclei $A = 10$

F. Ajzenberg-Selove

University of Pennsylvania, Philadelphia, Pennsylvania 19104-6396

Abstract: An evaluation of $A = 5-10$ was published in *Nuclear Physics A490* (1988), p. 1. This version of $A = 10$ differs from the published version in that we have corrected some errors discovered after the article went to press. The introduction and introductory tables have been omitted from this manuscript. [Reference](#) key numbers have been changed to the NNDC/TUNL format.

(References closed June 1, 1988)

The original work of Fay Ajzenberg-Selove was supported by the US Department of Energy [DE-FG02-86ER40279]. Later modification by the TUNL Data Evaluation group was supported by the US Department of Energy, Office of High Energy and Nuclear Physics, under: Contract No. DEFG05-88-ER40441 (North Carolina State University); Contract No. DEFG05-91-ER40619 (Duke University).

Table of Contents for $A = 10$

Below is a list of links for items found within the PDF document. The introductory [Table 2](#) is available on this website via the link.

A. Nuclides: [\$^{10}\text{n}\$](#) , [\$^{10}\text{He}\$](#) , [\$^{10}\text{Li}\$](#) , [\$^{10}\text{Be}\$](#) , [\$^{10}\text{B}\$](#) , [\$^{10}\text{C}\$](#) , [\$^{10}\text{N}\$](#) , [\$^{10}\text{O}\$](#) , [\$^{10}\text{F}\$](#) , [\$^{10}\text{Ne}\$](#)

B. Tables of Recommended Level Energies:

[Table 10.1](#): Energy levels of ^{10}Be

[Table 10.5](#): Energy levels of ^{10}B

[Table 10.18](#): Energy levels of ^{10}C

C. [References](#)

D. Figures: [\$^{10}\text{Be}\$](#) , [\$^{10}\text{B}\$](#) , [\$^{10}\text{C}\$](#) , [Isobar diagram](#)

E. Erratum to the Publication: [PS](#) or [PDF](#)

¹⁰n
(Not illustrated)

¹⁰n has not been observed: see (1979AJ01). See also (1986AB10; theor.).

¹⁰He
(Not illustrated)

¹⁰He has not been observed. It has been searched for in the spontaneous fission of ²⁵²Cf (1982AL33), in the fragmentation of 0.79 GeV/A ¹¹Li ions (1987KO1Y) and in the fragmentation of a 30 MeV/A ¹⁸O beam (1988ST06). The production rate in the latter experiment is $< 3 \times 10^{-5}$ of the measured production probability of ⁸He (1988ST06). See also (1984AJ01). The calculated value of the atomic mass excess of ¹⁰He is 48.92 ± 0.14 MeV: ¹⁰He is then unstable with respect to breakup into ⁹He + n and ⁸He + 2n by 0.04 and 1.18 MeV, respectively (1988BRZZ). See also (1984BE1C), (1979AJ01, 1984AJ01, 1987FL1A, 1987HA1R, 1987PE1C, 1987SE05) and (1983ANZQ, 1983PO1A, 1984VA06, 1985PO10, 1985SA32, 1986SA30, 1987BL18, 1987SA15; theor.).

¹⁰Li
(Fig. 4)

At $E(^9\text{Be}) = 121$ MeV, ¹⁰Li has been observed in the ⁹Be(⁹Be, ⁸B)¹⁰Li reaction with a differential cross section (c.m.) of ≈ 30 nb/sr at $\theta = 14^\circ$ (lab): $Q_0 = -34.06 \pm 0.25$ MeV, and the atomic mass excess of ¹⁰Li is 33.83 ± 0.25 MeV if the group observed ($\Gamma \approx 1.2 \pm 0.3$ MeV) corresponds to the ground state. ¹⁰Li_{g.s.} would then be unbound with respect to breakup into ⁹Li + n by 0.80 ± 0.25 MeV: see (1979AJ01). See also (1986GI10, 1987AB15), (1984AJ01, 1985AL1G, 1987PE1C) and (1982KA1D, 1983ANZQ, 1983FE07, 1984VA06, 1985PO10, 1986AB10, 1988POZS; theor.).

¹⁰Be
(Figs. 1 and 4)

GENERAL: See also (1984AJ01).

Model calculations: (1983MI1E, 1983SH38, 1984NI12, 1984VA06, 1985KW02).

Special states: (1984NI12, 1984VA06, 1987AB1H, 1987BL18).

Electromagnetic transitions: (1984NI12).

Astrophysical questions: (1984BE1F, 1984EN1A, 1984NE1D, 1984SA1D, 1985WE1A, 1987EL1E, 1987GR1Q, 1987NA1M, 1987SO1E, 1988BE1B, 1988FE1A, 1988HA1M).

Complex reactions involving ^{10}Be : (1983EN04, 1983OL1A, 1983WI1A, 1984GR08, 1984HI1A, 1984ST1B, 1985JA18, 1985MA13, 1985PO11, 1985TA18, 1985TR1B, 1986AN1F, 1986AV1B, 1986BA69, 1986CS1A, 1986HA1B, 1986ME06, 1986PO06, 1986SA30, 1986SIZS, 1986SO10, 1986WE1E, 1987AR19, 1987BA38, 1987BA39, 1987CH26, 1987DE37, 1987FE1A, 1987GR11, 1987GU04, 1987JA06, 1987KI05, 1987NA01, 1987TAZU, 1987TR05, 1987VI02, 1987VI14, 1987WA09, 1987YA16, 1988BL09, 1988CA06, 1988KI05, 1988KR11, 1988RU01, 1988SA19).

Applications: (1983FA1B, 1983KU1C, 1983LI1A, 1983NE1A, 1983SH1G, 1983TU1A, 1984BE1F, 1984BE1H, 1984BO1E, 1984DO1B, 1984EL1B, 1984EL1C, 1984EN1A, 1984HE1B, 1984HE1C, 1984HO1E, 1984IM1A, 1984KL1A, 1984MA1K, 1984MI1D, 1984NE1C, 1984NE1E, 1984PO1C, 1984RA1D, 1984SE1B, 1984SE1D, 1984SH1L, 1984SO1A, 1984SO1B, 1984SP1B, 1984SU1B, 1984TU1A, 1984TU1C, 1984VA1D, 1985BE1D, 1985RA1A, 1985YI1A, 1986NI1A, 1986SU1H, 1986TE1A, 1987BE1X, 1987BR1Q, 1987BR1U, 1987DE1P, 1987EI1A, 1987EL1E, 1987GO1W, 1987GR1Q, 1987IN1A, 1987JA1G, 1987KU1L, 1987LA1G, 1987LA1I, 1987MO1F, 1987NA1M, 1987OE1A, 1987RA1N, 1987RE1H, 1987SE1D, 1987SE1E, 1987SH1N, 1987VA1S).

Muon and neutrino capture and reactions: (1984KO24).

Reactions involving pions and kaons (See also reactions 3, 10, 15 and 17.): (1982BE1D, 1984KA1C, 1985BE1K, 1985TU1B, 1986BE1P, 1986RA16).

Hypernuclei: (1982KA1D, 1982WA1A, 1983BA1D, 1983FE07, 1983MI1E, 1983PO1D, 1984BO1D, 1984BO1G, 1984CH1G, 1984DZ1A, 1984ER1A, 1984KO1F, 1984SH1J, 1985AH1A, 1985IK1A, 1986AN1R, 1986BA1W, 1986BO1E, 1986DA1B, 1986MA1C, 1986PO1H, 1986WA1J, 1986ZH1B, 1987BO1L, 1987BO1O, 1987MI38, 1987PO1H, 1987WU05, 1988GI1B).

Other topics: (1984PO11, 1985AN28, 1985WI1B).

Fig. 1: Energy levels of ^{10}Be . In these diagrams, energy values are plotted vertically in MeV, based on the ground state as zero. Uncertain levels or transitions are indicated by dashed lines; levels which are known to be particularly broad are cross-hatched. Values of total angular momentum J , parity, and isobaric spin T which appear to be reasonably well established are indicated on the levels; less certain assignments are enclosed in parentheses. For reactions in which ^{10}Be is the compound nucleus, some typical thin-target excitation functions are shown schematically, with the yield plotted horizontally and the bombarding energy vertically. Bombarding energies are indicated in laboratory coordinates and plotted to scale in cm coordinates. Excited states of the residual nuclei involved in these reactions have generally not been shown; where transitions to such excited states are known to occur, a brace is sometimes used to suggest reference to another diagram. For reactions in which the present nucleus occurs as a residual product, excitation functions have not been shown; a vertical arrow with a number indicating some bombarding energy, usually the highest, at which the reaction has been studied, is used instead. Further information on the levels illustrated, including a listing of the reactions in which each has been observed, is contained in the master table, entitled "Energy levels of ^{10}Be ".

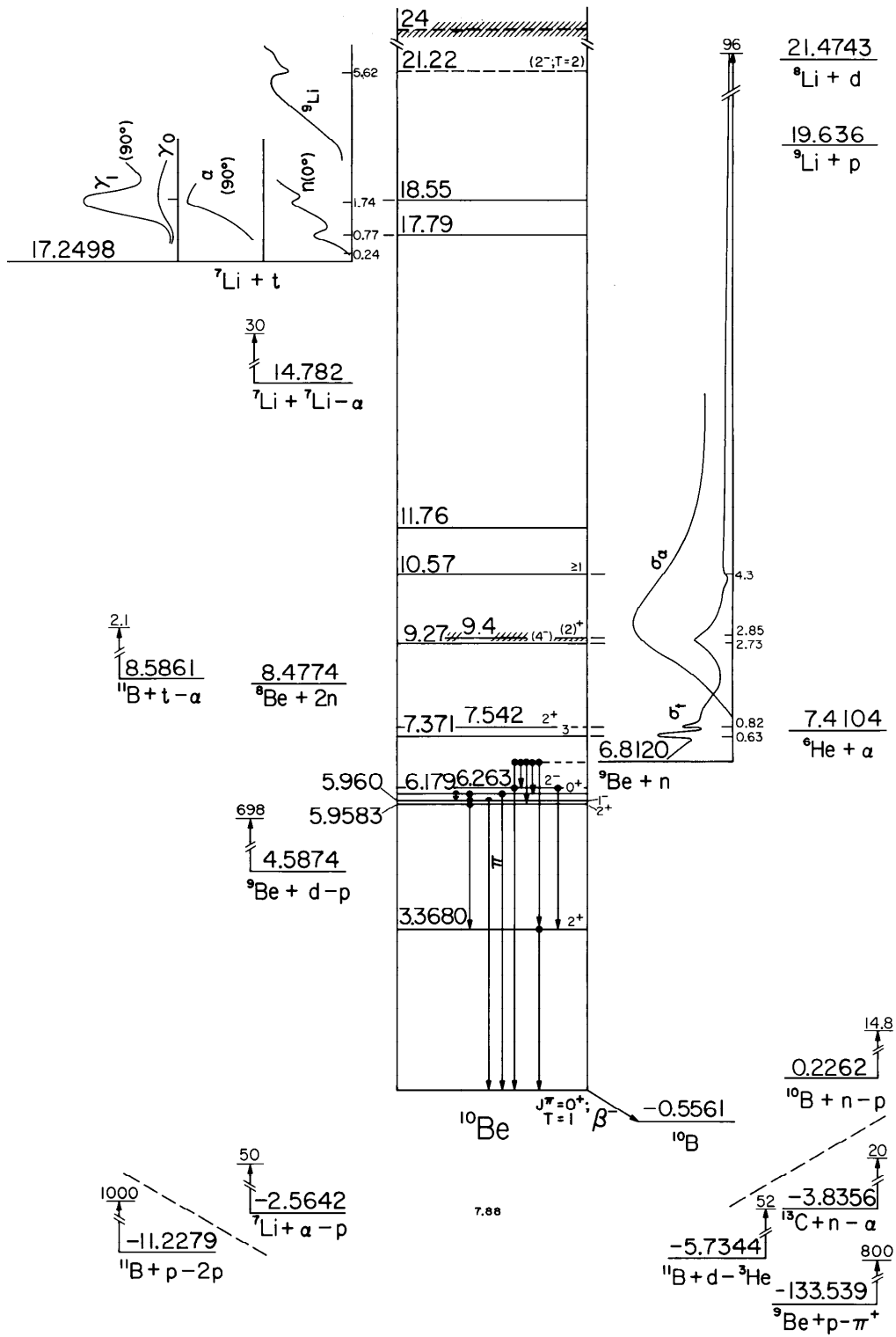

Ground-state properties of ^{10}Be : (1983ANZQ, 1984FR13, 1984NI12, 1985AN28, 1985SA32, 1985TA18, 1986WI04, 1987BL18, 1987HA30, 1987LE33, 1987SA15, 1988JO1C).

The interaction nuclear radius of ^{10}Be is 2.46 ± 0.03 fm [(1985TA18), $E = 790$ MeV/A; see also for derived nuclear matter, charge and neutron matter r.m.s. radii].

$$B(E2)\uparrow \text{ for } ^{10}\text{Be}^*(3.37) = (5.2 \pm 0.6) \times 10^{-3} e^2 \cdot \text{b}^2 [Q_0 = 0.229 \pm 0.013 \text{ b}] \text{ (1987RA01)}.$$

$$1. \ ^{10}\text{Be}(\beta^-)^{10}\text{B} \quad Q_m = 0.5561$$

The half-life of ^{10}Be is $(1.51 \pm 0.06) \times 10^6$ y (1987HO1P). $\text{Log } ft = 13.397 \pm 0.017$ (M.J. Martin, private communication). For the earlier work see (1974AJ01).

$$\begin{array}{lll} 2. \text{ (a) } ^7\text{Li}(t, \gamma)^{10}\text{Be} & Q_m = 17.2498 & \\ \text{ (b) } ^7\text{Li}(t, n)^9\text{Be} & Q_m = 10.4378 & E_b = 17.2498 \\ \text{ (c) } ^7\text{Li}(t, p)^9\text{Li} & Q_m = -2.386 & \\ \text{ (d) } ^7\text{Li}(t, t)^7\text{Li} & & \\ \text{ (e) } ^7\text{Li}(t, \alpha)^6\text{He} & Q_m = 9.839 & \end{array}$$

The yield of γ_0 and γ_1 has been studied for $E_t = 0.4$ to 1.1 MeV [$^{10}\text{Be}^*(17.79)$ is said to be involved]: see (1984AJ01). The neutron yield exhibits a weak structure at $E_t = 0.24$ MeV and broad resonances at $E_t \approx 0.77$ MeV [$\Gamma = 160 \pm 50$ keV] and 1.74 MeV: see (1966LA04) [$^{10}\text{Be}^*(17.79, 18.47)$]. The total cross section for reaction (c), the yield of neutrons (reaction (b) to $^9\text{Be}^*(14.39)$), and the yield of γ -rays from $^7\text{Li}^*(0.48)$ (reaction (d)) all show a sharp anomaly at $E_t = 5.685$ MeV: $J^\pi = 2^-$; $T = 2$ is suggested for a state at $E_x = 21.22$ MeV. The total cross section for α_0 (reaction (e)) and the all-neutrons yield do not show this structure: see (1983AB1A), (1984AJ01) and (1985DE19; theor.). An additional anomaly in the proton yield is also reported at $E_t = 8.5$ MeV [$^{10}\text{Be}^*(23.2)$][see (1987AB15)]. Differential cross sections and S -factors are reported by (1983CE1A) for $E_t = 70$ to 110 keV for $^6\text{He}^*(0, 1.80)$. The zero-energy S -factor for $^6\text{He}^*(1.80)$ is 14 ± 2.5 MeV \cdot b. The relevance to an Li-seeded tritium plasma is discussed by (1983CE1A). See also (1987AB09), (1985CA41; astrophys.) and (1986AB10; theor.).

$$3. \ ^7\text{Li}(^3\text{He}, \pi^+)^{10}\text{Be} \quad Q_m = -122.337$$

Cross sections have been measured to $^{10}\text{Be}^*(3.37, 6.2[\text{u}], 7.4[\text{u}]$ [u=unresolved]) at $E(^3\text{He}) = 235$ MeV. The ground-state group is not seen: its intensity at $\theta_{\text{lab}} = 20^\circ$ is ≤ 0.1 that to $^{10}\text{Be}^*(3.37)$ (1984BI08).

Table 10.1: Energy levels of ^{10}Be ^a

E_x (MeV \pm keV)	$J^\pi; T$	τ or $\Gamma_{\text{c.m.}}$ (keV)	Decay	Reactions
g.s.	$0^+; 1$	$\tau_{1/2} = (1.51 \pm 0.06) \times 10^6 \text{ y}$	β^-	1, 2, 4, 5, 6, 10, 11, 12, 13, 14, 15, 17, 18, 19, 20, 21, 22, 23, 24, 26
3.36803 ± 0.03	$2^+; 1$	$\tau_m = 180 \pm 17 \text{ fsec}$	γ	2, 3, 4, 5, 6, 10, 11, 12, 13, 14, 15, 16, 17, 18, 19, 20, 21, 22, 23, 24, 26
5.95839 ± 0.05	$2^+; 1$	$\tau_m < 80 \text{ fsec}$	γ	4, 6, 11, 12, 16, 18, 19, 22, 24
5.9599 ± 0.6	$1^-; 1$		γ	4, 11, 12, 18, 19, 22, 24
6.1793 ± 0.7	$0^+; 1$	$\tau_m = 1.1^{+0.4}_{-0.3} \text{ psec}$	π, γ	11, 19
6.2633 ± 5	$2^-; 1$		γ	11, 12
7.371 ± 1	$3^-; 1$	$\Gamma = 15.7 \pm 0.5 \text{ keV}$	n	5, 7, 11, 12
7.542 ± 1	$2^+; 1$	6.3 ± 0.8	n	4, 5, 7, 11, 12, 24
9.27	$(4^-); 1$	150 ± 20	n	5, 7, 11, 12
9.4	$(2^+); 1$	291 ± 20	n	5, 7, 11, 12, 18, 24
10.57 ± 30	$\geq 1; 1$		n	4, 5, 7, 11
11.76 ± 20		121 ± 10		4, 5, 11, 12, 24
17.79		110 ± 35	$\gamma, \text{ n, t}$	2, 4, 5
18.55		≈ 350	n, t	2, 4, 5
(21.22)	$(2^-; 2)$	sharp	n, p, t	2
(24)				25

^a See also Table 10.4.

Table 10.2: Neutron-capture γ -rays in ^{10}Be ^a

E_γ (keV) ^b	Transition	E_x (keV) ^b
6809.585 (33)	capt. \rightarrow g.s.	6812.038 (29)
5955.9 (5) ^a	5.96 ^c \rightarrow g.s.	5958.387 (51)
3443.374 (30)	capt. \rightarrow 3.37	
3367.415 (30)	3.37 \rightarrow g.s.	3368.029 (29)
2589.999 (60)	5.96 ^c \rightarrow 3.37	
853.605 (60)	capt. \rightarrow 5.96 ^c	

^a See also Tables 10.2 in (1974AJ01, 1979AJ01).

^b (1983KE11). 12 eV has been added in quadrature to the uncertainties. I am very grateful to T.J. Kennett for his comments. Some of the work displayed in Table 10.2 of (1984AJ01) is not shown here because it has not been published. However, those particular transitions are shown in Fig. 1 since it is clear that they have been observed although the lack of published uncertainties make their inclusion in this table inadvisable.

^c This is the 2^+ member of the doublet at $E_x = 5.96$ MeV.

$$4. \text{}^7\text{Li}(\alpha, \text{p})^{10}\text{Be} \quad Q_m = -2.5642$$

See (1987BI1C) and (1979AJ01).

$$5. \text{}^7\text{Li}(\text{}^7\text{Li}, \alpha)^{10}\text{Be} \quad Q_m = 14.782$$

See (1974AJ01).

$$6. \text{}^9\text{Be}(\text{n}, \gamma)^{10}\text{Be} \quad Q_m = 6.8120$$

The thermal capture cross section is 8.49 ± 0.34 mb (1986CO14). Reported γ -ray transitions are displayed in Table 10.2 (1983KE11). Partial cross sections involving $^{10}\text{Be}^*(0, 3.37, 5.96)$ are listed in (1987LY01). See also (1984SH1P, 1984SH1R) and (1985MU03, 1986MU1B, 1986RA1B, 1987LY01, 1988MU05; theor.).

Table 10.3: Resonances in ${}^9\text{Be}(n, n){}^9\text{Be}$ ^a

E_{res} (MeV \pm keV)	${}^{10}\text{Be}^*$ (MeV)	$\Gamma_{\text{c.m.}}$ (keV)	J^π	l	θ^2 (%) ^b
0.6220 ± 0.8	7.371	15.7 ± 0.5	3^-	2	7.5
0.8118 ± 0.7	7.542	6.3 ± 0.8	2^+	1	0.28
2.73	9.27	≈ 100	(4^-)	(2)	
(2.85)	9.4	≈ 400	(2^+)	(1)	
4.3	10.7		≥ 1		

^a For references see Table 10.3 in (1979AJ01).

^b $R = 5.6$ fm.

7. (a) ${}^9\text{Be}(n, n){}^9\text{Be}$

$$E_b = 6.8120$$

(b) ${}^9\text{Be}(n, 2n){}^8\text{Be}$

$$Q_m = -1.6654$$

The scattering amplitude (bound) $a = 7.778 \pm 0.003$ fm, $\sigma_{\text{free}} = 6.151 \pm 0.005$ b (1981MUZQ). The difference in the spin-dependent scattering lengths, $b^+ - b^-$ is $+0.24 \pm 0.07$ (1987GL06). See also (1987LY01). Total cross section measurements have been reported for $E_n = 2 \times 10^{-3}$ eV to 2.6 GeV/ c [see (1979AJ01, 1984AJ01)] and at 24 keV (1983AI01), 7 to 15 MeV (1983DA22; also reaction cross sections) and 10.96, 13.89 and 16.89 MeV (1985TE01; for n_0 and n_2).

Observed resonances are displayed in Table 10.3. Analysis of polarization and differential cross section data leads to the 3^- , 2^+ assignments for ${}^{10}\text{Be}^*(7.37, 7.55)$. Below $E_n = 0.5$ MeV the scattering cross section reflects the effect of bound 1^- and 2^- states, presumably ${}^{10}\text{Be}^*(5.960, 6.26)$. There is also indication of interference with s-wave background and with a broad $l = 1$, $J^\pi = 3^+$ state. The structure at $E_n = 2.73$ MeV is ascribed to two levels: a broad state at about 2.85 MeV with $J^\pi = 2^+$, and a narrow one, $\Gamma \approx 100$ keV, at $E_n = 2.73$ MeV with a probable assignment of $J^\pi = 4^-$. The 4^- assignment results from a study of the polarization of the n_0 group at $E_n = 2.60$ to 2.77 MeV. A rapid variation of the polarization over this interval is observed, and the data are consistent with 4^- ($l = 2$) for ${}^{10}\text{Be}^*(9.27)$. A weak dip at $E_n \approx 4.3$ MeV is ascribed to a level with $J \geq 1$. See (1974AJ01) for references. The analyzing power has been measured for $E_n = 1.6$ to 15 MeV [see (1984AJ01)] and at $E_n = 9$ to 17 MeV (1984BY03; n_0, n_2).

The non-elastic and the (n, 2n) cross sections rise rapidly to ≈ 0.6 b (≈ 0.5 b for (n, 2n)) at $E_n \approx 3.5$ MeV and then stay approximately constant to $E_n = 15$ MeV: see (1979AJ01, 1984AJ01). For total γ -ray production cross sections for $E_n = 2$ to 25 MeV, see (1986GO1L). See also (1983GO1H, 1984SH1P, 1984SH1R, 1986MU07), (1985PE06; applications) and (1986DU1G, 1987HAZS; theor.).

8. (a) ${}^9\text{Be}(n, p){}^9\text{Li}$

$$Q_m = -12.824$$

$$E_b = 6.8120$$

$$\begin{aligned} \text{(b) } {}^9\text{Be}(n, d){}^8\text{Li} & \quad Q_m = -14.662 \\ \text{(c) } {}^9\text{Be}(n, t){}^7\text{Li} & \quad Q_m = -10.438 \end{aligned}$$

Cross sections have been measured at $E_n = 14.1\text{--}14.9$ MeV for reaction (a), 16.3 to 18.7 MeV for (b) and 13.3 to 15.0 (t_1) and 22.5 MeV (reaction (c)): see (1979AJ01). A recent measurement (reaction (c)) has been reported at $E_n = 14.6$ MeV (1987ZA01). See (1983BO1C) and (1984SHIP, 1984SH1R, 1985BO1D).

$$9. {}^9\text{Be}(n, \alpha){}^6\text{He} \quad Q_m = -0.598 \quad E_b = 6.8120$$

The cross section for production of ${}^6\text{He}$ shows a smooth rise to a broad maximum of 104 ± 7 mb at 3.0 MeV, followed by a gradual decrease to 70 mb at 4.4 MeV. From $E_n = 3.9$ to 8.6 MeV, the cross section decreases smoothly from 100 mb to 32 mb. Excitation functions have been measured for α_0 and α_1 for $E_n = 12.2$ to 18.0 MeV: see (1979AJ01) for references. See also (1983SH1J) and (1984SHIP, 1984SH1R).

$$10. {}^9\text{Be}(p, \pi^+){}^{10}\text{Be} \quad Q_m = -133.539$$

Angular distributions have been studied at $E_p = 185$ to 800 MeV [see (1984AJ01)] and at $E_p = 650$ MeV (1986HO23; to ${}^{10}\text{Be}^*(0, 3.37)$). States at $E_x = 6.07 \pm 0.13, 7.39 \pm 0.13, 9.31 \pm 0.24, 11.76$ MeV have also been populated. A_y measurements involving ${}^{10}\text{Be}^*(0, 3.37)$ are reported at $E_p = 200$ to 250 MeV [see (1984AJ01)] and at 650 MeV (1986HO23).

$$11. {}^9\text{Be}(d, p){}^{10}\text{Be} \quad Q_m = 4.5874$$

Angular distributions of proton groups have been studied at many energies in the range $E_d = 0.15$ to 17.3 MeV and at 698 MeV [see (1979AJ01, 1984AJ01)], as well as at $E_d = 2.0$ to 2.8 MeV (1984DE46, 1984AN16; p_0, p_1 ; also VAP) and $E_d = 12.5$ MeV (1987VA13; p_0, p_1). At $E_d = 15$ MeV $S = 2.1, 0.23$ ($j_n = \frac{3}{2}$) and 0.12 ($j_n = \frac{1}{2}$), $\leq 1.0, 0.065$ ($j_n = \frac{5}{2}$) and 0.132 ($j_n = \frac{1}{2}$), for ${}^{10}\text{Be}^*(0, 3.37, 5.96, 6.26)$. The angular distributions show $l_n = 1$ transfer for ${}^{10}\text{Be}^*(0, 3.37, 5.958, 7.54)$, $l_n = 0$ transfer for ${}^{10}\text{Be}^*(5.960, 6.26)$, $l_n = 2$ transfer for ${}^{10}\text{Be}^*(7.37)$. ${}^{10}\text{Be}^*(6.18, 9.27, 9.4)$ are also populated, as are two states at $E_x = 10.57 \pm 0.03$ and 11.76 ± 0.02 MeV. ${}^{10}\text{Be}^*(9.27, 9.4, 11.76)$ have $\Gamma_{\text{c.m.}} = 150 \pm 20, 291 \pm 20$ and 121 ± 10 keV. See (1979AJ01) for references.

Attempts to understand the γ -decay of ${}^{10}\text{Be}^*(5.96)$ and its population in ${}^9\text{Be}(n, \gamma){}^{10}\text{Be}$ led to the discovery that it consisted of two states separated by 1.6 ± 0.5 keV. The lower of the two has $J^\pi = 2^+$ and decays primarily by a cascade transition via ${}^{10}\text{Be}^*(3.37)$ [it is the state fed directly in the ${}^9\text{Be}(n, \gamma)$ decay]; the higher state has $J^\pi = 1^-$ and goes mainly by a crossover to

Table 10.4: Radiative transitions in ${}^9\text{Be}(d, p){}^{10}\text{Be}$ ^a

E_x (keV)	Transition	ΔJ^π	Mtpl.	Branch (%)	τ_m (psec)	Γ_γ (meV)
3368.0 ± 0.2	$3.37 \rightarrow \text{g.s.}$	$2^+ \rightarrow 0^+$	E2	100	0.189 ± 0.020	3.48 ± 0.37
					0.160 ± 0.030	4.11 ± 0.78
5958.3 ± 0.3	$5.96 \rightarrow 3.37$	$2^+ \rightarrow 2^+$	M1	> 90	< 0.08	
	$5.96 \rightarrow \text{g.s.}$	$2^+ \rightarrow 0^+$	E2	< 10		
5959.9 ± 0.6	$5.96 \rightarrow \text{g.s.}$	$1^- \rightarrow 0^+$	E1	83_{-6}^{+10}		
	$5.96 \rightarrow 3.37$	$1^- \rightarrow 2^+$	E1	17_{-10}^{+6}		
6179.3 ± 0.7	$6.18 \rightarrow 5.96$	$0^+ \rightarrow 1^-$	E1	24 ± 2	$1.1_{-0.3}^{+0.4}$	0.14 ± 0.05
	$6.18 \rightarrow 3.37$	$0^+ \rightarrow 2^+$	E2	76 ± 2		0.46 ± 0.28
	$6.18 \rightarrow \text{g.s.}$	$0^+ \rightarrow 0^+$	E0			
6263.3 ± 5	$6.26 \rightarrow 5.96$	1^-	M1	} ≤ 1		
		$2^- \rightarrow$				
	2^+	E1				
	$6.26 \rightarrow 3.37$	$2^- \rightarrow 2^+$	E1			
	$6.26 \rightarrow \text{g.s.}$	$2^- \rightarrow 0^+$	M2	1 ± 1		

^a See Table 10.4 in (1979AJ01) for references. However, note that there are several typographical errors in the ${}^{10}\text{Be}^*(6.18)$ decay.

${}^{10}\text{Be}(\text{g.s.})$. Angular correlations measured with the γ -ray detector located normal to the reaction plane (\equiv angular distributions) lead to l_n values consistent with the assignments of 2^+ and 1^- for ${}^{10}\text{Be}^*(5.9584, 5.9599)$ obtained from the character of the γ -decay. ${}^{10}\text{Be}^*(6.18)$ decays primarily to ${}^{10}\text{Be}^*(3.37)$: $E_\gamma = 219.4 \pm 0.3$ keV for the $6.18 \rightarrow 5.96$ transition. See Table 10.4 for a listing of the information on radiative transitions obtained in this reaction and lifetime measurements. For (p, γ) correlations through ${}^{10}\text{Be}^*(3.37)$ see (1987VA13) and references in (1974AJ01). For polarization measurements see ${}^{11}\text{B}$ in (1990AJ01).

$$12. {}^9\text{Be}(\alpha, {}^3\text{He}){}^{10}\text{Be} \quad Q_m = -13.7658$$

Angular distributions have been studied at $E_\alpha = 65$ MeV to ${}^{10}\text{Be}^*(0, 3.37, 5.96, 6.26, 7.37, 7.54, 9.33, 11.88)$. DWBA analyses of these lead to spectroscopic factors which are in poor agreement with those reported in other reactions: see (1984AJ01).

$$13. (a) {}^9\text{Be}({}^7\text{Li}, {}^6\text{Li}){}^{10}\text{Be} \quad Q_m = -0.438$$

$$(b) {}^9\text{Be}({}^9\text{Be}, {}^8\text{Be}){}^{10}\text{Be} \quad Q_m = 5.1466$$

Angular distributions have been measured at $E({}^7\text{Li}) = 34$ MeV (reaction (a)) to ${}^{10}\text{Be}^*(0, 3.4)$: $S = 2.07$ and 0.42 ($p_{1/2}$), 0.38 ($p_{3/2}$). See (1979AJ01). At $E({}^9\text{Be}) = 20$ MeV an angular distribution involving ${}^8\text{Be}_{g.s.} + {}^{10}\text{Be}_{g.s.}$ has been measured: transitions to excited states of ${}^{10}\text{Be}$ are very weak (1985JA09).

$$14. (a) {}^{10}\text{Be}(p, p){}^{10}\text{Be}$$

$$(b) {}^{10}\text{Be}(d, d){}^{10}\text{Be}$$

Angular distributions of the p_0 and p_1 groups have been measured at $E_p = 12.0$ to 16.0 MeV. The elastically scattered deuterons have been studied at $E_d = 12.0$ and 15.0 MeV: see (1974AJ01).

$$15. (a) {}^{10}\text{B}(\gamma, \pi^+){}^{10}\text{Be} \quad Q_m = -140.125$$

$$(b) {}^{10}\text{B}(e, e'\pi^+){}^{10}\text{Be} \quad Q_m = -140.125$$

Differential cross sections have been measured to ${}^{10}\text{Be}^*(0, 3.37)$ at $E_\gamma = 230$ to 340 MeV [see (1984AJ01)] and at $E_e = 185$ MeV (1986YA07) and 200 MeV (1984BLZY). See also (1984AJ01).

$$16. {}^{10}\text{B}(\mu^-, \nu){}^{10}\text{Be} \quad Q_m = 105.1031$$

Partial capture rates leading to the 2^+ states ${}^{10}\text{Be}^*(3.37, 5.96)$ have been reported: see (1984AJ01).

$$17. {}^{10}\text{B}(\pi^-, \gamma){}^{10}\text{Be} \quad Q_m = 139.012$$

The photon spectrum from stopped pions is dominated by peaks corresponding to ${}^{10}\text{Be}^*(0, 3.4, 6.0, 7.5, 9.4)$, and branching ratios have been obtained. Those to ${}^{10}\text{Be}^*(0, 3.4)$ are $(2.02 \pm 0.17)\%$ and $(4.65 \pm 0.30)\%$, respectively [absolute branching ratio per stopped pion] (1986PE05). See (1979AJ01) for the earlier work.

$$18. (a) {}^{10}\text{B}(n, p){}^{10}\text{Be} \quad Q_m = 0.2262$$

$$(b) {}^{10}\text{B}(d, 2p){}^{10}\text{Be} \quad Q_m = -1.9983$$

Angular distributions [reaction (b)] are reported at $E_d = 55$ MeV to $^{10}\text{Be}^*(0, 3.37, 5.96, 9.4)$: see (1984AJ01). See also (1987KW01; theor.). For reaction (a) see (1974AJ01) and (1987LA16) in ^{11}B (1990AJ01).



^{11}Li populates several states of ^{10}Be , via delayed neutron emission. Gamma rays have been observed for the transitions $6.18 \rightarrow 5.96$, $6.18 \rightarrow 3.37$, 5.96 (unres.) $\rightarrow 3.37$ and $3.37 \rightarrow \text{g.s.}$ with $I_\gamma = (0.95 \pm 0.35)$, (1.65 ± 0.70) , (3.5 ± 1.0) and $(21 \pm 6)\%$, respectively: see Table 11.2 in (1985AJ01).



See (1984AL22) and ^{11}B in (1990AJ01). See also (1979AJ01).



Structure is observed in the summed proton spectrum corresponding to $Q = -10.9 \pm 0.35$, -14.7 ± 0.4 , -21.1 ± 0.4 , -35 ± 1 MeV: see (1974AJ01). See also (1985BE30, 1985DO16; prelim.).



Angular distributions have been measured at $E_d = 11.8$ and 22 MeV to $^{10}\text{Be}_{\text{g.s.}}$ [see (1974AJ01)] and at 52 MeV to $^{10}\text{Be}^*(0, 3.37, 5.96, 9.60)$: $S = 0.65, 2.03, 0.13, 1.19$ (normalized to the theoretical value for the ground state); $\pi = +$ for $^{10}\text{Be}^*(9.6)$: see (1979AJ01).



See (1985PO02).



At $E(^6\text{Li}) = 80$ MeV, $^{10}\text{Be}^*(0, 3.37, 5.96, 7.54, (9.4), 11.8)$ are populated and the angular distribution to $^{10}\text{Be}_{\text{g.s.}}$ has been measured: see (1979AJ01). See also (1982AL08, 1983AL20, 1985AL1G).

$$25. \ ^{13}\text{C}(\text{p}, \text{d}2\text{p})^{10}\text{Be} \quad Q_{\text{m}} = -29.9069$$

See (1987GIZZ) and ^{12}C in (1990AJ01).

$$26. \ ^{14}\text{C}(^{14}\text{C}, ^{18}\text{O})^{10}\text{Be} \quad Q_{\text{m}} = -5.785$$

See (1985KO04).

¹⁰B
(Figs. 2 and 4)

GENERAL: See also (1984AJ01).

Shell and deformed models: (1983VA31, 1984VA06, 1984ZW1A, 1987KI1C, 1988OR1C, 1988WO04).

Cluster and α -particle models: (1983SH38, 1984NI12, 1985KW02).

Special states: (1983BI1C, 1983FE07, 1983VA31, 1984NI12, 1984VA06, 1984ZW1A, 1985GO1A, 1985HA18, 1985HA1J, 1986BA1X, 1986XU02, 1987AB1H, 1987BA2J, 1987KI1C, 1988KW02).

Electromagnetic transitions and giant resonances: (1983GM1A, 1984NI12, 1985GO1A, 1987BA2J, 1987KI1C).

Astrophysical questions: (1982AU1A, 1982CA1A, 1984TR1C, 1985CA41, 1985WA1K, 1987AR1C, 1987AU1A, 1987RO25, 1988KR1G, 1988RE1B).

Complex reactions involving ¹⁰B: (1983EN04, 1983GU1A, 1983NA08, 1983OL1A, 1984GR08, 1984HI1A, 1984HO23, 1984RE14, 1984TE1A, 1985KAZQ, 1985LI1B, 1985MO08, 1985WI18, 1986AV1A, 1986CA30, 1986HA1B, 1986MA19, 1986ME06, 1986MO13, 1986SA30, 1986SH1F, 1986UT01, 1986XU02, 1986XU1B, 1987AK1A, 1987AR19, 1987BA38, 1987BA39, 1987BU07, 1987DE37, 1987FE1A, 1987GE1B, 1987HE1H, 1987HI05, 1987JA06, 1987KO15, 1987LY04, 1987MU03, 1987NA01, 1987PO23, 1987RO10, 1987ST01, 1987TR05, 1987WA09, 1987YA16, 1988BL09, 1988CA06, 1988KI05, 1988KR11, 1988RU01, 1988SA19, 1988SI01, 1988TS03).

Applications: (1983AM1A, 1983KU1C, 1985KO47, 1986EN1A, 1986WE1E).

Muon and neutrino capture and reactions: (1983GM1A, 1985MI1D, 1987KU23, 1987SU06).

Pion and kaon capture and reactions (See also reactions 23 and 48.): (1982BE1D, 1983AN1F, 1983BA71, 1983FE07, 1983GE12, 1983GE13, 1983GE1C, 1983GM1A, 1983MA40, 1983ZIZZ, 1984BA1U, 1984CO1D, 1984ER1B, 1984KA1C, 1984MA1F, 1985IM1A, 1985RO17, 1985TU1B, 1985ZI04, 1986BE1P, 1986GA1F, 1986GA1H, 1986MA1C, 1986PE05, 1986RA16, 1986RO03, 1988AB05, 1987LE1E, 1987NA04, 1987SI18, 1988GIZU, 1988GIZT, 1988RIZZ).

Hypernuclei: (1982KA1D, 1983FE07, 1983SH38, 1983SH1E, 1984BO1H, 1984CH1H, 1984ER1A, 1984MA1F, 1984MI1C, 1984MI1E, 1984SH1J, 1984ZH1B, 1985AH1A, 1985DEZY, 1985GU1J, 1986AN1R, 1986CH1P, 1986DA1B, 1986GA1H, 1986MA1C, 1986MA1W, 1987BO1L, 1987MI38, 1987PO1H).

Other topics: (1983BI1C, 1985AN28, 1986IS04, 1986YA1F, 1987BA2J, 1988AJ1B, 1988KW02, 1988OR1C).

Ground-state properties of ¹⁰B: (1983ANZQ, 1983VA31, 1984BR25, 1984MIZM, 1984NI12, 1984VA06, 1985AN28, 1985GO1A, 1985HA18, 1985ZI05, 1986DO1E, 1986GL1A, 1986RO03, 1987KI1C, 1987LE33, 1988VA03, 1988WO04).

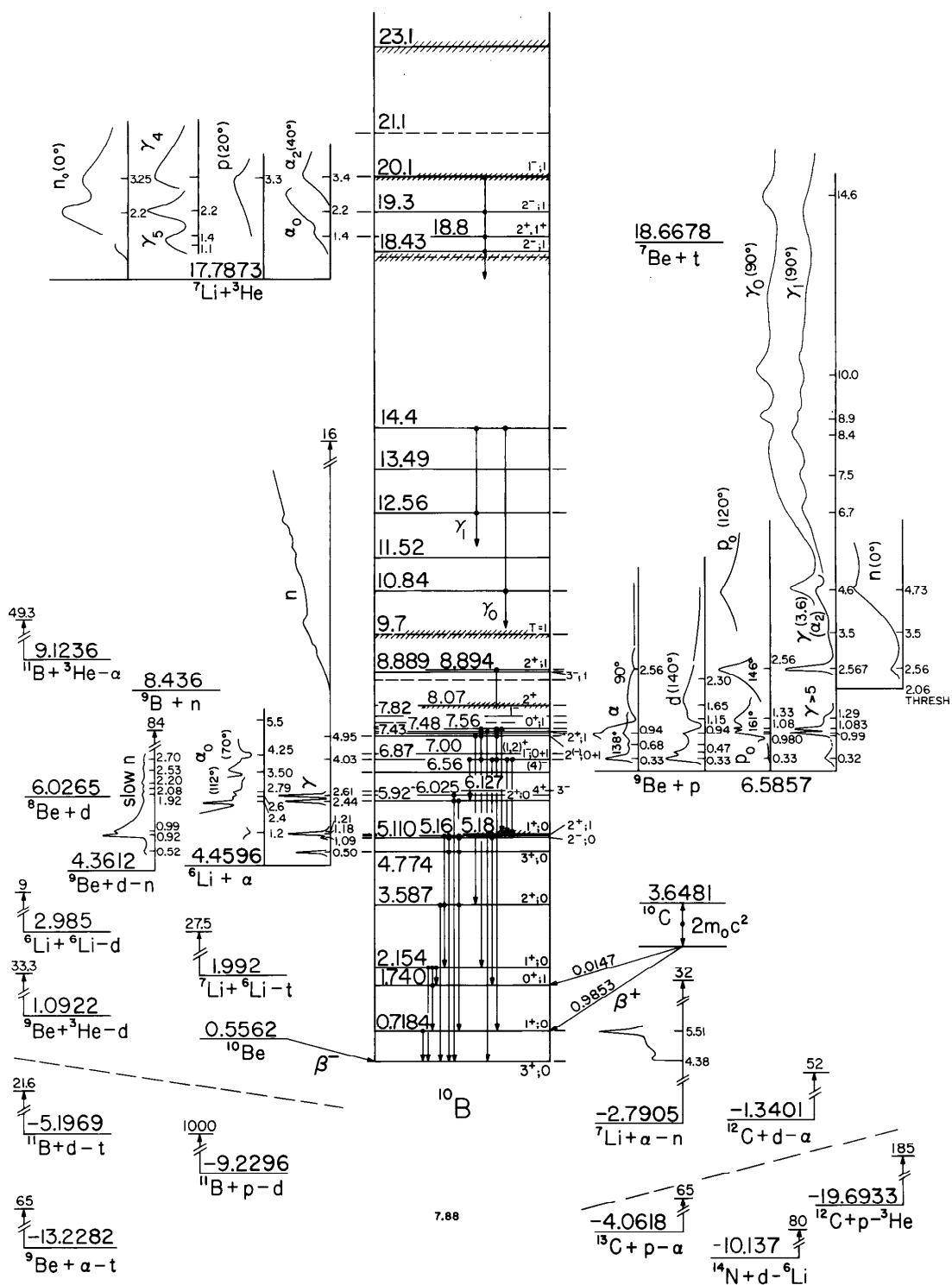

Fig. 2: Energy levels of ^{10}B . For notation see Fig. 1.

Table 10.5: Energy levels of ^{10}B ^a

E_x (MeV \pm keV)	$J^\pi; T$	τ_m or $\Gamma_{c.m.}$ (keV)	Decay	Reactions
g.s.	$3^+; 0$	stable		1, 4, 5, 10, 11, 16, 17, 18, 19, 20, 22, 23, 24, 25, 26, 27, 28, 29, 30, 31, 32, 33, 34, 35, 36, 37, 38, 39, 40, 42, 43, 44, 45, 49, 50, 51, 52, 53, 54, 56, 57
0.71835 ± 0.04	$1^+; 0$	$\tau_m = 1.020 \pm 0.005$ nsec $g = +0.63 \pm 0.12$	γ	1, 4, 5, 10, 11, 16, 17, 18, 19, 21, 24, 25, 26, 28, 29, 34, 40, 42, 43, 44, 45, 48, 49, 50, 51, 53, 56
1.74015 ± 0.17	$0^+; 1$	7 ± 3 fsec	γ	1, 4, 10, 11, 16, 17, 18, 19, 23, 24, 25, 28, 40, 41, 42, 43, 44, 45, 49, 50, 54
2.1543 ± 0.5	$1^+; 0$	2.13 ± 0.20 psec	γ	1, 4, 11, 16, 17, 18, 19, 24, 25, 26, 28, 29, 34, 42, 43, 44, 45, 48, 49, 50, 51, 52, 53
3.5871 ± 0.5	$2^+; 0$	153 ± 12 fsec	γ	1, 4, 5, 11, 16, 17, 18, 24, 25, 26, 28, 29, 41, 42, 44, 49, 50, 51, 53, 56
4.7740 ± 0.5	$3^+; 0$	$\Gamma = 8.4 \pm 1.8$ eV	γ, α	1, 4, 5, 16, 17, 18, 24, 25, 26, 29, 44, 49, 50, 51, 56
5.1103 ± 0.6	$2^-; 0$	0.98 ± 0.07 keV	γ, α	1, 11, 16, 17, 25, 29, 44, 50
5.1639 ± 0.6	$2^+; 1$	$\tau_m < 6$ fsec	γ, α	1, 11, 16, 17, 23, 25, 26, 41, 44, 49
5.180 ± 10	$1^+; 0$	$\Gamma = 110 \pm 10$	γ, α	1, 3, 11, 16, 17, 26, 29, 44
5.9195 ± 0.6	$2^+; 0$	6 ± 1	γ, α	1, 3, 11, 16, 17, 18, 25, 26, 28, 29, 44, 49, 50, 51

Table 10.5: Energy levels of ^{10}B ^a (continued)

E_x (MeV \pm keV)	$J^\pi; T$	τ_m or $\Gamma_{c.m.}$ (keV)	Decay	Reactions
6.0250 \pm 0.6	4 ⁺	0.05 \pm 0.03	γ, α	1, 3, 16, 17, 18, 23, 24, 25, 26, 28, 29, 42, 44, 50, 51, 54, 56
6.1272 \pm 0.7	3 ⁻	2.36 \pm 0.03	α	3, 16, 17, 18, 25, 26, 28, 42, 44, 50
6.560 \pm 1.9	(4) ⁻	25.1 \pm 1.1	α	3, 16, 17, 18, 25, 26, 28, 29, 42, 44, 49, 50
6.873 \pm 5	1 ⁻ ; 0 + 1	120 \pm 5	γ, p, d, α	1, 11, 13, 15, 16
7.002 \pm 6	(1, 2) ⁺ ; (0)	100 \pm 10	p, d, α	3, 15, 16, 18, 25, 26, 28, 44, 50, 56
7.430 \pm 10	2 ⁽⁻⁾ ; 0 + 1	100 \pm 10	γ, p, d, α	1, 11, 15
7.467 \pm 10	1 ⁺	65 \pm 10	p	13, 44
7.478 \pm 2	2 ⁺ ; 1	74 \pm 4	γ, p	11, 13, 23, 44
7.5599 \pm 0.6	0 ⁺ ; 1	2.65 \pm 0.18	γ, p	11, 13, 16, 44
(7.67 \pm 30)	(1 ⁺ ; 0)	250 \pm 20	p, d	13, 15
7.819 \pm 20	1 ⁻	260 \pm 30	p	13, 16, 18, 44
8.07	2 ⁺	800 \pm 200	γ, p, d	15, 16, 23
(8.7)	(1 ⁺ , 2 ⁺)	(\approx 200)	p	13, 15, 56
8.889 \pm 6	3 ⁻ ; 1	84 \pm 7	γ, n, p, α	12, 13, 15, 18, 23, 49
8.894 \pm 2	2 ⁺ ; 1	40 \pm 1	γ, p, α	11, 13, 15, 18, 23, 49
(9.7)	($T = 1$)	(\approx 700)	n, p, α	12, 15
10.84 \pm 10	(2 ⁺ , 3 ⁺ , 4 ⁺)	300 \pm 100	γ, n, p	11, 12, 13, 23, 44
11.52 \pm 35		500 \pm 100	(γ)	23, 42, 44
12.56 \pm 30	(0 ⁺ , 1 ⁺ , 2 ⁺)	100 \pm 30	γ, p	11, 23, 44
13.49 \pm 5	(0 ⁺ , 1 ⁺ , 2 ⁺)	300 \pm 50	γ, p	11, 23, 44
14.4 \pm 100		800 \pm 200	γ, p, α	3, 11, 42, 44
(18.2 \pm 200)		(1500 \pm 300)		44
18.43	2 ⁻ ; 1	340	$\gamma, ^3\text{He}$	5, 7
18.80	2 ⁺ , 1 ⁺	< 600	$\gamma, ^3\text{He}, \alpha$	5, 9
19.29	2 ⁻ ; 1	190 \pm 20	$\gamma, n, p, ^3\text{He}, \alpha$	5, 6, 7, 9
20.1 \pm 100	1 ⁻ ; 1	broad	$\gamma, n, p, t, ^3\text{He}, \alpha$	5, 6, 7, 8, 9, 22
(21.1)			$\gamma, ^3\text{He}$	5

Table 10.5: Energy levels of ^{10}B ^a (continued)

E_x (MeV \pm keV)	$J^\pi; T$	τ_m or $\Gamma_{c.m.}$ (keV)	Decay	Reactions
23.1 ± 100		broad	γ, n	22

^a See also Tables 10.6, 10.7 and 10.11.

$$\mu = +1.80065 \pm 0.00001 \text{ nm: see (1978LEZA)}$$

$$Q = +84.72 \pm 0.56 \text{ mb: see (1978LEZA).}$$

Mass of ^{10}B : (1988WA18) have re-evaluated the evidence on the mass of ^{10}B : the mass excess is 12050.99 ± 0.27 keV. This readjustment includes the value obtained by (1984EL05): $12937.32 \pm 0.57 \mu\text{u}$ [mass spectrometer]. I am indebted to A.H. Wapstra for his comments.

Isotopic abundance: $(19.9 \pm 0.2)\%$ (1984DE53).

$$^{10}\text{B}^*(0.72): \mu = +0.63 \pm 0.12 \text{ nm: see (1978LEZA).}$$

$$B(E2)_{\downarrow} = 4.18 \pm 0.02 e^2 \cdot \text{fm}^4 \text{ (1983VE03).}$$

$$1. \text{ } ^6\text{Li}(\alpha, \gamma)^{10}\text{B} \quad Q_m = 4.4596$$

Observed resonances are displayed in Table 10.8. For a discussion of isovector parity mixing between $^{10}\text{B}^*(5.16, 5.11)$ [2^+ ; $T = 1$ and 2^- ; $T = 0$] see (1984NA07). For a preliminary report involving a target of laser-polarized ^6Li atoms see (1987MU13). See also (1984YA1A, 1985CA41; astrophys.).

$$2. \text{ (a) } ^6\text{Li}(\alpha, n)^9\text{B} \quad Q_m = -3.977 \quad E_b = 4.4596$$

$$\text{ (b) } ^6\text{Li}(\alpha, p)^9\text{Be} \quad Q_m = -2.1261$$

$$\text{ (c) } ^6\text{Li}(\alpha, d)^8\text{Be} \quad Q_m = -1.5669$$

The excitation functions for neutrons [from threshold to $E_\alpha = 15.5$ MeV] and for deuterons [$E_\alpha = 9.5$ to 25 MeV; d_0, d_1 over most of range] do not show resonance structure: see (1974AJ01, 1979AJ01). See also (1985GU1J; theor.).

$$3. \text{ (a) } ^6\text{Li}(\alpha, \alpha)^6\text{Li} \quad E_b = 4.4596$$

$$\text{ (b) } ^6\text{Li}(\alpha, 2\alpha)^2\text{H} \quad Q_m = -1.4750$$

Table 10.6: Electromagnetic transitions in ^{10}B ^a

Initial state	$J^\pi; T$	Γ_γ (total) (eV)	Branching ratios (%) to final states at:					Γ_γ/Γ
			g.s. 3 ⁺ ; 0	0.72 1 ⁺ ; 0	1.74 0 ⁺ ; 1	2.15 1 ⁺ ; 0	3.59 2 ⁺ ; 0	
0.72	1 ⁺ ; 0	6.5×10^{-7}	100					
1.74	0 ⁺ ; 1	0.09 ± 0.04 ^b	< 0.2	100				
2.15	1 ⁺ ; 0	$(3.1 \pm 0.3) \times 10^{-4}$	21.1 ± 1.6	27.3 ± 0.9	51.6 ± 1.6			
3.59	2 ⁺ ; 0	$(4.31 \pm 0.34) \times 10^{-3}$	19 ± 3	67 ± 3	< 0.3	14 ± 2		
4.77	3 ⁺ ; 0	0.020 ± 0.004	0.5 ± 0.1	> 99				$(2.3 \pm 0.3) \times 10^{-3}$
5.11	2 ⁻ ; 0		64 ± 7	31 ± 7	5 ± 5			
5.16	2 ⁺ ; 1	1.5 ± 0.1 ^c	4.4 ± 0.4	22.4 ± 0.6	0.7 ± 0.2	64.8 ± 0.9	7.7 ± 0.3	0.87 ± 0.04
5.18	1 ⁺ ; 0	0.06 ± 0.03			≈ 100			
5.92	2 ⁺ ; 0	0.15 ± 0.04	82 ± 5	18 ± 5				≤ 0.009
6.03	4 ⁺	0.11 ± 0.02	≈ 100	^d				≤ 0.009
6.13	3 ⁻	≤ 21						≤ 0.009
^e								

^a For references see Table 10.6 in (1979AJ01).

^b From Table 10.7.

^c See also Table 10.8 here. Branching ratios and Γ_γ/Γ from (1979KE08). The mixing ratios $\delta = 0.12 \pm 0.05, 0.03 \pm 0.03, 0.02 \pm 0.03$ and 0.00 ± 0.02 for the transitions to $^{10}\text{B}^*(0, 0.72, 2.15, 3.59)$, respectively (1979KE08).

^d Other branches < 3%.

^e For γ -decay of higher ^{10}B states see Tables 10.8, 10.10 and 10.11. See also Table 10.15.

Excitation functions of α_0 and α_1 have been reported for $E_\alpha \leq 18.0$ MeV and 9.5 to 12.5 MeV, respectively: see (1974AJ01). Reported anomalies are displayed in Table 10.9. Elastic scattering and VAP measurements are reported for $E(^6\vec{Li}) = 15.1$ to 22.7 MeV [see (1984AJ01)] and at $E(^6\vec{Li}) = 19.8$ MeV (1986CAZT; also TAP; prelim.). Small anomalies have been reported in reaction (b) corresponding to $^{10}\text{B}^*(8.67, 9.65, 10.32, 11.65)$: see (1984AJ01). See, however, Table 10.5. See also ^6Li , (1987BU27), (1986ST1E; applications) and (1986GA1F, 1986YA15, 1988LE06: theor.).

4. $^6\text{Li}(^6\text{Li}, d)^{10}\text{B}$ $Q_m = 2.985$

Angular distributions of deuteron groups have been determined at $E(^6\text{Li}) = 2.4$ to 9.0 MeV (d_0, d_1, d_3) and 7.35 and 9.0 MeV (d_4, d_5). The d_2 group is also observed but its intensity is weak: see (1974AJ01) and ^{12}C in (1980AJ01).

5. $^7\text{Li}(^3\text{He}, \gamma)^{10}\text{B}$ $Q_m = 17.7873$

Table 10.7: Lifetime of ^{10}B states

$^{10}\text{B}^*$ (MeV)	τ_m	Reactions	Refs.
0.72	1.020 ± 0.005 nsec	$^{10}\text{B}(p, p')$	(1983VE03) ^a
1.74	7 ± 3 fsec	$^6\text{Li}(\alpha, \gamma)$	(1979KE08)
2.15	2.30 ± 0.26 psec	mean	(1979AJ01) ^b
	1.9 ± 0.3 psec	$^6\text{Li}(\alpha, \gamma)$	(1979KE08)
3.59	2.13 ± 0.20 psec	mean	all values
	153 ± 13 fsec	mean	(1979AJ01)
	150 ± 30 fsec	$^6\text{Li}(\alpha, \gamma)$	(1979KE08)
5.16	153 ± 12 fsec	mean	all values
	< 6 fsec	$^6\text{Li}(\alpha, \gamma)$	(1979KE08)

^a See also Table 10.20 of (1966LA04).

^b Table 10.9 in (1979AJ01).

Table 10.8: Levels of ^{10}B from $^6\text{Li}(\alpha, \gamma)^{10}\text{B}$ ^a

E_{res} (keV)	E_x (MeV \pm keV)	$J^\pi; T$	Γ_{lab} (keV)	Decay to E_t	Branch (%)	$\omega\gamma$ (eV)	Γ_γ (eV)
500 \pm 25	4.760	3 ⁺ ; 0	$(1.4 \pm 0.3) \times 10^{-2}$	0	0.5 \pm 0.1	$(4.1 \pm 0.4) \times 10^{-2}$ ^c	0.018 \pm 0.002 ^c
				0.72	> 99		
1085	5.112	2 ⁻ ; 0	1.63 \pm 0.11 ^b	0	64 \pm 7	0.059 \pm 0.012 ^d	
				0.72	31 \pm 7	0.028 \pm 0.008	
				1.74	5 \pm 5	0.005 \pm 0.005	
1175 ^e	5.166	2 ⁺ ; 1	$(2.8 \pm 0.3) \times 10^{-3}$	0	4.4 \pm 0.4	0.018 \pm 0.002	0.068 \pm 0.007
				0.72	22.4 \pm 0.6	0.090 \pm 0.008	0.33 \pm 0.03
				1.74	0.7 \pm 0.2	$(2.8 \pm 0.8) \times 10^{-3}$	0.010 \pm 0.003
				2.15	64.8 \pm 0.9	0.259 \pm 0.024	0.942 \pm 0.090
				3.59	7.7 \pm 0.3	0.031 \pm 0.004	0.114 \pm 0.015
1210 \pm 35	5.186	1 ⁺ ; 0	340 \pm 50	1.74	\approx 100		0.06 \pm 0.03
				2435	5.922	2 ⁺	10 \pm 1
2605 ^f	6.024	4 ⁺	0.08 \pm 0.05	0.72	18 \pm 5	0.04 \pm 0.01	0.02 \pm 0.01
				1.74		< 0.02	
				0	\approx 100	0.34 \pm 0.05	0.11 \pm 0.02
4019 ^g	6.873 \pm 5	1 ⁻ ; 0 + 1	200 \pm 10	0.72		< 0.02	
				0	6 \pm 2		
				0.72	21 \pm 4		
				1.74	59 \pm 3		
4964 ^h	7.440 \pm 20	2 ⁽⁻⁾ ; 0 + 1	150 \pm 15	2.15	14 \pm 4		
				^h			

^a For earlier references see Table 10.7 in (1979AJ01).

^b $\Gamma_\alpha = \Gamma_{\text{c.m.}} = 0.98 \pm 0.07$ keV (1984NA07).

^c (1985NE05). $\Gamma_\gamma/\Gamma = (2.3 \pm 0.3) \times 10^{-3}$; $\Gamma_\alpha = 8.4 \pm 1.8$ eV (E. K. Warburton and D. E. Alburger, private communication).

^d Absolute error only.

^e Branching ratios of (1979KE08); $\omega_{\gamma\text{c.m.}} = 0.40 \pm 0.04$ eV (1979SP01). Therefore $\Gamma_\alpha\Gamma_\gamma/\Gamma_{\text{tot}} = 0.24 \pm 0.02$ eV and since $\Gamma_\gamma/\Gamma_{\text{tot}} = 0.87 \pm 0.04$, $\Gamma_\alpha = 0.28 \pm 0.03$ eV (1984NA07).

^f Values of ω_γ (1966FO05) have been multiplied by 0.6 to convert them to the c.m. system.

^g Branching ratios calculated from 0° relative intensities; $\Gamma_\alpha/\Gamma_p = 1.25 \pm 0.12$.

^h At 0° the branches to $^{10}\text{B}^*(0, 0.72)$ are equally strong ($(50 \pm 12)\%$).

Table 10.9: ^{10}B levels from $^6\text{Li}(\alpha, \alpha)^6\text{Li}$ ^a

E_α (MeV \pm keV)	E_x (MeV)	Γ_{lab} (keV)	$J^\pi; T$
1.210 ± 30	5.19	175	$1^+; 0$
2.440 ^b	5.92	≈ 30	$2^+; 0$
2.6060 ± 1.5	6.024	0.09 ± 0.04	4^+
2.7855 ± 1.5 ^c	6.132	3.93 ± 0.05	3^-
3.4985 ± 1.6 ^d	6.560	41.8 ± 1.9	$4^-, 2^-$
4.250 ± 15 ^d	7.011	183 ± 25	$(2)^+; (0)$
16.000	14.1	broad	

^a For references see Tables 10.8 in (1979AJ01) and 10.9 in (1984AJ01).

^b $\Gamma_\alpha = 9.7 \pm 0.1$ keV.

^c $\Gamma_\alpha = 2.45 \pm 0.12$ keV and $\Gamma_d = 0.08 \pm 0.05$ keV.

^d There is evidence of broad structure near these states.

Capture γ -rays have been observed for $E(^3\text{He}) = 0.8$ to 6.0 MeV. The γ_0 and γ_5 yields [to $^{10}\text{B}^*(0, 4.77)$] show resonances at $E(^3\text{He}) = 1.1$ and 2.2 MeV [$E_{\text{res}} = 0.92$ and 2.1 MeV], the γ_1 and γ_4 yields [to $^{10}\text{B}^*(0.72, 3.59)$] at 1.4 MeV and the γ_4 yield at 3.4 MeV: see Table 10.10 in (1979AJ01). Both the 1.1 and 2.2 MeV resonances [$^{10}\text{B}^*(18.4, 19.3)$] appear to result from s-wave capture; the subsequent decay is to two 3^+ states [$^{10}\text{B}^*(0, 4.77)$]. Therefore the most likely assignment is $2^-, T = 1$ for both [there appears to be no decay of these states via α_2 to $^6\text{Li}^*(3.56)$ which has $J^\pi = 0^+, T = 1$: see reaction 9]. The assignment for $^{10}\text{B}^*(18.8)$ [1.4 MeV resonance] is 1^+ or 2^+ but there appears to be α_2 decay and therefore $J^\pi = 2^+$. $^{10}\text{B}^*(20.2)$ [3.4 MeV resonance] has an isotropic angular distribution of γ_4 and therefore $J^\pi = 0^+, 1^-, 2^-$. The γ_2 group resonates at this energy which eliminates 2^- , and 0^+ is eliminated on the basis of the strength of the transition which is too large for E2. See (1974AJ01) for references.

6. $^7\text{Li}(^3\text{He}, n)^9\text{B}$

$$Q_m = 9.351$$

$$E_b = 17.7873$$

The excitation curve is smooth up to $E(^3\text{He}) = 1.8$ MeV and the n_0 yield shows resonance behavior at $E(^3\text{He}) = 2.2$ and 3.25 MeV, $\Gamma_{\text{lab}} = 270 \pm 30$ and 500 ± 100 keV. No other resonances are observed up to $E(^3\text{He}) = 5.5$ MeV. See Table 10.10 in (1979AJ01), (1986AB10; theor.) and (1974AJ01).

7. $^7\text{Li}(^3\text{He}, p)^9\text{Be}$

$$Q_m = 11.2016$$

$$E_b = 17.7873$$

Table 10.10: Resonances in ${}^9\text{Be}(p, \gamma){}^{10}\text{B}$ ^a

E_p (MeV \pm keV)	E_x (MeV \pm keV)	$\Gamma_{c.m.}$ (keV)	$J^\pi; T$	Γ_p/Γ	Γ_γ (eV)
0.319	6.873 ± 5	120 ± 5	$1^-; 0+1$	0.30	4.8
0.938 ± 10	7.430	140 ± 30	$2^{(-)}; 0+1$	0.7	2.4
(0.98)	(7.47)		(2^+)		
0.992 ± 2	7.478	72 ± 4	$2^-; 1^c$	≈ 0.65	25.8
1.0832 ± 0.4	7.5599	2.65 ± 0.18	$0^+; 1$	1.0	8.5
1.29	7.75	210 ± 60	$2^-; (1)$	≈ 0.65	8.5
2.567 ± 2	8.894	36 ± 2	$2^+; 1$		
4.72^b	10.83	≈ 500	$2^+, 3^+, 4^+$		
6.7^b	12.6	< 200	$0^+, 1^+, 2^+$		
(7.0) ^b	(12.9)	(≈ 100)	($\pi = +$)		
7.5^b	13.3	≈ 300	$0^+, 1^+, 2^+$		
8.4^b	14.1	≈ 250	$0^+, 1^+, 2^+$		
8.9^b	14.6	≈ 150	$2^+, 3^+, 4^+$		
10.0^b	15.6	≈ 400	$2^+, 3^+, 4^+$		
14.6^b	19.7	≈ 500	$2^-, 3^-, 4^-$		

^a For references and for additional comments see Table 10.11 in (1979AJ01). See Table 10.11 for decay schemes.

^b Unpublished Ph.D. thesis.

^c See (1974AJ01). This state is assigned $J^\pi = 2^+$ on the basis of the (e, e') work (see Table 10.15). I am indebted to Dr. D. Kurath for his comments.

The yield of protons has been measured for $E({}^3\text{He}) = 0.60$ to 4.8 MeV: there is some indication of weak maxima at 1.1, 2.3 and 3.3 MeV. Measurements of A_y for the ground-state group at $E({}^3\vec{\text{He}}) = 14$ MeV (1983LE17, 1983RO22) and 33 MeV (1983LE17) and of the polarization at $E({}^3\text{He}) = 14$ MeV (1984ME11, 1984TR03) have been reported. $P = A$ in this and in the inverse reaction [see reaction 4 in ${}^{12}\text{C}$ (1985AJ01) for some additional comments]. For earlier references see (1984AJ01). See also (1986AB10; theor.).

8. (a) ${}^7\text{Li}({}^3\text{He}, d){}^8\text{Be}$ $Q_m = 11.7606$ $E_b = 17.7873$
 (b) ${}^7\text{Li}({}^3\text{He}, t){}^7\text{Be}$ $Q_m = -0.880$
 (c) ${}^7\text{Li}({}^3\text{He}, {}^3\text{He}){}^7\text{Li}$

Table 10.11: Radiative transitions in ${}^9\text{Be}(p, \gamma){}^{10}\text{B}$ ^a

Initial state (MeV)	$J^\pi; T$	Γ_γ (tot) (eV)	Relative intensities to final states								
			ground $3^+; 0$	0.72 $1^+; 0$	1.74 $0^+; 1$	2.15 $1^+; 0$	3.59 $2^+; 0$	5.11 $2^-; 0$	5.16 $2^+; 1$	5.18 $1^+; 0$	5.92 $2^+; 0$
6.87 $E_p = 0.32$	$1^-; 0 + 1$	4.8	< 0.05	0.20 ± 0.02	0.53 ± 0.02	0.13 ± 0.01	< 0.01	0.04 ± 0.01	0.03 ± 0.01	< 0.01	0.035 ± 0.01
7.43 $E_p = 0.94$	$2^{(-)}; 0 + 1$	[2.4]	< 2	1.3	[< 0.14]	0.62	0.5			[< 1]	
7.48 $E_p = 0.99$	$2^+; 1$	[25.8]	25	0.3	[< 0.14]	0.49	0			[< 1]	
7.56 $E_p = 1.08$	$0^+; 1$	[8.5]	< 0.2	6.7	< 0.3	0.8	< 0.2			1.0	
7.75 ^b $E_p = 1.29$	$(2^-; 1)$	[8.5]	6.6	0.9	< 0.08	0.3	0.3			0.4	

^a For references and other values see Table 10.12 in (1979AJ01).

^b See, however, Table 10.12.

Yields of deuterons have been measured for $E(^3\text{He}) = 1.0$ to 2.5 MeV (d_0) and yields of tritons are reported for 2.0 to 4.2 MeV (t_0): a broad peak is reported at $E(^3\text{He}) \approx 3.5$ MeV in the t_0 yield. See (1979AJ01) for references. Polarization measurements are reported at $E(^3\vec{\text{He}}) = 33.3$ MeV for the deuteron groups to $^8\text{Be}^*(16.63, 17.64, 18.15)$ and for the triton and ^3He groups to $^7\text{Be}^*(0, 0.43)$ and $^7\text{Li}^*(0, 0.48, 4.63)$: see (1984AJ01).

9. $^7\text{Li}(^3\text{He}, \alpha)^6\text{Li}$

$$Q_m = 13.328$$

$$E_b = 17.7873$$

Excitation functions have been measured for $E(^3\text{He}) = 1.3$ to 18.0 MeV: see (1974AJ01). The α_0 group (at 8°) shows a broad maximum at ≈ 2 MeV, a minimum at 3 MeV, followed by a steep rise which flattens off between $E(^3\text{He}) = 4.5$ and 5.5 MeV. Integrated α_0 and α_1 yields rise monotonically to 4 MeV and then tend to decrease. Angular distributions give evidence of the resonances at $E(^3\text{He}) = 1.4$ and 2.1 MeV seen in $^7\text{Li}(^3\text{He}, \gamma)^{10}\text{B}$: $J^\pi = 2^+$ or 1^- , $T = (1)$ for both [see, however, reaction 5]: Γ_α is small. The α_2 yield [to $^6\text{Li}^*(3.56)$, $J^\pi = 0^+$, $T = 1$] shows some structure at $E(^3\text{He}) = 1.4$ MeV and a broad maximum at ≈ 3.3 MeV: see Table 10.10 in (1979AJ01). Polarization measurements are reported at $E(^3\vec{\text{He}}) = 33.3$ MeV to $^6\text{Li}^*(0, 2.19, 3.56)$: see (1984AJ01). See also (1983AN1D, 1984PA1E).

10. $^7\text{Li}(\alpha, n)^{10}\text{B}$

$$Q_m = -2.7905$$

Angular distributions are reported at $E_\alpha = 28$ and 32 MeV for the n_0 , n_1 and n_2 groups (1985GUZQ; prelim.). See (1979AJ01, 1984AJ01) for the earlier work.

11. $^9\text{Be}(p, \gamma)^{10}\text{B}$

$$Q_m = 6.5857$$

Parameters of observed resonances are listed in Tables 10.10 and 10.11. Table 10.6 summarizes the γ -transitions from this and other reactions. For references to the discussion below, see (1974AJ01, 1979AJ01, 1984AJ01).

The $E_p = 0.32$ MeV resonance ($^{10}\text{B}^* = 6.87$ MeV) is ascribed to s-wave protons because of its comparatively large proton width [see $^9\text{Be}(p, p)$] and because of the isotropy of the γ -radiation. The strong transition to $^{10}\text{B}^*(1.74)$ requires E1 and hence $J^\pi = 1^-$, $T = 0$. $T = 0$ is also indicated by the large deuteron width. On the other hand, the strength of E1 transitions to $^{10}\text{B}^*(0.7, 2.1)$ indicates $T = 1$. The amplitudes for the $T = 0$ and $T = 1$ parts of the wave function for $^{10}\text{B}^*(6.87)$ are 0.92 and 0.39 , respectively. For the $5.16 \rightarrow 1.74$ decay see Table 10.6. The proton capture data near $E_p = 1$ MeV appears to require at least five resonant states, at $E_p = 938, (980), 992, 1083$ and 1290 keV. The narrow $E_p = 1083$ keV level ($^{10}\text{B}^* = 7.56$ MeV) is formed by p-wave protons, $J^\pi = 0^+$ [see $^9\text{Be}(p, p)$, $^9\text{Be}(p, \alpha)$]. The isotropy of the γ -rays supports this

assignment. The strong M1 transitions to $J^\pi = 1^+$, $T = 0$ levels at 0.72, 2.15 and 5.18 MeV (Table 10.11) indicate $T = 1$. The width of $^{10}\text{B}^*(5.18)$ observed in the decay is 100 ± 10 keV.

The excitation function for ground-state radiation shows resonance at $E_p = 992$ ($\Gamma = 80$ keV) and 1290 keV ($\Gamma = 230$ keV). Elastic scattering studies indicate s-wave formation and $J^\pi = 2^-$ for both. For the lower level ($E_x = 7.48$ MeV) the intensity of the g.s. capture radiation, $\Gamma_\gamma = 25$ eV indicates E1 and $T = 1$. The angular distribution of γ -rays, $1 + 0.1 \sin^2 \theta$, is consistent with s-wave formation with some d-wave admixture or with some contribution from a nearby p-wave resonance; possibly a $J^\pi = 2^+$ level at $E_p = 980$ keV.

The angular distribution of ground-state radiation at $E_p = 1330$ keV is isotropic and $\Gamma_\gamma = 8.5$ eV, supporting E1, $T = 1$ for this level ($E_x = 7.75$ MeV).

Transitions to $^{10}\text{B}^*(0.7)$ [γ_1] show resonance at $E_p = 992$, 1290 and 938 keV, $\Gamma = 155$ keV. The latter is presumably also a resonance for (p, d) and (p, α). An assignment of $J^\pi = 2^-$, $T = 0$ is consistent with the data, although the E1 radiation then seems somewhat too strong for a $\Delta T = 0$ transition.

A resonance for capture radiation at $E_p = 2.567 \pm 0.003$ ($E_x = 8.895$ MeV) has a width of 40 ± 2 keV and decays mainly via $^{10}\text{B}^*(0.7)$ (unpublished Ph.D. thesis). It appears from the width that this resonance corresponds to that observed in $^9\text{Be}(p, \alpha)$, $J^\pi = 2^+$, $T = 1$ and not to the $^9\text{Be}(p, n)$ resonance at the same energy. A further resonance is reported at $E_p = 4.72 \pm 0.01$ MeV, $\Gamma \approx 0.5$ MeV.

In the range $E_p = 4$ to 18 MeV, the γ_0 yield at 90° shows [unpublished Ph.D. thesis] the resonance at $E_p = 4.7$ MeV ($E_x = 10.7$ MeV) and fluctuations suggest states at $E_x \approx 14.6$, 15.6 and 19.7 MeV. $^{10}\text{B}^*(19.7)$ possibly decays via E1 and therefore $J^\pi = 2^-, 3^-, 4^-$. The other three states presumably decay by M1 and therefore $J^\pi = 2^+, 3^+, 4^+$. These fluctuations appear on a nearly constant γ_0 yield with a 90° differential cross section $\approx 1.5 \mu\text{b/sr}$. The average yield of γ_1 is $\approx \frac{2}{3}$ of the γ_0 yield. The broad giant resonance peak is centered at $E_x \approx 14.5$ MeV. Fluctuations in the γ_1 yield are reported at $E_x \approx 12.6$, 13.3 and 14.1 MeV. These states presumably decay by M1 to $^{10}\text{B}^*(0.7)$ [$J_f^\pi = 1^+$] and therefore $J_i^\pi = 0^+, 1^+, 2^+$. The weak γ_2 yield (to $^{10}\text{B}^*(1.74)$ [$J^\pi; T = 0^+; 1$]) seems to exhibit a broad peak centered near $E_x = 15$ MeV (maximum 90° differential cross section $\approx 0.5 \mu\text{b/sr}$) and possibly some structure near $E_x = 20$ MeV. The γ_3 yield (to $^{10}\text{B}^*(2.15)$ [$J^\pi = 1^+$]) increases to $\approx 0.4 \mu\text{b/sr}$ at $E_x \approx 16$ MeV and seems to remain constant beyond that energy, with some suggestion of a fluctuation corresponding to $E_x \approx 12.9$ MeV. $^{10}\text{B}^*(12.9)$ appears to have positive parity. Angular distributions of γ_0 , γ_1 , γ_2 and γ_3 are also reported [in an unpublished Ph.D. thesis].

The magnetic moment of $^{10}\text{B}^*(0.72)$ has been studied via γ - γ correlations from $^{10}\text{B}^*(7.56)$: $g = +0.63 \pm 0.12$. See also (1985KI1B, 1985NE1C; applications), (1984YA1A; astrophysics) and (1983GO28, 1986NA15; theor.).

12. $^9\text{Be}(p, n)^9\text{B}$

$$Q_m = -1.851$$

$$E_b = 6.5857$$

Resonances in the neutron yield occur at $E_p = 2562 \pm 6$, 4720 ± 10 and, possibly, at 3500 keV with $\Gamma_{\text{c.m.}} = 84 \pm 7$, ≈ 500 and ≈ 700 keV. These three resonances correspond to $^{10}\text{B}^*(8.890$,

10.83, 9.7): see Table 10.13 in (1974AJ01). Cross section measurements for the (p, n) and (p, n₀) reactions have been obtained by (1983BY01; $E_p = 8.15$ to 15.68 MeV) [see also for a review of earlier work]. They indicate possible structure in ^{10}B near 13–14 MeV (1983BY01).

The $E_p = 2.56$ MeV resonance is considerably broader than that observed at the same energy in $^9\text{Be}(p, \alpha)$ and $^9\text{Be}(p, \gamma)$ and the two resonances are believed to be distinct. The shape of the resonance and the magnitude of the cross section can be accounted for with $J^\pi = 3^-$ or 3^+ ; the former assignment is in better accord with $^{10}\text{Be}^*(7.37)$. For $J^\pi = 3^-$, $\theta_n^2 = 0.135$, $\theta_p^2 = 0.115$ ($R = 4.47$ fm): see (1974AJ01).

The analyzing power for n₀ has been measured for $E_p = 2.7$ to 17 MeV (1980MA33, 1983BY02, 1986MU07) as has the polarization in the range $E_p = 2.7$ to 10 MeV (1983BY02). See (1983BY02, 1986MU07) for discussions of the $\sigma(\theta)$, $A_y(\theta)$ and $P(\theta)$ measurements. Polarization measurements have also been reported at $E_{\bar{p}} = 3.9$ to 15.1 MeV and 800 MeV: [see (1984AJ01)] and at 53.5 , 53.9 and 71.0 MeV (1988HE08) [K_y^y , K_z^z]. See also ^9B , (1985TE1C), (1985CA41; astro-phys.), (1986AL1J; applications) and (1988ZVZZ; theor.).

13. (a) $^9\text{Be}(p, p)^9\text{Be}$		$E_b = 6.5857$
(b) $^9\text{Be}(p, pn)^8\text{Be}$	$Q_m = -1.6654$	
(c) $^9\text{Be}(p, p\alpha)^5\text{He}$	$Q_m = -2.47$	

The elastic scattering has been studied for $E_p = 0.2$ to 9.5 MeV [see (1974AJ01, 1979AJ01, 1984AJ01)] and at $E_p = 2.0$ to 3.8 MeV (1983AL10). Below $E_p = 0.7$ MeV only s-waves are present exhibiting resonance at $E_p = 330$ keV [$^{10}\text{B}^*(6.88)$], $J^\pi = 1^-$. Between $E_p = 0.8$ to 1.6 MeV polarization and cross-section measurements are well fitted by a phase-shift analysis, using only the $^3\text{S}_1$, $^5\text{S}_2$, $^5\text{P}_1$ and $^5\text{P}_2$ phases. Four levels satisfy the data, 1^+ and 2^- states at $E_x = 7.48$ MeV, a sharp 0^+ state at $E_x = 7.56$ MeV, and a 1^- state at 7.82 MeV: see Table 10.12. Pronounced minima at $E_p = 2.48$ and 2.55 MeV are observed in the polarization (p_0): these are ascribed to $T = 1$ analogs of the 3^- and 2^+ states $^{10}\text{Be}^*(7.37, 7.52)$. A strong anomaly is observed at $E_p = 6.7$ MeV: see Table 10.12.

Polarization measurements have been reported at $E_p = 0.9$ to 49.8 MeV, at 138.2 and 145 MeV, and at 990 MeV [see (1974AJ01, 1979AJ01)] as well as at $E_{\bar{p}} = 780$ MeV and at 1 GeV [see (1984AJ01)]. Recently, A_y measurements have been reported at $E_{\bar{p}} = 200$ MeV (1985GLZZ; p_0 ; prelim.) and 220 MeV (1985RO15; p_0, p_2). For inclusive proton scattering at $E_{\bar{p}} = 303$ MeV see (1987MO04). See also (1985SE15). For reaction (b) see (1984WA21, 1986MEZZ, 1988BO47). Reaction (c) at $E_{\bar{p}} = 150.5$ MeV has been studied by (1985WA13; A_y). For other high energy studies see (1984AJ01). See also ^9Be , (1982BA78, 1985RO1C, 1985TR1A, 1986KO1R), (1984ZU01, 1985SA1G, 1986BA88, 1986MU07) and (1983KA37, 1984SH1K, 1985DY03, 1986HA1K; theor.).

14. (a) $^9\text{Be}(p, t)^7\text{Be}$	$Q_m = -12.082$	$E_b = 6.5857$
(b) $^9\text{Be}(p, ^3\text{He})^7\text{Li}$	$Q_m = -11.2016$	

Table 10.12: Resonances in ${}^9\text{Be}(p, p){}^9\text{Be}$ ^a

E_{res} (keV)	E_x (MeV)	$\Gamma_{\text{c.m.}}$ (keV)	J^π	Γ_p/Γ
330	6.88	145	1^-	0.30
980 ± 10	7.467	65 ± 10	1^+	1.0
980 ± 10	7.467	80 ± 8	2^- ^d	0.90 ± 0.05
1084 ± 2	7.561	2.7	0^+	1.0
(1200 ± 30)	(7.67)	250 ± 20	(1^+)	0.30 ± 0.10
1370 ± 20	7.818	265 ± 30	1^-	0.90 ± 0.05
(2070 ± 10)	(8.4)	70 ± 10	$(1^-, 2^-)$	0.43
(2300)	(8.65)	≈ 300	$(1^+, 2^+)$	
(2480)	(8.82)		$(3^-; 1)$	
2560	8.89		$\geq 2; (1)^c$	large
(4600)	(10.7)			
(5100)	(11.2)			
6700^b	12.6	broad		

^a For references and for a listing of other reported resonances see Table 10.13 in (1979AJ01). Nine anomalies in the p_0 yield are reported by (1983AL10) at $E_p = 2.07, 2.30, 2.44, 2.55, 2.56, 2.60, 3.80, 4.20$ and 4.72 MeV.

^b Weak resonance near $E_p = 6.5$ MeV in p_0 .

^c Resonance shape shows $l_p = 2$ formation with a large Γ_p/Γ : the contribution from the 2^+ state appears small.

^d See, however, Table 10.15 and footnote ^a in Table 10.13 of (1979AJ01).

Polarization measurements (reaction (b)) are reported at $E_p = 23.06$ MeV: see (1984AJ01). For a study at $E_p = 190$ and 300 MeV see (1987GR11). See also (1985SE15).

$$\begin{array}{lll}
 15. (a) {}^9\text{Be}(p, d){}^8\text{Be} & Q_m = 0.5592 & E_b = 6.5857 \\
 (b) {}^9\text{Be}(p, \alpha){}^6\text{Li} & Q_m = 2.126 &
 \end{array}$$

Knowledge of the cross sections of these two reactions at low energies is of importance for power generation and astrophysical considerations. Absolute cross sections for the d_0 and α_0 groups have been measured for $E_p = 28$ to 697 keV with ± 5 – 6% uncertainty. The value of $S_{\text{c.m.}}(E = 0)$ for the combined cross sections is estimated to be 35_{-15}^{+45} MeV·b. At the 0.33 MeV resonance ($J^\pi = 1^-$), $\sigma_{\alpha_0} = 360 \pm 20$ mb and $\sigma_{d_0} = 470 \pm 30$ mb. The data (including angular

Table 10.13: Resonances in ${}^9\text{Be}(p, d){}^8\text{Be}$ and ${}^9\text{Be}(p, \alpha){}^6\text{Li}$ ^a

E_p (MeV)	E_x (MeV)	$\Gamma_{\text{c.m.}}$ (keV)	$J^\pi; T$	Γ_p/Γ
0.34	6.89		$1^-; 0$	0.30
0.46	7.00		$1^+(2^+, 3^+)$ ^d	
(0.69)	(7.20)			
0.94	7.43	140	$(2^-; 0)$	0.7
1.15	7.62	225 ± 50	$(1^+; 0)$	≈ 0.4
1.65	8.07	800 ± 200	$(2^-; 0)$	≈ 0.07
(2.3)	(8.7)	(≈ 220)		
2.56 ^b	8.89	36 ± 2	$2^+; 1$	
3.5 ^c	9.7		$T = 1$	
4.49 ^c	10.62		$T = 1$	

^a For references and for a listing of other reported resonances and additional information see Table 10.14 in (1979AJ01).

^b (1977KI04) have analyzed the $(\alpha_2\gamma)$ and p_0 yields with an R -matrix formalism and find the following parameters

$$\left. \begin{array}{l} 2.566 \pm 0.001 \quad 2^+ \\ 2.561_{-2}^{+10} \quad 3^- \end{array} \right\} \Gamma_{\text{c.m.}} = \left\{ \begin{array}{l} 40 \pm 1 \text{ keV}, \\ 100 \pm 20 \text{ keV}. \end{array} \right.$$

^c Resonance for α_2 to ${}^6\text{Li}^*(3.56)$, $J^\pi = 0^+$, $T = 1$.

^d See, however, Table 10.8.

distributions), analyzed by an R -matrix compound nucleus model, were fitted by assuming three states at $E_p(\text{c.m.}) = -20$ keV ($J^\pi = 2^+; 3^+$ possible) [$E_x = 6.57$ MeV] [see, however, Table 10.8], 310 keV (1^-) and 410 keV ($1^+; 2^+$ or 3^+ possible): see (1979AJ01). See also (1988ABZW).

Measurements of excitation functions for deuterons and α -particles have been reported at a number of energies to $E_p = 15$ MeV: see (1974AJ01, 1979AJ01). Observed resonances are displayed in Table 10.13.

Polarization measurements have been made in the range $E_p = 0.30$ to 15 MeV and at 185 MeV [see (1974AJ01, 1979AJ01)] and at $E_p = 60$ MeV (1987KA25; A_y ; inclusive deuteron spectra). For a fragmentation study at $E_p = 190$ and 300 MeV see (1987GR11). See also (1983AN1D, 1984BA1L, 1985SE15, 1986ER1B), (1984YA1A, 1985CA41; astrophysics), (1984PA1E) and (1982BR1A; theor.).

16. ${}^9\text{Be}(d, n){}^{10}\text{B}$

$$Q_m = 4.3612$$

Neutron groups are observed corresponding to the ^{10}B states listed in Table 10.14. Angular distributions have been measured for $E_d = 0.5$ to 16 MeV [see (1974AJ01, 1979AJ01)], at 8 MeV (1986BA40; $n_0 \rightarrow n_5, n_{6+7+8}$; also at 4 MeV to the latter) and at 18 MeV (1987KAZL; n_0, n_1). Observed γ -transitions are listed in Table 10.16 of (1979AJ01). See Tables 10.6 and 10.7 here for the parameters of radiative transitions and for τ_m .

From all the various experiments the following picture emerges: the first five states of ^{10}B have even parity [from l_p]. The ground state is known to have $J = 3$, by direct measurement, and $^{10}\text{B}^*(1.74)$ has $J^\pi = 0^+$ and is the $T = 1$ analog of the $^{10}\text{C}_{\text{g.s.}}$ [from the β^+ decay of ^{10}C]. Then looking at the branching ratios and lifetimes of the other states, the sequence for $^{10}\text{B}^*(0, 0.72, 1.74, 2.15, 3.59)$ is $J^\pi = 3^+, 1^+, 0^+, 1^+, 2^+$ [see discussion in (1966LA04, 1966WA10)].

See also ^{11}B in (1985AJ01), (1983TA17, 1985SM08) and (1986OV1A; applications).

$$17. \ ^9\text{Be}(^3\text{He}, d)^{10}\text{B} \quad Q_m = 1.0922$$

Deuteron groups have been observed to a number of states of ^{10}B : see Table 10.14. Angular distributions have been reported at $E(^3\text{He}) = 10$ to 33.3 MeV [see (1974AJ01, 1979AJ01, 1984AJ01)]. Spectroscopic factors obtained in the (d, n) and (^3He , d) reactions are not in good agreement: see the discussions in (1974KE06, 1980BL02). See also (1986AV01; theor.).

$$18. \ ^9\text{Be}(\alpha, t)^{10}\text{B} \quad Q_m = -13.2282$$

Angular distributions have been studied at $E_\alpha = 27, 28.3$ and 43 MeV [see (1979AJ01)], at 30.2 MeV (1984VA07; t_0, t_1, t_3, t_4) and at 65 MeV (1980HA33). In the latter experiment DWBA analyses have been made of the distributions to $^{10}\text{B}^*(0, 0.72, 1.74, 2.15, 3.59, 5.2, 5.92, 6.13, 6.56, 7.00, 7.5, 7.82, 8.9)$ and spectroscopic factors were derived. The distributions to $^{10}\text{B}^*(4.77, 6.03)$ could not be fitted by either DWBA or coupled channel analyses. In general coupled-channels calculations give a better fit to the 65 MeV data than does DWBA (1980HA33; see also for a comparison with the (d, n) and (^3He , d) results).

$$19. \ ^9\text{Be}(^7\text{Li}, ^6\text{He})^{10}\text{B} \quad Q_m = -3.389$$

At $E(^7\text{Li}) = 34$ MeV angular distributions have been obtained for the ^6He ions to the first four states of ^{10}B . Absolute values of the spectroscopic factors are $S = 0.88, 1.38$ ($p_{1/2}$ or $p_{3/2}$), 1.40 and 0.46 ($p_{1/2}$), 0.54 ($p_{3/2}$) for $^{10}\text{B}^*(0, 0.74, 1.74, 2.15)$ (FRDWBA analysis): see (1979AJ01). See also (1988AL1G).

$$20. \ ^{10}\text{Be}(\beta^-)^{10}\text{B} \quad Q_m = 0.5561$$

Table 10.14: Levels of ^{10}B from $^9\text{Be}(\text{d}, \text{n})$ and $^9\text{Be}({}^3\text{He}, \text{d})$ ^a

E_x (MeV) ^a	$^9\text{Be}(\text{d}, \text{n})$ ^b		$^9\text{Be}({}^3\text{He}, \text{d})$ ^c		$J^\pi; T$ ^a
	l_p	S_{rel}	l_p	$(2J + 1)C^2S$	
0	1	1.0	1	3.30	$3^+; 0$
0.72	1	1.97	1	2.76	$1^+; 0$
1.74	1	1.36	1	1.20	$0^+; 1$
2.15	1	0.41	1	0.82	$1^+; 0$
3.59	1	0.10	1	0.29	$2^+; 0$
4.77	(≥ 2)		$1 + (3)^e$	0.10	$3^+; 0$
				≤ 0.82	
5.11	0	0.14	$0 + 2$	0.34, 0.14	$2^-; 0$
5.16	}	0.43	1	0.86	$2^+; 1$
5.18					$1^+; 0$
5.92	1	0.49	1	2.05	$2^+; 0$
6.03			$(3)^e$	≤ 0.20	4^+
6.13	(2)		$(2)^f$	3.04	3^-
6.56	(3)		$(2)^f$	2.01	$(4)^-$
6.89 ± 15	(1)				$1^-; 0 + 1$
7.00 ± 15	(1)				$(1, 2)^+; (0)$
7.48 ± 15	d				^g
7.56 ± 25	d				$0^+; 1$
(7.85 ± 50)	d				1^-
(8.07 ± 50)	d				$(2^-; 0)$
(8.12 ± 50)	d				

^a Values without uncertainties are from Table 10.5; others are from Table 10.15 in (1979AJ01).

See that table for additional information and for references. See also (1984AJ01).

^b S_{rel} from experiment at $E_d = 12.0 - 16.0$ MeV.

^c $E({}^3\text{He}) = 18$ MeV; DWBA analysis; values shown are those obtained with one of the two optical-model potentials used in the analysis. For earlier (${}^3\text{He}, \text{d}$) results see Table 10.17 in (1979AJ01).

^d State observed in (d, n) reaction; l_p not determined.

^e Angular distribution poorly fitted by DWBA.

^f See (1980BL02) for a discussion of these two states, including a comparison with the (d, n) data: $l_p = 2$ is slightly preferred to $l_p = 1$ on the basis of the observed strengths. Neither $l_p = 2$ nor 1 gives a good DWBA fit.

^g Group shown corresponds to unresolved states in ^{10}B .

See ^{10}Be .

21. $^{10}\text{Be}(p, n)^{10}\text{B}$ $Q_m = -0.2261$

The yield of the n_1 group has been studied for $E_p = 0.9$ to 2.0 MeV: see ^{11}B in (1990AJ01) (1986TE1A).

22. (a) $^{10}\text{B}(\gamma, n)^9\text{B}$ $Q_m = -8.436$
(b) $^{10}\text{B}(\gamma, p)^9\text{Be}$ $Q_m = -6.5857$
(c) $^{10}\text{B}(\gamma, pn)^8\text{Be}$ $Q_m = -8.2511$
(d) $^{10}\text{B}(\gamma, \pi^+)^{10}\text{Be}$ $Q_m = -140.125$

Absolute measurements have been made of the $^{10}\text{B}(\gamma, \text{Tn})$ cross section from threshold to 35 MeV with quasimonoenergetic photons; the integrated cross section is 0.54 in units of the classical dipole sum ($60 NZ/A$ MeV·mb). The $(\gamma, 2n) + (\gamma, 2np)$ cross section is zero, within statistics, for $E_\gamma = 16$ to 35 MeV: see (1979AJ01) and (1988DI02). The giant resonance is broad with the major structure contained in two peaks at $E_x = 20.1 \pm 0.1$ and 23.1 ± 0.1 MeV ($\sigma_{\text{max}} \approx 5.5$ mb for each of the two maxima): see (1979AJ01). (1987AH02) [and H. H. Thies, private communication] [using bs] report two broad [$\Gamma \approx 2$ MeV] maxima at 20.2 and 23.0 MeV [± 0.05 MeV] ($\sigma = 5.0$ and 6.0 mb, respectively; $\pm 10\%$) and a minor structure at $E_x = 17.0$ MeV. For reactions (b) and (c) see (1988SU14). For reaction (d) see ^{10}Be . See also (1974AJ01) and (1983GO28, 1985GO1A, 1987KI1C; theor.).

23. (a) $^{10}\text{B}(e, e)^{10}\text{B}$
(b) $^{10}\text{B}(e, en)^9\text{B}$ $Q_m = -8.436$
(c) $^{10}\text{B}(e, ep)^9\text{Be}$ $Q_m = -6.5857$
(d) $^{10}\text{B}(e, e\pi^+)^{10}\text{Be}$ $Q_m = -140.125$

$$\langle r^2 \rangle^{1/2} = 2.49 \pm 0.09 \text{ fm (1986DO1E; prelim.)}$$

Inelastic electron groups are displayed in Table 10.15. (1986FRZZ; prelim.) have measured the form factors for $^{10}\text{B}^*(0, 1.74, 5.16)$. For reactions (b) and (c) see (1984AJ01). For reaction (d) see ^{10}Be . See also (1984DO20, 1986PE05, 1987DE43, 1987HI1F) and (1986HA1M; theor.).

24. $^{10}\text{B}(n, n)^{10}\text{B}$

Table 10.15: Radiative widths for $^{10}\text{Be}(e, e')$ ^a

E_x in ^{10}B (MeV)	$J^\pi; T$	Mult.	Γ_{γ_0} (eV)
1.74	$0^+; 1$	M3	$(1.05 \pm 0.25) \times 10^{-7}$
5.16 ± 0.04 ^b	$2^+; 1$	{ M1	0.05 ± 0.05
		{ M3	$(1.1 \pm 0.1) \times 10^{-6}$
6.03	4^+	{ C2	0.106 ± 0.005
		{ C4	$(3.3 \pm 0.8) \times 10^{-7}$
7.48	$2^+; 1$	M1	11.75 ± 0.75
8.07	2^+ ^c	C2	0.19 ± 0.02
8.9	$2^+; 1$	{ M1	0.3 ± 0.1
		{ M3	$(1.0 \pm 0.1) \times 10^{-5}$
	$3^-; 1$	M2	$(1.2 \pm 0.1) \times 10^{-3}$
10.79		M1 or C2	
11.56		(M1)	11.4 ± 2.3 ^c
12.6			
13.3			

^a See Table 10.16 in (1984AJ01) for references. See also Table 10.18 in (1979AJ01).

^b Assumed to correspond to 2^+ state at 5.16 MeV. $\Gamma_{\gamma_0} = (3.5 \pm 0.3) \times 10^{-4}$ eV for M2 if the transition were to the 2^- state at 5.11 MeV: see also footnote ^g in Table 10.18 (1979AJ01).

^c $\Gamma \approx 760$ keV.

Angular distributions have been studied for $E_n = 1.5$ to 14.1 MeV [see (1974AJ01, 1979AJ01)] and at 3.02 to 12.01 MeV (1986SAZR, 1987SAZX; prelim; $n_1 \rightarrow n_5$), 8 to 14 MeV (1983DA22; n_0) and 9.96 to 16.94 MeV (1986MU08; prelim.; n_0). See also ^{11}B in (1985AJ01, 1990AJ01), (1984TU02) and (1983KO1F; theor.).

25. (a) $^{10}\text{B}(p, p)^{10}\text{B}$

(b) $^{10}\text{B}(p, 2p)^9\text{Be}$ $Q_m = -6.5857$

Angular distributions have been measured for a number of energies between $E_p = 3.0$ and 800 MeV [see (1974AJ01, 1979AJ01, 1984AJ01)] and at 10 to 17 MeV (1986MU08; p_0 ; prelim.). Table 10.16 displays the states observed in this reaction. The γ -ray results are shown in Table 10.6. See also (1979AJ01). For τ_m see Table 10.7 (1983VE03).

Table 10.16: ^{10}B levels from $^{10}\text{B}(\text{p}, \text{p})$, $^{10}\text{B}(\text{d}, \text{d})$ and $^{10}\text{B}({}^3\text{He}, {}^3\text{He})$ ^a

E_x (MeV \pm keV) ^b	$\Gamma_{\text{c.m.}}$ (keV)	L	β_L ^{b, c}
0 ^d			
0.7183 \pm 0.4 ^{d, e, f} \equiv 1.7402 ^{f, g}		2 (3)	0.67 \pm 0.05
2.1541 \pm 0.5 ^d		2	0.49 \pm 0.04
3.5870 \pm 0.5 ^d		2	0.45 \pm 0.04
4.7740 \pm 0.5 ^h			
5.1103 \pm 0.6		3	0.45 \pm 0.04
5.1639 \pm 0.6			
5.18 \pm 10 ^{h, i}	110 \pm 10		
5.9195 \pm 0.6 ^d	< 5		0.28 \pm 0.03
6.0250 \pm 0.6 ^d	< 5	2	0.95 \pm 0.04
6.1272 \pm 0.7 ^d	< 5	3	0.58 \pm 0.03
6.55 \pm 10 ^d	25 \pm 5	3	0.46 \pm 0.04 ^j
7.00 \pm 10 ^d	95 \pm 10		
7.48 \pm 10	90 \pm 15		

^a For references and a more complete presentation see Table 10.19 in (1979AJ01).

^b From (p, p).

^c See results obtained from (${}^3\text{He}$, ${}^3\text{He}$) in Table 10.19 of (1979AJ01).

^d Also observed in (d, d) and (${}^3\text{He}$, ${}^3\text{He}$).

^e $E_x = 718.35 \pm 0.04$ (from E_γ).

^f $E_x = 718.5 \pm 0.2$ and 1740.0 ± 0.6 keV (from E_γ).

^g Also observed in (${}^3\text{He}$, ${}^3\text{He}$).

^h Also observed in (d, d).

ⁱ Not reported in (p, p) at $E_p = 10$ MeV.

^j If $J^\pi = 4^-$; $\beta_L = 0.59 \pm 0.03$ if $J^\pi = 2^-$.

Axions may cause e^+e^- pairs in competition with γ -ray emission in an isoscalar M1 transition: a search for axions was undertaken in the case of the $3.59 \rightarrow \text{g.s. } [2^+ \rightarrow 3^+]$ transition. It was negative (1986DE25). A beam dump experiment and other attempts to observe axions are discussed in (1987HA10). For reaction (b) at $E_p = 1 \text{ GeV}$ see (1985BE30, 1985DO16; prelim.) and (1974AJ01). See also (1988KRZY), (1985KI1B, 1988KOZL; applied) and ^{11}C in (1985AJ01, 1990AJ01).

26. $^{10}\text{B}(d, d)^{10}\text{B}$

Angular distributions have been reported at $E_d = 4$ to 28 MeV : see (1974AJ01, 1979AJ01). Observed deuteron groups are displayed in Table 10.16. The very low intensity of the group to $^{10}\text{B}^*(1.74)$ and the absence of the group to $^{10}\text{B}^*(5.16)$ is good evidence of their $T = 1$ character: see (1974AJ01).

27. $^{10}\text{B}(t, t)^{10}\text{B}$

Angular distributions of elastically scattered tritons have been measured at $E_t = 1.5$ to 3.3 MeV : see (1974AJ01).

28. $^{10}\text{B}(^3\text{He}, ^3\text{He})^{10}\text{B}$

Angular distributions have been measured at $E(^3\text{He}) = 4$ to 46.1 MeV [see (1974AJ01, 1979AJ01, 1984AJ01)] and at 2.10 and 2.98 MeV (1987BA34; elastic). $L = 2$ gives a good fit of the distributions of ^3He ions to $^{10}\text{B}^*(0.72, 2.15, 3.59, 6.03)$: derived β_L are shown in Table 10.19 of (1979AJ01). See also Table 10.16 here, ^{13}N in (1986AJ01) and (1987RA36; theor.).

29. (a) $^{10}\text{B}(\alpha, \alpha)^{10}\text{B}$

(b) $^{10}\text{B}(\alpha, 2\alpha)^6\text{Li} \quad Q_m = -4.4596$

Angular distributions have been measured for $E_\alpha = 5$ to 56 MeV [see (1974AJ01, 1979AJ01, 1984AJ01)] and at 91.8 MeV (1985JA12; α_0). Reaction (b) has been studied at $E_\alpha = 24$ and 700 MeV : see (1979AJ01, 1984AJ01). See also (1983GO27, 1985SH1D; theor.).

30. (a) $^{10}\text{B}(^6\text{Li}, ^6\text{Li})^{10}\text{B}$

(b) $^{10}\text{B}(^7\text{Li}, ^7\text{Li})^{10}\text{B}$

Elastic-scattering angular distributions have been studied at $E(^6\text{Li}) = 5.8$ and 30 MeV and at $E(^7\text{Li}) = 24$ MeV: see (1979AJ01).

31. $^{10}\text{B}(^9\text{Be}, ^9\text{Be})^{10}\text{B}$

Elastic angular distributions have been measured at $E(^{10}\text{B}) = 20.1$ and 30.0 MeV (1983SR01). For yield and cross section measurements see (1983SR01, 1986CU02). See also (1984IN03, 1986RO12; theor.).

32. (a) $^{10}\text{B}(^{10}\text{B}, ^{10}\text{B})^{10}\text{B}$

(b) $^{10}\text{B}(^{11}\text{B}, ^{11}\text{B})^{10}\text{B}$

Elastic angular distributions (reaction (a)) have been studied at $E(^{10}\text{B}) = 8, 13$ and 21 MeV. For yields and reaction (b) see (1979AJ01). See also (1985BE1A, 1985CU1A) and (1984HA43, 1986RO12; theor.).

33. (a) $^{10}\text{B}(^{12}\text{C}, ^{12}\text{C})^{10}\text{B}$

(b) $^{10}\text{B}(^{13}\text{C}, ^{13}\text{C})^{10}\text{B}$

Elastic angular distributions have been measured at $E(^{10}\text{B}) = 18$ and 100 MeV for reaction (a) [see (1979AJ01)] and at 18 – 46 MeV [see (1984AJ01)] and $42.5, 62.3$ and 80.9 MeV for reaction (b) (1985MA10). For yield, cross section and fusion experiments see (1983DA20, 1983MA53, 1985MA10, 1988MA07) and (1984AJ01). See also (1984DEZX, 1984HAZK, 1987SAZW), (1982BA1D, 1985BA1T; astrophysics), (1983BI13, 1983DU13, 1984FR1A, 1984HA53, 1985BE1A, 1985CU1A, 1986MA19) and (1983HA1E, 1984HA43, 1984IN03, 1984MAZT, 1985KO1J, 1986RO12; theor.).

34. $^{10}\text{B}(^{14}\text{N}, ^{14}\text{N})^{10}\text{B}$

Angular distributions have been reported at $E(^{10}\text{B}) = 100$ MeV and $E(^{14}\text{N}) = 73.9$ and 93.6 MeV: see (1979AJ01, 1984AJ01). For fusion cross section studies see (1979AJ01, 1984AJ01) and (1983DE26). See also (1983BI13, 1983DA10, 1984FR1A, 1984HA53, 1985BE1A, 1985CU1A) and (1983GO13, 1984HA43, 1984IN03, 1985KO1J, 1986RO12; theor.).

35. (a) $^{10}\text{B}(^{16}\text{O}, ^{16}\text{O})^{10}\text{B}$

(b) $^{10}\text{B}(^{17}\text{O}, ^{17}\text{O})^{10}\text{B}$

(c) $^{10}\text{B}(^{18}\text{O}, ^{18}\text{O})^{10}\text{B}$

Elastic angular distributions (reaction (a)) have been studied at $E(^{16}\text{O}) = 15.0$ to 32.5 MeV and at $E(^{10}\text{B}) = 33.7$ to 100 MeV: see (1979AJ01, 1984AJ01). The elastic scattering for reaction (c) has been studied at $E(^{18}\text{O}) = 20, 24$ and 30.5 MeV: see (1974AJ01). For yield and fusion cross section measurements see (1984AJ01) and (1984GO05). See also (1983BI13, 1984FR1A, 1984HA53) and (1983GO13, 1985HU04; theor.).

36. (a) $^{10}\text{B}(^{19}\text{F}, ^{19}\text{F})^{10}\text{B}$
 (b) $^{10}\text{B}(^{20}\text{Ne}, ^{20}\text{Ne})^{10}\text{B}$

The elastic scattering has been investigated for $E(^{19}\text{F}) = 20$ and 24 MeV for reaction (a) and $E(^{10}\text{B}) = 65.9$ MeV for reaction (b): see (1974AJ01, 1984AJ01).

37. (a) $^{10}\text{B}(^{24}\text{Mg}, ^{24}\text{Mg})^{10}\text{B}$
 (b) $^{10}\text{B}(^{25}\text{Mg}, ^{25}\text{Mg})^{10}\text{B}$

The elastic scattering for both reactions has been studied at $E(^{10}\text{B}) = 87.4$ MeV: see (1984AJ01). The elastic scattering for reaction (b) has been measured at $E(^{10}\text{B}) = 34$ MeV by (1985WI18).

38. (a) $^{10}\text{B}(^{27}\text{Al}, ^{27}\text{Al})^{10}\text{B}$
 (b) $^{10}\text{B}(^{28}\text{Si}, ^{28}\text{Si})^{10}\text{B}$
 (c) $^{10}\text{B}(^{30}\text{Si}, ^{30}\text{Si})^{10}\text{B}$

The elastic scattering for all three reactions has been studied at $E(^{10}\text{B}) = 41.6$ and ≈ 50 MeV [and also at 33.7 MeV for reaction (b)]: see (1984AJ01). See also (1984TE1A).

39. (a) $^{10}\text{B}(^{39}\text{K}, ^{39}\text{K})^{10}\text{B}$
 (b) $^{10}\text{B}(^{40}\text{Ca}, ^{40}\text{Ca})^{10}\text{B}$

The elastic scattering has been studied at $E(^{10}\text{B}) = 44$ MeV for reaction (a) (1985WI18) and at 46.6 MeV for reaction (b): see (1984AJ01).

40. $^{10}\text{C}(\beta^+)^{10}\text{B}$ $Q_m = 3.6481$

The half-life of ^{10}C is 19.255 ± 0.53 sec [see (1974AJ01, 1979AJ01)]: the decay is to $^{10}\text{B}^*(0.72, 1.74)$ with branching ratios of $(98.53 \pm 0.02)\%$ and $(1.465 \pm 0.014)\%$ and $\log ft = 3.047$ for the transition to $^{10}\text{B}^*(0.72)$ and 3.492 ± 0.005 for that to the analog state, $^{10}\text{B}^*(1.74)$: see Table 10.20 in (1979AJ01). The excitation energies of the two states are 718.32 ± 0.09 and 1740.16 ± 0.17 keV [$E_\gamma = 718.29 \pm 0.09$ and 1021.78 ± 0.14 keV]. See (1979AJ01) for a further discussion of the decay. See also (1988GI02, 1988KRZY).

$$41. \quad ^{11}\text{B}(\gamma, n)^{10}\text{B} \qquad Q_m = -11.4542$$

The intensities of the transitions to $^{10}\text{B}^*(3.59, 5.16)$ [$T = 0$ and 1 , respectively] depend on the region of the giant dipole resonance in ^{11}B from which the decay takes place: it is suggested that the lower-energy region consists mainly of $T = \frac{1}{2}$ states and the higher-energy region of $T = \frac{3}{2}$ states: see ^{11}B in (1980AJ01). See also ^{11}B in (1985AJ01, 1990AJ01) and (1984AL22).

$$42. \quad \begin{array}{ll} \text{(a) } ^{11}\text{B}(p, d)^{10}\text{B} & Q_m = -9.2296 \\ \text{(b) } ^{11}\text{B}(p, pn)^{10}\text{B} & Q_m = -11.4542 \end{array}$$

Angular distributions of deuteron groups have been measured at several energies in the range $E_p = 17.7$ to 154.8 MeV [see (1979AJ01)] and at 18.6 MeV (1985BE13; d_0, d_1). The population of the first five states of ^{10}B and of $^{10}\text{B}^*(5.2, 6.0, 6.56, 7.5, 11.4 \pm 0.2, 14.1 \pm 0.2)$ is reported. For reaction (b) see (1985BE30, 1985DO16; 1 GeV; prelim.). See also (1988GUZW) and (1988BE11; theor.).

$$43. \quad ^{11}\text{B}(d, t)^{10}\text{B} \qquad Q_m = -5.1969$$

Angular distributions have been measured at $E_d = 11.8$ MeV ($t_0 \rightarrow t_3; l = 1$) [see (1974AJ01)] and at 18 MeV (1987GUZZ, 1988GUZW; prelim.).

$$44. \quad \begin{array}{ll} \text{(a) } ^{11}\text{B}(^3\text{He}, \alpha)^{10}\text{B} & Q_m = 9.1236 \\ \text{(b) } ^{11}\text{B}(^3\text{He}, 2\alpha)^6\text{Li} & Q_m = 4.6640 \end{array}$$

Reported levels are displayed in Table 10.17. Angular distributions have been measured at a number of energies between $E(^3\text{He}) = 1.0$ and 33 MeV [see (1974AJ01)] and at 23.4 MeV (1987VA11; α_0, α_1 ; prelim.). For the decay of observed states see Table 10.6.

The α - α angular correlations (reaction (b)) have been measured for the transitions via $^{10}\text{B}^*(5.92, 6.03, 6.13, 6.56, 7.00)$. The results are consistent with $J^\pi = 2^+$ and 4^+ for $^{10}\text{B}^*(5.92, 6.03)$ and

Table 10.17: ^{10}B levels from $^{11}\text{B}(^3\text{He}, \alpha)^{10}\text{B}$ ^a

E_x (MeV \pm keV)	$\Gamma_{\text{c.m.}}$ (keV)	l	S_{rel}
0		1	1.0
0.718 ± 7		1	0.22
1.744 ± 7		1	0.73
2.157 ± 6		1	0.44
3.587 ± 6		1	0.09
4.777 ± 5		1	0.09
5.114 ± 5			
5.166 ± 5		1	1.81
5.923 ± 5			
6.028 ± 5			
6.131 ± 5			
6.570 ± 7	30 ± 10		
7.002 ± 10	95 ± 10		
7.475 ± 10			
7.567 ± 10			
7.87 ± 40	240 ± 50		
10.85 ± 100	300 ± 100		
11.52 ± 35	500 ± 100		
12.56 ± 30	100 ± 30		
13.49 ± 50	300 ± 50		
14.4 ± 100	800 ± 200		
(18.2 ± 200)	(1500 ± 300)		

^a See Table 10.21 in (1979AJ01) for references.

require $J^\pi = 3^-$ for $^{10}\text{B}^*(6.13)$. There is substantial interference between levels of opposite parity for the α -particles due to $^{10}\text{B}^*(6.56, 7.00)$: the data are fitted by $J^\pi = 3^+$ for $^{10}\text{B}^*(7.00)$ and $(3, 4)^-$ for $^{10}\text{B}^*(6.56)$ [the $^6\text{Li}(\alpha, \alpha)$ results then require $J^\pi = 4^-$]. See, however, reaction 15, and see (1974AJ01) for the references. See also (1988GOZB; theor.).

$$45. \ ^{11}\text{B}(^7\text{Li}, ^8\text{Li})^{10}\text{B} \quad Q_m = -9.421$$

Angular distributions have been measured at $E(^7\text{Li}) = 34$ MeV involving $^{10}\text{B}^*(0, 0.72, 1.74, 2.15)$ and $^8\text{Li}_{\text{g.s.}}$ (as well as $^8\text{Li}^*(0.98)$ in the case of the $^{10}\text{B}_{\text{g.s.}}$ transition) (1987CO16).

$$46. \text{ (a) } ^{12}\text{C}(\gamma, \text{d})^{10}\text{B} \quad Q_m = -25.1868$$

$$\text{ (b) } ^{12}\text{C}(\gamma, \text{pn})^{10}\text{B} \quad Q_m = -27.4114$$

For reaction (a) see (1986SH1M) and ^{12}C in (1990AJ01). For reaction (b) see ^{12}C in (1985AJ01). See also (1984DO17) and (1984CH1A, 1986GU1G; theor.).

$$47. \ ^{12}\text{C}(\text{n}, \text{t})^{10}\text{B} \quad Q_m = -18.9295$$

See (1985FR07, 1987FR16; $E_n = 319$ to 545 MeV). See also (1986DO12).

$$48. \ ^{12}\text{C}(\pi^\pm, \pi^\pm\text{d})^{10}\text{B} \quad Q_m = -25.1868$$

At $E_{\pi^+} = 180$ MeV and $E_{\pi^-} = 220$ MeV, $^{10}\text{B}^*(0.72, 2.15)$ are populated: see (1984AJ01). At $E_{\pi^+} = 150$ MeV momentum distributions of pions to unresolved states of ^{10}B are reported by (1987HU13).

$$49. \text{ (a) } ^{12}\text{C}(\text{p}, ^3\text{He})^{10}\text{B} \quad Q_m = -19.6933$$

$$\text{ (b) } ^{12}\text{C}(\text{p}, \text{pd})^{10}\text{B} \quad Q_m = -25.1868$$

Angular distributions of ^3He ions have been measured for $E_p = 39.8, 51.9$ and 185 MeV: see (1979AJ01). $^{10}\text{B}^*(0, 0.72, 1.74, 2.15, 3.59, 4.77, 5.16, 5.92, 6.56, 7.50, 8.90)$ are populated. For reaction (b) see (1985DE17; $E_p = 58$ MeV; $^{10}\text{B}^*(0.72, 1.74)$) and (1984AJ01). See also (1986VDZY) and (1986GO28, 1986ZH03, 1987GA08, 1987KW01; theor.).

50. $^{12}\text{C}(\text{d}, \alpha)^{10}\text{B}$ $Q_{\text{m}} = -1.3401$

Alpha groups have been observed to most of the known states of ^{10}B below $E_{\text{x}} = 7.1$ MeV: see Table 10.23 in (1974AJ01). Angular distributions have been measured for $E_{\text{d}} = 5.0$ to 40 MeV: see (1979AJ01). Single-particle S -values are 1.5, 0.5, 0.1, 0.1 and 0.3 for $^{10}\text{B}^*(0, 0.72, 2.15, 3.59, 4.77)$. A study of the $m_{\text{s}} = 0$ yield at $E_{\text{d}} = 14.5$ MeV ($\theta = 0^\circ$) leads to assignments of 3^+ , 2^- and $(3^+, 4^-)$ for $^{10}\text{B}^*(4.77, 5.11, 6.56)$. The population of the isospin-forbidden group to $^{10}\text{B}^*(1.74)$ [α_2] has been studied with E_{d} up to 30 MeV: see ^{14}N in (1986AJ01). See also (1984LOZZ).

51. $^{12}\text{C}(\alpha, ^6\text{Li})^{10}\text{B}$ $Q_{\text{m}} = -23.7118$

Angular distributions have been reported at $E_{\alpha} = 42$ and 46 MeV: see (1979AJ01). At $E_{\alpha} = 65$ MeV, an investigation of the ^6Li breakup shows that $^{10}\text{B}^*(0, 0.72, 2.16, 3.57, 4.77, 5.2, 5.9, 6.0)$ are involved: see (1984AJ01). See also (1987GA20).

52. $^{12}\text{C}(^7\text{Li}, ^9\text{Be})^{10}\text{B}$ $Q_{\text{m}} = -8.492$

At $E(^7\text{Li}) = 78$ MeV angular distributions have been measured to $^{10}\text{B}^*(0, 2.15)$ (1986GLZV; prelim.).

53. (a) $^{12}\text{C}(^{12}\text{C}, ^{14}\text{N})^{10}\text{B}$ $Q_{\text{m}} = -14.9144$
 (b) $^{12}\text{C}(^{14}\text{N}, ^{16}\text{O})^{10}\text{B}$ $Q_{\text{m}} = -4.4505$

Angular distributions (reaction (a)) involving $^{10}\text{B}^*(0, 0.7)$ have been studied at $E(^{12}\text{C}) = 49.0$ to 75.5 and 93.8 MeV. Angular distributions (reaction (b)) involving $^{10}\text{B}^*(0, 0.72, 2.15, 3.59)$ have been measured at $E(^{14}\text{N}) = 53$ MeV and 78.8 MeV (not to $^{10}\text{B}^*(3.59)$): see (1979AJ01, 1984AJ01) for references. See also (1986AR04, 1986CR1A, 1986MOZV).

54. $^{13}\text{C}(\text{p}, \alpha)^{10}\text{B}$ $Q_{\text{m}} = -4.0618$

Angular distributions have been measured at $E_{\text{p}} = 5.8$ to 18 MeV and 43.7 and 50.5 MeV: see (1979AJ01). See also ^{14}N in (1986AJ01) and (1985MAZG; theor.).

55. $^{14}\text{N}(\text{p}, \text{p}\alpha)^{10}\text{B}$ $Q_{\text{m}} = -11.6125$

See (1986VDZY; $E_p = 50$ MeV; prelim.). See also (1986GO28; theor.).

$$56. \text{}^{14}\text{N}(\text{d}, \text{}^6\text{Li})\text{}^{10}\text{B} \quad Q_m = -10.137$$

At $E_d = 80$ MeV angular distributions are reported to $^{10}\text{B}^*(0, 0.72, 2.15, 3.59, 4.8, 6.04, 7.05, 8.68)$: see (1984AJ01).

$$57. \text{}^{16}\text{O}(\text{}^9\text{Be}, \text{}^{15}\text{N})\text{}^{10}\text{B} \quad Q_m = -5.542$$

See (1985WI18).

¹⁰C
(Figs. 3 and 4)

GENERAL: See also (1984AJ01).

Model calculations: (1984SA37, 1987BL18).

Special states: (1986AB10).

Astrophysical questions: (1987RA1D).

Complex reactions involving ¹⁰C: (1983FR1A, 1983OL1A, 1986HA1B, 1987AR19, 1987BEYI, 1987RI03, 1987SN01, 1987TAZU, 1988BEYJ, 1988CA06, 1988KI05, 1988SA19).

Reactions involving pions and other mesons (See also reactions 2 and 4.): (1985LI1E, 1987SI18).

Other topics: (1982KA1D, 1985AN28, 1986YA1F).

Ground-state properties of ¹⁰C: (1983ANZQ, 1985AN28, 1987BL18, 1987SA15).

Mass of ¹⁰C: The threshold energy for the ¹⁰B(p, n)¹⁰C reaction is 4876.90 ± 0.37 keV: then $Q_0 = -4430.17 \pm 0.34$ keV (1984BA12). Using the (1988WA18) masses for ¹⁰B, p and n, the atomic mass excess of ¹⁰C is then 15698.8 ± 0.5 keV. This value does not include a contribution from unpublished work on ¹²C(p, t)¹⁰C quoted in (1984AJ01). However, we adopt the (1988WA18) value: 15699.1 ± 0.3 keV.

$$B(E2)\uparrow \text{ for } ^{10}\text{C}^*(3.35) = (6.2 \pm 1.0) \times 10^{-3} e^2 \cdot \text{b}^2, \\ [Q_0 = 0.25 \pm 0.02 \text{ b}] \text{ (1987RA01).}$$

1. ¹⁰C(β^+)¹⁰B $Q_m = 3.6481$

¹⁰C decays with a half-life of 19.255 ± 0.053 sec to ¹⁰B*(0.7, 1.7): the branching ratios are $(98.53 \pm 0.02)\%$ and $(1.465 \pm 0.014)\%$, respectively: see (1974AJ01). See also reaction 40 in ¹⁰B and (1986CA1L).

2. ⁷Li(³He, π^-)¹⁰C $Q_m = -125.429$

At $E(^3\text{He}) = 235$ MeV ¹⁰C*(3.35) is populated (1984BI08). π^- production in this reaction has also been studied by (1984BR22) At $E(^3\text{He}) = 910$ MeV.

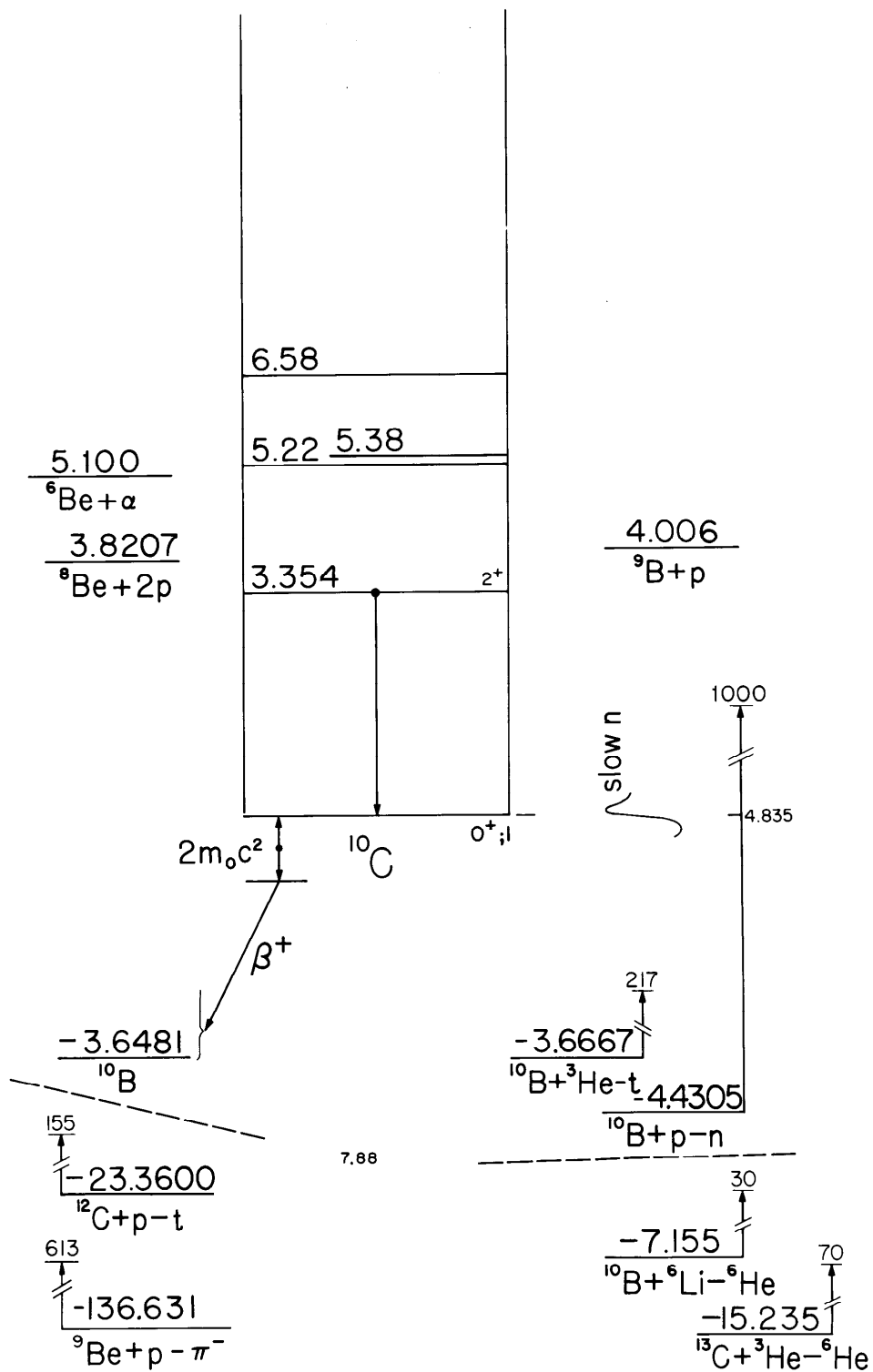

Fig. 3: Energy levels of ^{10}C . For notation see Fig. 1.

Table 10.18: Energy levels of ^{10}C

E_x (MeV \pm keV)	$J^\pi; T$	τ or $\Gamma_{c.m.}$ (keV)	Decay	Reactions
g.s.	$0^+; 1$	$\tau_{1/2} = 19.255 \pm 0.053$ sec	β^+	1, 4, 5, 6, 7, 8
3.3536 ± 0.7	2^+	$\tau_m = 155 \pm 25$ fsec	γ	2, 4, 5, 6, 7, 8
5.22 ± 40	^a	$\Gamma = 225 \pm 45$ keV		4, 5, 6, 7
5.38 ± 70	^a	300 ± 60		4, 5, 6, 7
6.580 ± 20	(2^+)	200 ± 40		4, 6, 7

^a One of these two states is presumably a 2^+ state.

3. ${}^7\text{Li}({}^7\text{Li}, 4n){}^{10}\text{C}$ $Q_m = -18.171$

Tetraneutron (n^4) production has been studied in this and in other reactions involving ^{10}C at $E({}^7\text{Li}) = 82$ MeV ([1987ALZG](#); prelim.): it is not observed.

4. ${}^9\text{Be}(p, \pi^-){}^{10}\text{C}$ $Q_m = -136.631$

Angular distributions of π^- groups have been measured at $E_p = 185$ MeV (to $^{10}\text{C}^*(0, 3.35, 5.28, 6.63)$), at 200 MeV (g.s.), at 800 MeV (to $^{10}\text{C}^*(0, 3.35, 5.3, 6.6)$) [see ([1984AJ01](#))] and at $E_{\bar{p}} = 650$ MeV ([1986HO23](#); $^{10}\text{C}^*(0, 3.35)$; also A_y). A_y measurements have also been reported at $E_{\bar{p}} = 200$ to 250 MeV: see ([1984AJ01](#)).

5. ${}^{10}\text{B}(p, n){}^{10}\text{C}$ $Q_m = -4.4305$

$$Q_0 = -4430.17 \pm 0.34 \text{ keV} \text{ ([1984BA12](#))}$$

The E_x of $^{10}\text{C}^*(3.35) = 3352.7 \pm 1.5$ keV, $\tau_m = 155 \pm 25$ fsec, $\Gamma_\gamma = 4.25 \pm 0.69$ meV. Angular distributions have been measured for the n_0 and n_1 groups and for the neutrons to $^{10}\text{C}^*(5.2 \pm 0.3)$ at $E_p = 30$ and 50 MeV [see ([1974AJ01](#), [1979AJ01](#))] and for the n_0 and n_1 groups at $E_p = 14.0, 14.3$ and 14.6 MeV ([1985SC08](#)) and 15.8 and 18.6 MeV ([1985GU1C](#); prelim.). See also ([1984BA1R](#), [1988KA2E](#)).

6. ${}^{10}\text{B}({}^3\text{He}, t){}^{10}\text{C}$ $Q_m = -3.6667$

Angular distributions have been measured at $E(^3\text{He}) = 14$ MeV and 217 MeV: see (1979AJ01). The latter [to $^{10}\text{C}^*(0, 3.35, 5.6)$] have been compared with microscopic calculations using a central+tensor interaction [$J^\pi = 0^+, 2^+, 2^+$]. Structures have been reported at $E_x = 5.22 \pm 0.04$ [$\Gamma = 225 \pm 45$ keV], 5.38 ± 0.07 [300 ± 60 keV] and 6.580 ± 0.020 MeV [190 ± 35 keV].

$$7. \ ^{12}\text{C}(\text{p}, \text{t})^{10}\text{C} \quad Q_{\text{m}} = -23.3600$$

Angular distributions have been reported at $E_{\text{p}} = 30.0$ to 54.1 MeV and at 80 MeV [see (1974AJ01, 1979AJ01, 1984AJ01)]. $L = 0, 2$ and 2 to $^{10}\text{C}^*(0, 3.35, 5.28)$ thus leading to $0^+, 2^+$ and 2^+ for these states [but note that the “5.28 MeV” state is certainly unresolved]: see reaction 6 and Table 10.18. $^{10}\text{C}^*(6.6)$ is also populated. Two measurements of the excitation energy of $^{10}\text{C}^*(3.4)$ are 3353.5 ± 1.0 keV, 3354.3 ± 1.1 keV: see (1984AJ01) [based on Q_{m}]. See also (1987KW01; theor.).

$$8. \ ^{13}\text{C}(^3\text{He}, ^6\text{He})^{10}\text{C} \quad Q_{\text{m}} = -15.235$$

At $E(^3\text{He}) = 70.3$ MeV the angular distributions of the ^6He ions corresponding to the population of $^{10}\text{C}^*(0, 3.35)$ have been measured. The group to $^{10}\text{C}^*(3.35)$ is much more intense than the ground-state group: see (1979AJ01).

$^{10}\text{N}, ^{10}\text{O}, ^{10}\text{F}, ^{10}\text{Ne}$
(Not illustrated)

Not observed: see (1979AJ01). (1985WA02) suggest 39.7 ± 0.4 MeV for the atomic mass excess of ^{10}N . See also (1982KA1D, 1983ANZQ, 1987BL18, 1987SA15; theor.).

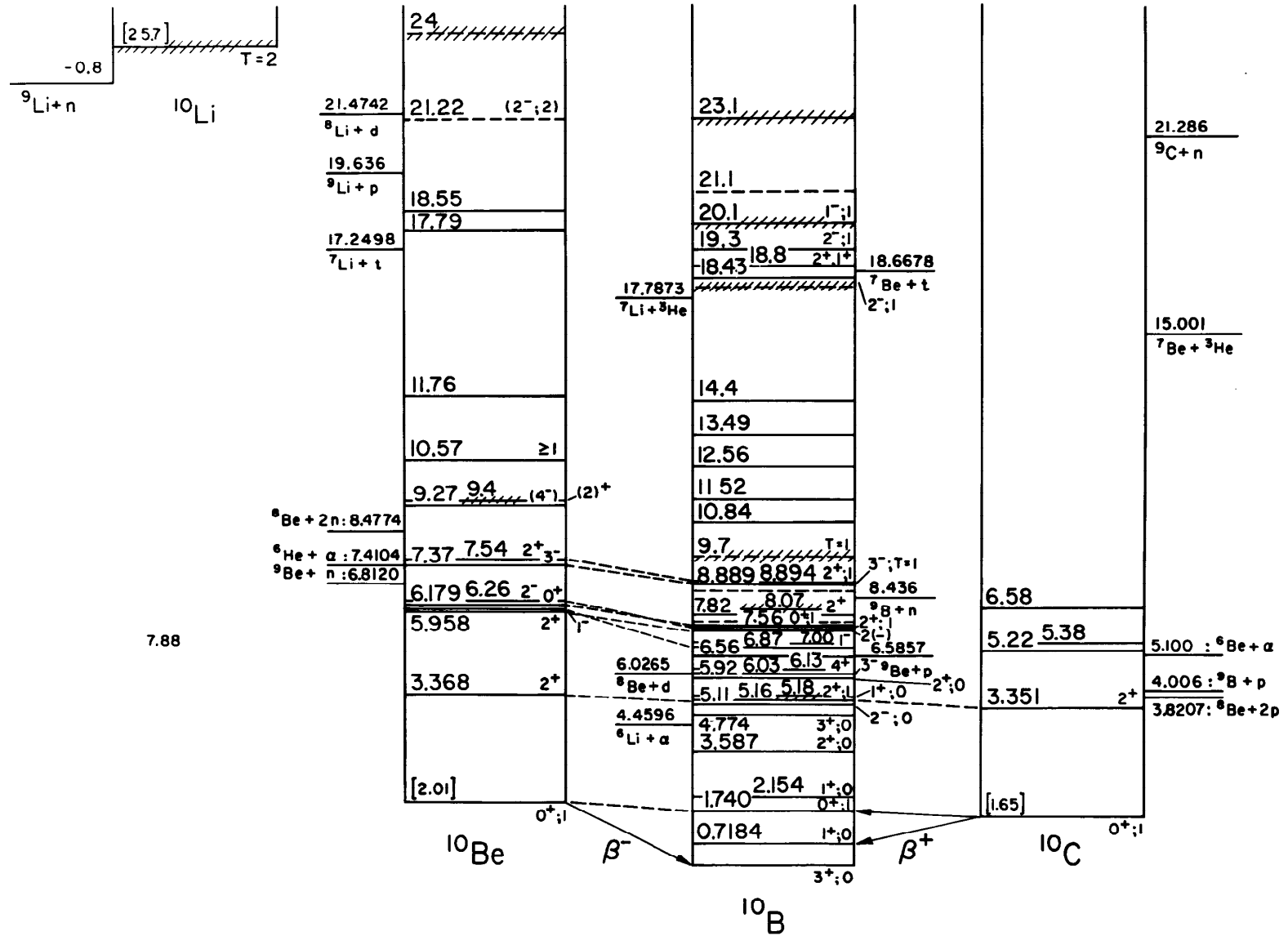

Fig. 4: Isobar diagram, $A = 10$. The diagrams for individual isobars have been shifted vertically to eliminate the neutron-proton mass difference and the Coulomb energy, taken as $E_C = 0.60Z(Z - 1)/A^{1/3}$. Energies in square brackets represent the (approximate) nuclear energy, $E_N = M(Z, A) - ZM(\text{H}) - NM(\text{n}) - E_C$, minus the corresponding quantity for ^{10}B : here M represents the atomic mass excess in MeV. Levels which are presumed to be isospin multiplets are connected by dashed lines.

References

(Closed 1 June 1988)

- 1966FO05 P.D. Forsyth, H.T. Tu and W.F. Hornyak, Nucl. Phys. 82 (1966) 33
- 1966LA04 T. Lauritsen and F. Ajzenberg-Selove, Nucl. Phys. 78 (1966) 1
- 1966WA10 E.K. Warburton, J.W. Olness, K.W. Jones, C. Chasman, R.A. Ristinen and D.H. Wilkinson, Phys. Rev. 148 (1966) 1072
- 1974AJ01 F. Ajzenberg-Selove and T. Lauritsen, Nucl. Phys. A227 (1974) 1
- 1974KE06 K.W. Kemper, S. Cotanch, G.E. Moore, A.W. Obst, R.J. Puigh and R.L. White, Nucl. Phys. A222 (1974) 173
- 1977KI04 A. Kiss, E. Koltay, G. Szabo and L. Vegh, Nucl. Phys. A282 (1977) 44
- 1978LEZA C.M. Lederer, V.S. Shirley, E. Browne, J.M. Dairiki, R.E. Doebler, A.A. Shihab-Eldin, L.J. Jardine, J.K. Tuli and A.B. Buyrn, Table of Isotopes 7th Ed. (1978)
- 1979AJ01 F. Ajzenberg-Selove, Nucl. Phys. A320 (1979) 1
- 1979KE08 J. Keinonen and A. Anttila, Nucl. Phys. A330 (1979) 397
- 1979SP01 R.H. Spear, Z.E. Switkowski, D.L. Kennedy and J.C.P. Heggie, Nucl. Phys. A318 (1979) 21
- 1980AJ01 F. Ajzenberg-Selove and C.L. Busch, Nucl. Phys. A336 (1980) 1
- 1980BL02 L. Bland and H.T. Fortune, Phys. Rev. C21 (1980) 11
- 1980HA33 M.N. Harakeh, J. Van Popta, A. Saha and R.H. Siemssen, Nucl. Phys. A344 (1980) 15
- 1980MA33 G. Mack, R.C. Byrd, P.W. Lisowski and R.L. Walter, Nucl. Phys. A345 (1980) 241
- 1981MUZQ S.F. Mughabghab, M. Divadeenam and N.E. Holden, Neutron Cross Sections Part A, Z=1-60 (1981)
- 1982AL08 D.V. Aleksandrov, Yu.A. Glukhov, A.S. Demyanova, V.I. Dukhanov, I.B. Mazurov, B.G. Novatsky, A.A. Ogloblin, S.B. Sakuta and D.N. Stepanov, Yad. Fiz. 35 (1982) 277; Sov. J. Nucl. Phys. 35 (1982) 158
- 1982AL33 D.V. Aleksandrov, Yu.A. Glukhov, A.S. Demyanova, V.I. Dukhanov, I.B. Mazurov, B.G. Novatsky, A.A. Ogloblin, S.B. Sakuta and D.N. Stepanov, Yad. Fiz. 36 (1982) 1351; Sov. J. Nucl. Phys. 36 (1982) 783
- 1982AU1A Audouze and Reeves, Essays in Nucl. Astrophys. (1982) 355
- 1982BA1D C.A. Barnes, Essays in Nucl. Astrophys. (1982) 193

- 1982BA78 V.N. Baturin, V.V. Vikhrov, M.M. Makarov, V.V. Nelyubin, A.A. Naberezhnov, V.V. Sulimov and L.N. Uvarov, *Pisma Zh. Eksp. Teor. Fiz.* 36 (1982) 370; *JETP Lett.* 36 (1982) 448
- 1982BE1D A.M. Bernstein, *Proc. Int. School of Intermediate Energy Nucl. Phys., Verona, Italy, July 1981*; Eds., R. Bergere, S. Costa and C. Schaerf (1982) 125
- 1982BR1A Braun and Vechernin, *Sov. J. Nucl. Phys.* 36 (1982) 357
- 1982CA1A Cameron, *Essays in Nucl. Astrophys.* (1982) 23
- 1982KA1D K. Kar and J.C. Parikh, *Pramana* 19 (1982) 555
- 1982WA1A W.W. Wang, Y.S. Zhang and R.L. Wang, *Kexue Tongbao* 27 (1982) 711
- 1983AB1A Abramovitch et al., in *Moscow* (1983) 362
- 1983AI01 O. Aizawa, T. Matsumoto and H. Kadotani, *J. Nucl. Sci. Tech.* 20 (1983) 354
- 1983AL10 M. Allab, A. Boucenna and M. Haddad, *J. Phys. (Paris)* 44 (1983) 579
- 1983AL20 D.V. Aleksandrov, E.A. Ganza, Yu.A. Glukhov, V.I. Dukhanov, I.B. Mazurov, B.G. Novatsky, A.A. Ogloblin, D.N. Stepanov, V.V. Paramonov and A.G. Trunov, *Yad. Fiz.* 37 (1983) 797; *Sov. J. Nucl. Phys.* 37 (1983) 474
- 1983AM1A G. Amsel and J.A. Davies, *Nucl. Instrum. Meth. Phys. Res.* 218 (1983) 177
- 1983AN1D Antolkovic et al., in *Florence* (1983) 438
- 1983AN1F L. Antonuk, G. Blanpied, D. Bovet, E. Bovet, Y. de Coulon, J.P. Egger, F. Goetz, P. Gretillat, C. Lunke, C. Perrin et al., *Sin Newsl.* 15 (1983) 40
- 1983ANZQ Y. Ando, M. Uno and M. Yamada, *JAERI-M-83-025* (1983)
- 1983BA1D H. Bando, *Prog. Theor. Phys.* 69 (1983) 1731
- 1983BA71 C.J. Batty, *Nucl. Phys.* A411 (1983) 399
- 1983BI13 J.R. Birkelund and J.R. Juizenga, *Ann. Rev. Nucl. Part. Sci.* 33 (1983) 265
- 1983BI1C P.G. Bizzeti, *Riv. Nuovo Cim.* 6 (1983) 1
- 1983BO1C Z.T. Body, F. Cserpak, J. Csikai, S. Sudar and K. Mihaly, *Proc. Int. Conf. on Nucl. Data for Sci. and Tech., Antwerp, Belgium, 6-10 Sept. 1982* (1983) 368
- 1983BY01 R.C. Byrd, C.E. Floyd, P.P. Guss, K. Murphy and R.L. Walter, *Nucl. Phys.* A399 (1983) 94
- 1983BY02 R.C. Byrd, P.W. Lisowski, W. Tornow and R.L. Walter, *Nucl. Phys.* A404 (1983) 29
- 1983CE1A Cereda, de Leo, Micheletti and Pignanelli, in *Florence* (1983) 234
- 1983DA10 B. Dasmahapatra, B. Cujec and F. Lahlou, *Can. J. Phys.* 61 (1983) 657
- 1983DA20 B. Dasmahapatra, B. Cujec and F. Lahlou, *Nucl. Phys.* A408 (1983) 192
- 1983DA22 J.H. Dave and C.R. Gould, *Phys. Rev.* C28 (1983) 2212

- 1983DE26 P.A. De Young, J.J. Kolata, L.J. Satkowiak and M.A. Xapsos, Phys. Rev. C28 (1983) 692
- 1983DU13 G.G. Dussel, A.O. Gattone and E.E. Maqueda, Phys. Rev. Lett. 51 (1983) 2366
- 1983EN04 Y.M. Engel and R.D. Levine, Phys. Rev. C28 (1983) 2321
- 1983FA1B Farwell et al., in Florence (1983) 752
- 1983FE07 V.N. Fetisov, L. Majling, J. Zofka and R.A. Eramzhyan, Z. Phys. A314 (1983) 239
- 1983FR1A W.A. Friedman and W.G. Lynch, Phys. Rev. C28 (1983) 950
- 1983GE12 P.M. Gensini, Lett. Nuovo Cim. 38 (1983) 469
- 1983GE13 P.M. Gensini, Lett. Nuovo Cim. 38 (1983) 620
- 1983GE1C P.M. Gensini, Nuovo Cim A78 (1983) 471
- 1983GM1A M. Gmitro, H.R. Kissener, P. Truol and R.A. Eramzhyan, Fiz. Elem. Chastits At. Yadra 14 (1983) 773; Sov. J. Part. Nucl. 14 (1983) 323
- 1983GO13 J. Gomez del Campo and G.R. Satchler, Phys. Rev. C28 (1983) 952
- 1983GO1H C.R. Gould, J. Dave and R.L. Walter, Proc. Int. Conf. on Nucl. Data for Sci. and Tech., Antwerp, Belgium, 6-10 Sept. 1982 (1983) 766
- 1983GO27 V.G. Gonchar and V.V. Tokarevsky, Izv. Akad. Nauk. SSSR Ser. Fiz. 47 (1983) 2156; Bull. Acad. Sci. USSR Phys. Ser. 47 (1983) 69
- 1983GO28 A.N. Goltsov and N.G. Goncharova, Yad. Fiz. 38 (1983) 1410; Sov. J. Nucl. Phys. 38 (1983) 857
- 1983GU1A C. Guet, Nucl. Phys. A400 (1983) 191
- 1983HA1E Haider and Malik, in Florence (1983) 548
- 1983KA37 S.G. Kadmskyii and Yu.L. Ratis, Izv. Akad. Nauk. SSSR Ser. Fiz. 47 (1983) 2254; Bull. Acad. Sci. USSR Phys. Ser. 47 (1983) 162
- 1983KE11 T.J. Kennett, W.V. Prestwich, R.J. Tervo and J.S. Tsai, Nucl. Instrum. Meth. Phys. Res. 215 (1983) 159
- 1983KO1F S. Komoda and T. Sekiya, Atomkernenerg. Kerntech. 42 (1983) 101
- 1983KU1C Kutschera, Radiocarbon 25 (1983) 677
- 1983LE17 P.M. Lewis, O. Karban, J.M. Barnwell, J.D. Brown, P.V. Drumm, J.M. Nelson and S. Roman, Nucl. Phys. A404 (1983) 205
- 1983LI1A Litherland, Proc. Int. Conf. on Nucl. Phys., Florence, Aug.-Sept. 1983; Eds., P. Blasi and R.A. Riccii; Vol.2 (1983) 697
- 1983MA40 S. Maleki, Nucl. Phys. A403 (1983) 607
- 1983MA53 J.F. Mateja, J. Garman and A.D. Frawley, Phys. Rev. C28 (1983) 1579
- 1983MI1E K. Miyahara, K. Ikeda and H. Bando, Prog. Theor. Phys. 69 (1983) 1717

- 1983NA08 M.N. Namboodiri, R.K. Choudhury, J.B. Natowitz, K. Hagel, L. Adler, P.L. Gonthier, H. Simon, S. Kniffen, R. Patton, E. Tomasi et al., Phys. Rev. C28 (1983) 460
- 1983NE1A Nelson et al., Radiocarbon 25 (1983) 693
- 1983OL1A D.L. Olson, B.L. Berman, D.E. Greiner, H.H. Heckman, P.J. Lindstrom and H.J. Crawford, Phys. Rev. C28 (1983) 1602
- 1983PO1A Poenaru, Ivascu and Sandulescu, in Florence (1983) 662
- 1983PO1D Povh, Proc. Int. Conf. on Nucl. Phys., Florence, Aug.-Sept. 1983; Eds., P. Blasi and R.A. Ricci; Vol. 2 (1983) 455
- 1983RO22 S. Roman, O. Karban, M. Barnwell, J.D. Brown, P.V. Drumm, P.M. Lewis and J.M. Nelson, Phys. Rev. C28 (1983) 2515
- 1983SH1E Y.-J. Shi and F. Zhuang, Phys. Energ. Fortis Phys. Nucl. 7 (1983) 605
- 1983SH1G Sharma et al., Proc. Indian Acad. Sci. 92 (1983) 1
- 1983SH1J K. Shibata and S. Shirato, J. Phys. Soc. Jpn. 52 (1983) 3748
- 1983SH38 Y.-J. Shi, Phys. Rev. C28 (1983) 2452
- 1983SR01 J. Sromicki, M. Hugi, J. Lang, R. Muller, E. Ungricht, L. Jarczyk, B. Kamys, A. Magiera, Z. Rudy, A. Strzalkowski et al., Nucl. Phys. A406 (1983) 390
- 1983TA17 F. Tancu, M.T. Magda, S. Dima, M. Macovei, E. Ivanov, R. Dumitrescu and C. Stan-Sion, Rev. Roum. Phys. 28 (1983) 857
- 1983TU1A Tuniz et al., in Florence (1983) 751
- 1983VA31 A.G.M. van Hees and P.W.M. Glaudemans, Z. Phys. A314 (1983) 323
- 1983VE03 W.J. Vermeer, R.K. Bhalla and A.R. Poletti, Phys. Rev. C28 (1983) 432
- 1983WI1A Wilczynski, Proc. Int. Conf. on Nucl. Phys., Florence, Aug.-Sept. 1983; Eds., P. Blasi and R.A. Ricci; Vol. 2 (1983) 305
- 1983ZIZZ K.O.H. Ziock, J. Boswell, J. Hurd, R.C. Minehart, Y. Tzeng and H.J. Ziock, Bull. Amer. Phys. Soc. 28 (1983) 671, BG4
- 1984AJ01 F. Ajzenberg-Selove, Nucl. Phys. A413 (1984) 1
- 1984AL22 A.S. Alimov, V.I. Mokeev, E.S. Omarov and I.M. Piskarev, Yad. Fiz. 40 (1984) 301; Sov. J. Nucl. Phys. 40 (1984) 190
- 1984AN16 Yu.P. Antufyev, A.S. Deineko, I.I. Zalyubovsky, V.D. Sarana, V.E. Storizhko, A.I. Tutubalin, C. Hategan and N.A. Schliakhov, Yad. Fiz. 40 (1984) 53; Sov. J. Nucl. Phys. 40 (1984) 35
- 1984BA12 P.H. Barker and R.E. White, Phys. Rev. C29 (1984) 1530
- 1984BA1L Yu.D. Bayukov, V.B. Gavrillov, N.A. Goryainov, Yu.G. Grishuk, O.B. Gushchin, P.V. Degtyarenko, N.L. Kornienko, G.A. Leksin, V.B. Fedorov, B.B. Shvartsman et al., Yad. Fiz. 39 (1984) 1482; Sov. J. Nucl. Phys. 39 (1984) 938

- 1984BA1R V.N. Baturin, A.V. Khanzadeev, V.P. Koptev, E.M. Maev, M.M. Makarov, V.V. Nelyubin, G.V. Shcherbakov and V.V. Sulimov, in *Panic* (1984) I11
- 1984BA1U Bayukov et al., in *Panic* (1984) 125
- 1984BE1C Belozarov et al., in *Alma Ata* (1984) 379
- 1984BE1F Beer, *Bull. Amer. Phys. Soc.* 29 (1984) 1094
- 1984BE1H J. Beer, M. Andree, H. Oeschger, U. Siegenthaler, G. Bonani, H. Hofmann, E. Morenzoni, M. Nessi, M. Suter, W. Wolfli, et al., *Nucl. Instrum. Meth. Phys. Res.* B233 (1984) 380
- 1984BI08 L. Bimbot, T. Hennino, J.C. Jourdain, Y. Le Bornec, F. Reide, N. Willis and J.F. Germond, *Phys. Rev.* C30 (1984) 739
- 1984BLZY K.I. Blomqvist, A.M. Bernstein, J. Comuzzi, J.A. Nelson, B.H. Cottman, K. Min, P. Stoler, P.K. Teng, E.J. Winhold, M. Yamazaki et al., *Bull. Amer. Phys. Soc.* 29 (1984) 708, FI9
- 1984BO1D A.R. Bodmer, Q.N. Usmani and J. Carlson, *Nucl. Phys.* A422 (1984) 510
- 1984BO1E D. Bourles, G.M. Raisbeck, F. Yiou, J.M. Loiseaux, M. Lieuvain, J. Klein and R. Middleton, *Nucl. Instrum. Meth. Phys. Res.* B233 (1984) 365
- 1984BO1G A.R. Bodmer, *AIP Conf. Proc.* 123 (1984) 806
- 1984BO1H L.N. Bogdanova and V.E. Markushin, *Fiz. Elem. Chastits At. Yadra* 15 (1984) 808; *Sov. J. Part. Nucl.* 15 (1984) 361
- 1984BR22 T. Bressani, E. Chiavassa, S. Costa, G. Dellacasa, N. De Marco, M. Gallio, A. Musso, E. Aslanides, G. Bergdolt, P. Fassnacht et al., *Phys. Rev.* C30 (1984) 1745
- 1984BR25 B.A. Brown, C.R. Bronk and P.E. Hodgson, *J. Phys. (London)* G10 (1984) 1683
- 1984BY03 R.C. Byrd, C.E. Floyd, K. Murphy, P.P. Guss and R.L. Walter, *Nucl. Phys.* A427 (1984) 36
- 1984CH1A Cherkasov, in *Alma Ata* (1984) 371
- 1984CH1G H.Z. Chen, F. Zhuang, X.J. Shi and X.N. Jin, *Chin. J. Nucl. Phys.* 6 (1984) 303
- 1984CH1H R.E. Chrien, *AIP Conf. Proc.* 123 (1984) 841
- 1984CO1D P. Couvert, *AIP Conf. Proc.* 123 (1984) 689
- 1984DE46 A.S. Deineko, I.I. Zalyubovsky, V.D. Sarana, A.I. Tutubalin and N.A. Shlyakhov, *Izv. Akad. Nauk. SSSR Ser. Fiz.* 48 (1984) 1000; *Bull. Acad. Sci. USSR Phys. Ser.* 48 (1984) 163
- 1984DE53 P. De Bievre, M. Gallet, N.E. Holden and I.L. Barnes, *J. Phys. Chem. Ref. Data* 13 (1984) 809
- 1984DEZX L.C. Dennis and J.S. Hanspal, *Bull. Amer. Phys. Soc.* 29 (1984) 1047, DB3
- 1984DO17 I.V. Dogyust, V.I. Voloshchuk, V.V. Kirichenko and A.F. Khodyachikh, *Yad. Fiz.* 40 (1984) 1382; *Sov. J. Nucl. Phys.* 40 (1984) 878

- 1984DO1B D.J. Donahue, A.J.T. Jull and T.H. Zabel, Nucl. Instrum. Meth. Phys. Res. B233 (1984) 162
- 1984DO20 T.W. Donnelly and I. Sick, Rev. Mod. Phys. 56 (1984) 461
- 1984DZ1A R.I. Dzhibuti and Sh.M. Tsiklauri, Yad. Fiz. 39 (1984) 1115; Sov. J. Nucl. Phys. 39 (1984) 704
- 1984EL05 R.J. Ellis, K.S. Sharma, R.C. Barber, S.R. Loewen and H.E. Duckworth, Phys. Lett. B141 (1984) 306
- 1984EL1B D. Elmore, P.W. Kubick, L.E. Tubbs, H.E. Gove, R. Teng, T. Hemmick, B. Chrnyk and N. Conard, Nucl. Instrum. Meth. Phys. Res. B233 (1984) 109
- 1984EL1C D. Elmore, N. Conrad, P.W. Kubik and J. Fabryka-Martin, Nucl. Instrum. Meth. Phys. Res. B233 (1984) 233
- 1984EN1A P. Englert, S. Theis, R. Michel, C. Tuniz, R.K. Moniot, S. Vajda, T.H. Kruse, D.K. Pal and G.F. Herzog, Nucl. Instrum. Meth. Phys. Res. B233 (1984) 415
- 1984ER1A Eramzhyan, Majling, Zofka and Fetisov, in Panic (1984) M21
- 1984ER1B R.A. Eramzhyan, M. Gmitro, T.D. Kaipov, S.S. Kamalov and R. Mach, Proc. Wrkshp. on Perspectives in Nucl. Phys. at Intermediate Energ., Trieste, Italy, 10-14 Oct. 1983 (1984) 195
- 1984FR13 H. Friedrich, Phys. Lett. B146 (1984) 135
- 1984FR1A P. Frobrich, Phys. Rept. 116 (1984) 337
- 1984GO05 J. Gomez del Campo, J.A. Biggerstaff, R.A. Dayras, D. Shapira, A.H. Snell, P.H. Stelson and R.G. Stokstad, Phys. Rev. C29 (1984) 1722
- 1984GR08 R.E.L. Green, R.G. Korteling and K.P. Jackson, Phys. Rev. C29 (1984) 1806
- 1984HA43 Q. Haider and B. Cujec, Nucl. Phys. A429 (1984) 116
- 1984HA53 Q. Haider and F.B. Malik, At. Data Nucl. Data Tables 31 (1984) 185
- 1984HAZK J.S. Hanspal, L.C. Dennis, A.D. Frawley and R.A. Parker, Bull. Amer. Phys. Soc. 29 (1984) 1047, DB2
- 1984HE1B R.E.M. Hedges, Nucl. Instrum. Meth. Phys. Res. 220 (1984) 211
- 1984HE1C W. Henning, Nuovo Cim. A81 (1984) 191
- 1984HI1A A.S. Hirsch, A. Bujak, J.E. Finn, L.J. Gutay, R.W. Minich, N.T. Porile, R.P. Scharenberg and B.C. Stringfellow, Phys. Rev. C29 (1984) 508
- 1984HO1E H. Hofmann, G. Bonani, E. Morenzoni, M. Nessi, M. Suter and W. Wolfli, Nucl. Instrum. Meth. Phys. Res. B233 (1984) 254
- 1984HO23 H. Homeyer, M. Burgel, Ch. Egelhaaf, H. Fuchs and G. Thoma, Z. Phys. A319 (1984) 143

- 1984IM1A M. Imamura, Y. Hashimoto, K. Yoshida, I. Yamane, H. Yamashita, T. Inoue, S. Tanaka, H. Nagai, M. Honda, K. Kobayashi et al., Nucl. Instrum. Meth. Phys. Res. B233 (1984) 211
- 1984IN03 M. Inoue and S.E. Koonin, Phys. Rev. C30 (1984) 175
- 1984KA1C Kaipov and Kamalov, in Alma Ata (1984) 405
- 1984KL1A J. Klein and R. Middleton, Nucl. Instrum. Meth. Phys. Res. B233 (1984) 129
- 1984KO1F Kobayashi and Ikeda, in Panic (1984) M1
- 1984KO24 K. Koshigiri, H. Ohtsubo and M. Morita, Prog. Theor. Phys. 71 (1984) 1293
- 1984LOZZ M.M. Lowry and R.T. Kouzes, Bull. Amer. Phys. Soc. 29 (1984) 629, AG6
- 1984MA1F May et al., in Panic (1984) M3
- 1984MA1K A. Mangini, M. Segl, G. Bonani, H.J. Hofmann, E. Morenzoni, M. Nessi, M. Suter, W. Wolfli and K.K. Turekian, Nucl. Instrum. Meth. Phys. Res. B233 (1984) 353
- 1984MAZT F.B. Malik and Q. Haider, Bull. Amer. Phys. Soc. 29 (1984) 1047, DB1
- 1984ME11 C.R. Meitzler, A.E. Khalil, A.B. Robbins and G.M. Temmer, Phys. Rev. C30 (1984) 1105
- 1984MI1C Millener, Gal, Dover and Dalitz, in Panic (1984) M7
- 1984MI1D R. Middleton, J. Klein, L. Brown and F. Tera, Nucl. Instrum. Meth. Phys. Res. B233 (1984) 511
- 1984MI1E D.J. Millener, AIP Conf. Proc. 123 (1984) 850
- 1984MIZM I.A. Mitropolsky and E.F. Khefter, in Alma Ata (1984) 241
- 1984NA07 J. Napolitano and S.J. Freedman, Nucl. Phys. A417 (1984) 289
- 1984NE1C D.E. Nelson, J.R. Southon, J.S. Vogel, R.G. Korteling and T.L. Ku, Nucl. Instrum. Meth. Phys. Res. B233 (1984) 139
- 1984NE1D G. Newkirk, Jr., Nucl. Instrum. Meth. Phys. Res. B233 (1984) 404
- 1984NE1E M. Nessi, E. Morenzoni, M. Suter, G. Bonani, H.J. Hofmann, C. Stoller and W. Wolfli, Nucl. Instrum. Meth. Phys. Res. B233 (1984) 238
- 1984NI12 H. Nishioka, J. Phys. (London) G10 (1984) 1713
- 1984PA1E G. Paic, B. Antolkovic and K. Kadija, Fizika 16 (1984) 37
- 1984PO11 D.N. Poenaru and M. Ivascu, J. Phys. (Paris) 45 (1984) 1099
- 1984PO1C G. Possnert, Nucl. Instrum. Meth. Phys. Res. B233 (1984) 159
- 1984RA1D G.M. Raisbeck, F. Yiou, D. Bourles, J. Lestringuez and D. Deboffle, Nucl. Instrum. Meth. Phys. Res. B233 (1984) 175
- 1984RE14 S.M. Read and V.E. Viola, Jr., At. Data Nucl. Data Tables 31 (1984) 359

- 1984SA1D R. Sarafin, G. Bonani, U. Herpers, P. Signer, H. Hofmann, M. Nessi, E. Morenzoni, M. Suter, R. Wieler and W. Wolfli, Nucl. Instrum. Meth. Phys. Res. B233 (1984) 411
- 1984SA37 M. Sakai, At. Data Nucl. Data Tables 31 (1984) 399
- 1984SE1B M. Segl, A. Mangini, G. Bonani, H.J. Hofmann, M. Nessi, M. Suter, W. Wolfli, G. Friedrich, W.L. Pluger, A. Wiechowski et al., Nature 309 (1984) 540
- 1984SE1D M. Segl, A. Magini, G. Bonani, H.J. Hofmann, E. Morenzoni, M. Nessi, M. Suter and W. Wolfli, Nucl. Instrum. Meth. Phys. Res. B233 (1984) 359
- 1984SH1J M. Shoeb and M.Z. Khan, J. Phys. (London) G10 (1984) 1047
- 1984SH1K Sherif, in Panic (1984) I35
- 1984SH1L P. Sharma and B.L.K. Somavajulu, Isot. Geosci. 2 (1984) 89
- 1984SH1P K. Shibata and K. Ioki, JAERI-M-84-165 (1984)
- 1984SH1R K. Shibata, JAERI-M-84-226 (1984)
- 1984SO1A J.R. Southon, J.S. Vogel, G. Richards and D.E. Nelson, Nucl. Instrum. Meth. Phys. Res. 219 (1984) 435
- 1984SO1B B.L.K. Somavajulu, P. Sharma, J. Beer, G. Bonani, H.-J. Hofmann, E. Morenzoni, M. Nessi, M. Suter and W. Wolfli, Nucl. Instrum. Meth. Phys. Res. B233 (1984) 398
- 1984SP1B R.J. Sparks, G. Wallace, C.M. Bartle, G.E. Coote, R.G. Ditchburn, D.C. Lowe, W.J. McCabe and K.P. Pohl, Nucl. Instrum. Meth. Phys. Res. B233 (1984) 155
- 1984ST1B R.G. Stokstad, Comments on Nucl. Part. Phys. 13 (1984) 231
- 1984SU1B Suter et al., Bull. Amer. Phys. Soc. 29 (1984) 1115
- 1984TE1A Teh et al., Bull. Amer. Phys. Soc. 29 (1984) 1502
- 1984TR03 R.P. Trelle, J. Birkhauser, F. Hinterberger, S. Kuhn, D. Prasuhn and P. von Rossen, Phys. Lett. B134 (1984) 34
- 1984TR1C J.W. Truran, Ann. Rev. Nucl. Part. Sci. 34 (1984) 53
- 1984TU02 M. Turk and B. Antolkovic, Nucl. Phys. A431 (1984) 381
- 1984TU1A C. Tuniz, D.K. Pal, R.K. Moniot, W. Savin, T. Kruse and G.F. Herzog, Nuovo Cim. A81 (1984) 201
- 1984TU1C C. Tuniz, R.K. Moniot, W. Savin, S. Vajda, T.H. Kruse, D.K. Pal, G.F. Herzog and M.J. Carr, Nucl. Instrum. Meth. Phys. Res. B233 (1984) 321
- 1984VA06 A.G.M. van Hees and P.W.M. Glaudemans, Z. Phys. A315 (1984) 223
- 1984VA07 O.I. Vasileva, V.M. Lebedev, A.V. Spassky, I.B. Teplov and L.N. Fateeva, Izv. Akad. Nauk. SSSR Ser. Fiz. 48 (1984) 155; Bull. Acad. Sci. USSR Phys. Ser. 48 (1984) 157
- 1984VA1D K. van der Borg, C. Alderliesten, H. Haitjema, G. Hut and N.A. van Zwol, Nucl. Instrum. Meth. Phys. Res. B233 (1984) 150

- 1984WA21 J.W. Watson, P.J. Pella, M. Ahmad, B.S. Flanders, N.S. Chant, P.G. Roos, D.W. Devins and D.L. Friesel, *J. Phys. (Paris)* 45 (1984) 91
- 1984YA1A J. Yang, M.S. Turner, G. Steigman, D.N. Schramm and K.A. Olive, *Astrophys. J.* 281 (1984) 493
- 1984ZH1B F. Zhuang, H.-Z. Chen and X.-N. Jin, *Phys. Energ. Fortis Phys. Nucl.* 8 (1984) 215
- 1984ZU01 R.Ya. Zulkarneev and R.Kh. Kutuev, *Yad. Fiz.* 39 (1984) 785; *Sov. J. Nucl. Phys.* 39 (1984) 495
- 1984ZW1A Zwarts, Unpublished Ph.D. Thesis, Utrecht Univ. (1984)
- 1985AH1A I. Ahmad, M. Mian and M.Z. Rahman Khan, *Phys. Rev.* C31 (1985) 1590
- 1985AJ01 F. Ajzenberg-Selove, *Nucl. Phys.* A433 (1985) 1; Erratum *Nucl. Phys.* A449 (1986) 155.
- 1985AL1G Aleksandrov et al., *Questions in At. Phys. and in Tech., USSR* (1985) 3
- 1985AN28 M.S. Antony, J. Britz, J.B. Bueb and A. Pape, *At. Data Nucl. Data Tables* 33 (1985) 447
- 1985BA1T Barnes, *Lecture Notes in Phys.* 219 (1985) 70
- 1985BE13 R.B. Begzhanov, E.A. Romanovsky, Yu.I. Denisov, A.M. Mukhamedzhanov, I.R. Gulamov, T. Iskhakov, G.K. Ni, R. Yarmukhamedov, G.S. Valiev and V.A. Stepanenko, *Izv. Akad. Nauk. SSSR Ser. Fiz.* 49 (1985) 111; *Bull. Acad. Sci. USSR Phys. Ser.* 49 (1985) 117
- 1985BE1A M. Beckerman, *Phys. Rept.* 129 (1985) 145
- 1985BE1D J. Beer, H. Oeschger, R.C. Finkel, G.C. Castagnoli, G. Bonino, M.R. Attolini and M. Galli, *Nucl. Instrum. Meth. Phys. Res.* B10-11 (1985) 415
- 1985BE1K A.M. Bernstein, *AIP Conf. Proc.* 133 (1985) 271
- 1985BE30 S.L. Belostotsky, S.S. Volkov, A.A. Vorobyev, Yu.V. Dotsenko, L.G. Kudin, N.P. Kuropatkin, O.V. Miklukho, V.N. Nikulin and O.E. Prokofyev, *Yad. Fiz.* 41 (1985) 1425; *Sov. J. Nucl. Phys.* 41 (1985) 903
- 1985BO1D Body and Mihaly, *INDC (HUN)-22/L* (1985)
- 1985CA41 G.R. Caughlan, W. A. Fowler, M.J. Harris and B.A. Zimmerman, *At. Data Nucl. Data Tables* 32 (1985) 197
- 1985CU1A B. Cujec, *Lecture Notes in Phys.* 219 (1985) 108
- 1985DE17 E. Descroix, M. Bedjidian, J.Y. Grossiord, A. Guichard, M. Gusakov, M. Jacquin, J.R. Pizzi and G. Bagieu, *Nucl. Phys.* A438 (1985) 112
- 1985DE19 A.S. Deineko, C. Hategan and N.A. Shliakhov, *Rev. Roum. Phys.* 30 (1985) 103
- 1985DEZY J. Derderian, R.E. Chrien, M. May, P. Pile, R. Sutter, P. Barnes, R. Eisenstein, G. Franklin, R. Grace, D. Marlow et al., *Bull. Amer. Phys. Soc.* 30 (1985) 793, IF2

- 1985DO16 Yu.V. Dotsenko and V.E. Starodubsky, *Yad. Fiz.* 42 (1985) 107; *Sov. J. Nucl. Phys.* 42 (1985) 66.
- 1985DY03 R. Dymarz, *Phys. Lett.* B155 (1985) 5
- 1985FR07 J. Franz, E. Rossle, C. Sauerwein, H. Schmitt, H.L. Woolverton, J. Ero, Z. Fodor, J. Kecskemeti, P. Koncz, Zs. Kovacs et al., *Phys. Lett.* B153 (1985) 382
- 1985GLZZ C.W. Glover, E.E. Gross, A.W. Carpenter, J.A. Carr, R.J. Philpott, F. Petrovich, P. Schwandt, W.W. Jacobs and H.O. Meyer, *Bull. Amer. Phys. Soc.* 30 (1985) 701, AE9
- 1985GO1A N.G. Goncharova, H.-R. Kissener and R.A. Eramzhyan, *Fiz. Elem. Chastits At. Yadra* 16 (1985) 773; *Sov. J. Part. Nucl.* 16 (1985) 337
- 1985GU1C Gulyamov et al., in *Leningrad* (1985) 291
- 1985GU1J K.K. Gudima and V.D. Toneev, *Yad. Fiz.* 42 (1985) 645; *Sov. J. Nucl. Phys.* 42 (1985) 409
- 1985GUZQ M.G. Gulyamov, M.A. Kayumov, K. Khamidova, F. Kadirov and M.Yu. Tashmetov, in *Leningrad* (1985) 321
- 1985HA18 S.S. Hanna and J.W. Hugg, *Hyperfine Interactions* 21 (1985) 59
- 1985HA1J H.J. Hauser, T. Rohwer, F. Hoyler, G. Staudt, S. Abd el-Kariem, P. Grasshoff, H.V. Klapdor, A. Korber, W. Leitner, V. Rapp et al., *AIP Conf. Proc.* 125 (1985) 701
- 1985HU04 M.S. Hussein, B.V. Carlson, O. Civitarese and A. Szanto De Toledo, *Phys. Rev. Lett.* 54 (1985) 2659
- 1985IK1A K. Ikeda, H. Bando and T. Motoba, *Prog. Theor. Phys. Suppl.* 81 (1985) 147
- 1985IM1A N. Imanishi, T. Furuya, I. Fujiwara, A. Shinohara, H. Kaji and S. Iwata, *Phys. Rev.* A32 (1985) 2584
- 1985JA09 L. Jarczyk, B. Kamys, A. Magiera, A. Strzalkowski, A. Szczurek, K. Bodek, M. Hugi, J. Lang, R. Muller and E. Ungricht, *J. Phys. (London)* G11 (1985) 843
- 1985JA12 L. Jarczyk, B. Kamys, Z. Rudy, A. Strzalkowski, B. Styczen, G.P.A. Berg, A. Magiera, J. Meissburger, W. Oelert, P. von Rossen et al., *Z. Phys.* A322 (1985) 221
- 1985JA18 B.V. Jacak, D. Fox and G.D. Westfall, *Phys. Rev.* C31 (1985) 704
- 1985KAZQ S.G. Kadenskii, S.D. Kurgalin and Yu.M. Chuvilskii, in *Leningrad* (1985) 438
- 1985KI1B A.Z. Kiss, E. Koltay, B. Nyako, E. Somorjai, A. Anttila and J. Raisanen, *AIP Conf. Proc.* 125 (1985) 851
- 1985KO04 D. Konnerth, W. Trombik, K.G. Bernhardt, K.A. Eberhard, R. Singh, A. Strzalkowski and W. Trautmann, *Nucl. Phys.* A436 (1985) 538
- 1985KO1J Koonin, *Lecture Notes in Phys.* 219 (1985) 129
- 1985KO47 P.J.J. Kok, K. Abrahams, H. Postma and W.J. Huiskamp, *Nucl. Instrum. Meth. Phys. Res.* B12 (1985) 325

- 1985KW02 E. Kwasniewicz and L. Jarczyk, Nucl. Phys. A441 (1985) 77
- 1985LI1B Lindstrom et al., Bull. Amer. Phys. Soc. 30 (1985) 747
- 1985LI1E Y.-G. Li and W.-X. Ma, Phys. Energ. Fortis Phys. Nucl. 9 (1985) 291
- 1985MA10 J.F. Mateja, A.D. Frawley, D.G. Kovar, D. Henderson, H. Ikezoe, R.V.F. Janssens, G. Rosner, G.S.F. Stephans, B. Wilkins, K.T. Lesko et al., Phys. Rev. C31 (1985) 867
- 1985MA13 M.T. Magda, A. Pop and A. Sandulescu, J. Phys. (London) G11 (1985) L75
- 1985MAZG B.S. Mazitov and E.N. Rasulov, in Leningrad (1985) 298
- 1985MI1D J. Missimer and L.M. Simons, Phys. Rept. 118 (1985) 179
- 1985MO08 M. Morjean, J.L. Charvet, J.L. Uzureau, Y. Patin, A. Peghaire, Y. Pranal, L. Sinopoli, A. Billerey, A. Chevarier, N. Chevarier et al., Nucl. Phys. A438 (1985) 547
- 1985MU03 S.F. Mughabghab, Phys. Rev. Lett. 54 (1985) 986
- 1985NE05 J.E. Nelson, J. Napolitano and S.J. Freedman, Phys. Rev. C31 (1985) 2295
- 1985NE1C Nemachkalo et al., in Leningrad (1985) 370
- 1985PE06 S.T. Perkins, E.F. Plechaty and R.J. Howerton, Nucl. Sci. Eng. 90 (1985) 83
- 1985PO02 L. Potvin and B. Cujec, Nucl. Phys. A433 (1985) 550
- 1985PO10 N.A.F.M. Poppelier, L.D. Wood and P.W.M. Glaudemans, Phys. Lett. B157 (1985) 120
- 1985PO11 D.N. Poenaru, M. Ivascu, A. Sandulescu and W. Greiner, Phys. Rev. C32 (1985) 572
- 1985RA1A G.M. Raisbeck, F. Yiou, D. Bourles and D.V. Kent, Nature 315 (1985) 315
- 1985RO15 G. Roy, H.S. Sherif, E.D. Cooper, L.G. Greeniaus, G.A. Moss, J. Soukup, G.M. Stinson, R. Abegg, D.P. Gurd, D.A. Hutcheon et al., Nucl. Phys. A442 (1985) 686
- 1985RO17 F. Roig and J. Navarro, Nucl. Phys. A440 (1985) 659
- 1985RO1C Roche et al., Bull. Amer. Phys. Soc. 30 (1985) 1284
- 1985SA1G Y. Sakai, Mem. Fac. Sci. Kyoto Univ. Ser. Phys. Astrophys. Geophys. Chem. 36 (1985) 401
- 1985SA32 H. Sato and Y. Okuhara, Phys. Lett. B162 (1985) 217
- 1985SC08 H.R. Schelin, E. Farrelly Pessoa, W.R. Wylie, J.L. Cardoso, Jr. and R.A. Douglas, Nucl. Sci. Eng. 89 (1985) 87
- 1985SE15 R.E. Segel, S.M. Levenson, P. Zupranski, A.A. Hassan, S. Mukhopadhyay and J.V. Maher, Phys. Rev. C32 (1985) 721
- 1985SH1D Shvedov and Nemets, in Leningrad (1985) 317
- 1985SM08 D.L. Smith, J.W. Meadows and P.T. Guenther, Nucl. Instrum. Meth. Phys. Res. A241 (1985) 507

- 1985TA18 I. Tanihata, H. Hamagaki, O. Hashimoto, Y. Shida, N. Yoshikawa, K. Sugimoto, O. Yamakawa, T. Kobayashi and N. Takahashi, *Phys. Rev. Lett.* 55 (1985) 2676
- 1985TE01 J.A. Templon, J.H. Dave, C.R. Gould and S. Singkarat, *Nucl. Sci. Eng.* 91 (1985) 451
- 1985TE1C Ter-Akopian et al., in *Dubna P15-85-775* (1985)
- 1985TR1A Trentalange et al., *Bull. Amer. Phys. Soc.* 30 (1985) 727
- 1985TR1B Trockel et al., in *Visby* (1985) 148
- 1985TU1B W. Turchinets, *Nucl. Phys.* A446 (1985) 23
- 1985WA02 A.H. Wapstra and G. Audi, *Nucl. Phys.* A432 (1985) 1
- 1985WA13 C.W. Wang, P.G. Roos, N.S. Chant, G. Ciangaru, F. Khazaie, D.J. Mack, A. Nadasen, S.J. Mills, R.E. Warner, E. Norbeck et al., *Phys. Rev.* C31 (1985) 1662
- 1985WA1K T.P. Walker, G.J. Mathews and V.E. Viola, *Astrophys. J.* 299 (1985) 745
- 1985WE1A Wefel, Guzik, Garcia-Munoz and Simpson, *Bull. Amer. Phys. Soc.* 30 (1985) 764
- 1985WI18 J.S. Winfield, N.A. Jelley, W.D.M. Rae and C.L. Woods, *Nucl. Phys.* A437 (1985) 65
- 1985WI1B D. Wilkinson, *Nucl. Phys.* A434 (1985) 573
- 1985YI1A Yiou et al., *Nature* 316 (1985) 616
- 1985ZI04 W. Ziegler, E.G. Auld, W.R. Falk, G.L. Giles, G. Jones, G.J. Lolos, B.J. McParland, P.L. Walden and D.F. Ottewell, *Phys. Rev.* C32 (1985) 301
- 1985ZI05 W. Zickendraht, *Ann. Phys.* 42 (1985) 113
- 1986AB10 S.N. Abramovich, B.Ya. Guzhovsky, A.V. Ershov and L.M. Lazarev, *Izv. Akad. Nauk SSSR Ser. Fiz.* 50 (1986) 2021; *Bull. Acad. Sci. USSR Phys. Ser.* 50 (1986) 148
- 1986AJ01 F. Ajzenberg-Selove, *Nucl. Phys.* A449 (1986) 1
- 1986AL1J Allab, in *Santa Fe* (1985) 825
- 1986AN1F B. Andersson, S. Garpman, G. Gustafson, H.-A. Gustafsson, B. Nilsson-Almqvist, I. Otterlund and E. Stenlund, *Phys. Scripta* 34 (1986) 451
- 1986AN1R H.H. Ansari, M. Shoeb and M.Z.R. Rahman Khan, *J. Phys. (London)* G12 (1986) 1369
- 1986AR04 K.P. Artemov, M.S. Golovkov, V.Z. Goldberg, I.P. Petrov, V.P. Rudakov, I.N. Serikov and V.A. Timofeev, *Yad. Fiz.* 43 (1986) 529; *Sov. J. Nucl. Phys.* 43 (1986) 335
- 1986AV01 G.V. Avakov, L.D. Blokhintsev, A.M. Mukhamedzhanov and R. Yarmukhamedov, *Yad. Fiz.* 43 (1986) 824; *Sov. J. Nucl. Phys.* 43 (1986) 524
- 1986AV1A V.V. Avdeichikov, A.I. Bogdanov, V.A. Budilov, N.K. Zhidkov, N.L. Gorshkova, A. Kotus, Yu.A. Murin, V.A. Nikitin, P.V. Nomokonov and M.D. Traikova, *Yad. Fiz.* 44 (1986) 440; *Sov. J. Nucl. Phys.* 44 (1986) 282
- 1986AV1B Avdeichikov, in *Dubna* (1986) 122

- 1986BA1W H. Bando, Nucl. Phys. A450 (1986) 217c
- 1986BA1X Barker, 11th Ains Nucl. Phys. Conf., Melbourne, Australia (1986) 89
- 1986BA40 F.M. Baumann, G. Domogala, H. Freiesleben, H.J. Paul, S. Puhlvers and H. Sohlbach, Nucl. Instrum. Meth. Phys. Res. A247 (1986) 359
- 1986BA69 D. Baye, Nucl. Phys. A460 (1986) 581
- 1986BA88 W. Bauhoff, At. Data Nucl. Data Tables 35 (1986) 429
- 1986BE1P Bernstein, Private Communication (1986)
- 1986BO1E A.R. Bodmer and Q.N. Usmani, Nucl. Phys. A450 (1986) 257c
- 1986CA1L Carnoy, Deutsch, Girard and Prieels, Proc. Int. Symp., Heidelberg, Germany (1986) 534
- 1986CA30 L. Carlen, H.-A. Gustafsson, B. Jakobsson, A. Kristiansson, A. Oskarsson, H. Ryde, M. Westenius, J.P. Bondorf, O.-B. Nielsen, G. Lovhoiden et al., Phys. Scr. 34 (1986) 475
- 1986CAZT D.D.P. Casavant and L.D. Knutson, Bull. Amer. Phys. Soc. 31 (1986) 1224, DB2
- 1986CH1P R.E. Chrien, Czech. J. Phys. B36 (1986) 410
- 1986CO14 C.M. Conneely, W.V. Prestwich and T.J. Kennett, Nucl. Instrum. Meth. Phys. Res. A248 (1986) 416
- 1986CR1A Crawford et al., Bull. Amer. Phys. Soc. 31 (1986) 888
- 1986CS1A L.P. Csernai and J.I. Kapusta, Phys. Rept. 131 (1986) 223
- 1986CU02 B. Cujec, B. Dasmahapatra, Q. Haider, F. Lahlou and R.A. Dayras, Nucl. Phys. A453 (1986) 505
- 1986DA1B D.H. Davis and J. Pniewski, Contemp. Phys. 27 (1986) 91
- 1986DE25 F.W.N. De Boer, K. Abrahams, A. Balanda, H. Bokemeyer, R. van Dantzig, J.F.W. Jansen, B. Kotlinski, M.J.A. De Voigt and J. van Klinken, Phys. Lett. B180 (1986) 4
- 1986DO12 P. Doll, G. Fink, F.P. Brady, R. Garrett, H.O. Klages and H. Krupp, Nucl. Instrum. Meth. Phys. Res. A250 (1986) 526
- 1986DO1E Dolbilskaa et al., in Kharkov (1986) 352
- 1986DU1G Du and Zhang, Proc. 4th Int. Symp., Smolenice, Czechoslovakia, 1985 (1986) 108
- 1986EN1A Engelmann and Bardy, Rept. CEA-R-5340 (1986)
- 1986ER1B Ergakov et al., Czech. J. Phys. 36 (1986) 985
- 1986FRZZ M.B. Frodyma, B. Debebe, J. Dubach, R.S. Hicks, R.L. Huffman, G.A. Peterson, R.P. Singhal and A. Hotta, Bull. Amer. Phys. Soc. 31 (1986) 877, JJ13
- 1986GA1F M. Gazdzicki, K. Iovchev, E. Kladnitskaya, E. Okonov and E.Z. Skrzypczak, Z. Phys. C31 (1986) 549

- 1986GA1H A. Gal, AIP Conf. Proc. 150 (1986) 127
- 1986GI10 A. Gillibert, L. Bianchi, A. Cunsolo, B. Fernandez, A. Foti, J. Gastebois, Ch. Gregoire, W. Mittig, A. Peghaire, Y. Schutz et al., Phys. Lett. B176 (1986) 317
- 1986GL1A Glaudemans, AIP Conf. Proc. 142 (1986) 316
- 1986GLZV Yu.A. Glukhov, E.I. Koshchy, Yu.G. Mashkarov, E.Yu. Nikolsky, A.T. Rudchik, S.B. Sakuta and K.F. Ustimenkov, in Kharkov (1986) 370
- 1986GO1L Gould et al., in Santa Fe 85 (1986) 139
- 1986GO28 N.F. Golovanova and V.V. Kurovsky, Izv. Akad. Nauk SSSR Ser. Fiz. 50 (1986) 963; Bull. Acad. Sci. USSR Phys. Ser. 50 (1986) 131
- 1986GU1G Gurev and Zolewnko, in Harrogate (1986) C260
- 1986HA1B B.G. Harvey, J. Phys. Colloq. (Paris) 47 (1986) C4-29
- 1986HA1K Y. Haneishi and T. Fujita, Phys. Rev. C33 (1986) 260
- 1986HA1M Han, Jeong, Park and Cheon, New Phys. 26 (1986) 16
- 1986HO23 B. Hoistad, M. Barlett, G.S. Adams, M. Gazzaly, B. Aas, G. Pauletta, F. Irom, K. Jones and J.A. McGill, Phys. Lett. B177 (1986) 299
- 1986IS04 Y. Iseri and M. Kawai, Phys. Rev. C34 (1986) 38
- 1986KO1R Korteling et al., Int. Conf. on Nucl. Radiochem., 1-5 Sept. 1986, Beijing, China (1986) 37
- 1986MA19 J.F. Mateja, A.D. Frawley, L.C. Dennis and K. Sartor, Phys. Rev. C33 (1986) 1649
- 1986MA1C L. Majling, J. Zofka, V.N. Fetisov and R.A. Eramzhyan, Nucl. Phys. A450 (1986) 189c
- 1986MA1W M. May, Nucl. Phys. A450 (1986) 179c
- 1986ME06 M.C. Mermaz, T. Suomijarvi, R. Lucas, B. Berthier, J. Matuszek, J.P. Coffin, G. Guillaume, B. Heusch, F. Jundt and F. Rami, Nucl. Phys. A456 (1986) 186
- 1986MEZZ M. Meier, D. Holtkamp, G. Morgan, H. Robinson, G. Russell, R. Whitaker, W. Amian and N. Paul, Bull. Amer. Phys. Soc. 31 (1986) 1111
- 1986MO13 D.J. Morrissey, C. Bloch, W. Benenson, E. Kashy, R.A. Blue, R.M. Ronningen and R. Aryaeinejad, Phys. Rev. C34 (1986) 761
- 1986MOZV D.J. Morrissey, C. Bloch, W. Benenson and E. Kashy, Bull. Amer. Phys. Soc. 31 (1986) 840
- 1986MU07 K. Murphy, R.C. Byrd, C.E. Floyd, P.P. Guss and R.L. Walter, Nucl. Phys. A455 (1986) 525
- 1986MU08 K. Murphy, R.C. Byrd, C.R. Howell and R.L. Walter, Radiat. Eff. 92 (1986) 219
- 1986MU1B Mughabghab, Phys. Rev. Lett. 56 (1986) 399
- 1986NA15 K. Nakayama and G. Bertsch, Phys. Rev. C34 (1986) 2190

- 1986NI1A Nishizumi et al., Nature 319 (1986) 134
- 1986OV1A Overley, Bull. Amer. Phys. Soc. 31 (1986) 1309
- 1986PE05 J.P. Perroud, A. Perrenoud, J.C. Alder, B. Gabioud, C. Joseph, J.F. Loude, N. Morel, M.T. Tran, E. Winkelmann, H. Von Fellenberg et al., Nucl. Phys. A453 (1986) 542
- 1986PO06 D.N. Poenaru, W. Greiner, K. Depta, M. Ivascu, D. Mazilu and A. Sandulescu, At. Data Nucl. Data Tables 34 (1986) 423
- 1986PO1H B. Povh, Nucl. Phys. A450 (1986) 573c
- 1986RA16 G. Ramachandran and V. Ravishankar, J. Phys. G12 (1986) 1221
- 1986RA1B Raman and Lynn, Phys. Rev. Lett. 56 (1986) 398
- 1986RO03 R. Rockmore and B. Saghai, Phys. Rev. C33 (1986) 576
- 1986RO12 G. Royer, J. Phys. (London) G12 (1986) 623
- 1986SA30 H. Sato and Y. Okuhara, Phys. Rev. C34 (1986) 2171
- 1986SAZR E.T. Sadowski, H.D. Knox, D.A. Resler and R.O. Lane, Bull. Amer. Phys. Soc. 31 (1986) 1209
- 1986SH1F W.Q. Shen, S.Z. Yin, Z.Y. Guo, W.L. Zhan, Y.T. Zhu, G.M. Jin, W.M. Qiao, E.C. Wu and C.L. Jiang, Chin. Phys. 6 (1986) 80
- 1986SH1M Shardanov and Yurev, Vestn. Mosk. Univ. Ser. 3 (1986) 66
- 1986SIZS P.J. Simmonds, N.M. Clarke, K.I. Pearce, R.J. Griffiths, C.A. Ogilvie and M. Mannion, in Harrogate (1986) 315
- 1986SO10 L.G. Sobotka, D.G. Sarantites, H. Puchta, F.A. Dilmanian, M. Jaaskelainen, M.L. Halbert, J.H. Barker, J.R. Beene, R.L. Ferguson, D.C. Hensley et al., Phys. Rev. C34 (1986) 917
- 1986ST1E E. Steffens, J. Phys. Soc. Jpn. Suppl. 55 (1986) 459
- 1986SU1H Suter, Bull. Amer. Phys. Soc. 31 (1986) 1267
- 1986TE1A G.M. Ter-Akopian, Pham Ngoc Chuong, N.V. Yerebin, V.F. Strizhov, A.P. Kabachenko and L.P. Chelnokov, Nucl. Instrum. Meth. Phys. Res. B17 (1986) 393, and Private Communication (1986)
- 1986UT01 H. Utsunomiya, E.C. Deci, R.A. Blue, L.H. Harwood, R.M. Ronningen, K. Siwek-Wilczynska, J. Wilczynski and D.J. Morrissey, Phys. Rev. C33 (1986) 185
- 1986VDZY A.I. Vdovin, I.G. Golikov, A.V. Golovin, M.H. Zhukov, I.I. Loshchakov and V.I. Ostroumov, in Kharkov (1986) 290
- 1986WA1J X.-C. Wang, H. Takaki and H. Bando, Prog. Theor. Phys. 76 (1986) 865
- 1986WE1E Wei et al., Bull. Amer. Phys. Soc. 31 (1986) 1294
- 1986WI04 D.H. Wilkinson, Nucl. Phys. A452 (1986) 296

- 1986XU02 H.M. Xu, D.J. Fields, W.G. Lynch, M.B. Tsang, C.K. Gelbke, M.R. Maier, D.J. Morrissey, J. Pochodzalla, D.G. Sarantites, L.G. Sobotka et al., Phys. Lett. B182 (1986) 155
- 1986XU1B H.M. Xu and W.G. Lynch, Int. Conf. on Nucl. Radiochem., 1-5 Sept. 1986, Beijing, China (1986) 54
- 1986YA07 M. Yamazaki, K. Shoda, M. Torikoshi, O. Sasaki and H. Tsubota, Phys. Rev. C34 (1986) 1123
- 1986YA15 K. Yabana and H. Horiuchi, Prog. Theor. Phys. 76 (1986) 1071
- 1986YA1F Y. Yamamoto, Prog. Theor. Phys. 75 (1986) 639
- 1986ZH03 M.A. Zhusupov, O. Imambekov and Yu.N. Uzikov, Izv. Akad. Nauk SSSR Ser. Fiz. 50 (1986) 178; Bull. Acad. Sci. USSR Phys. Ser. 50 (1986) 172
- 1986ZH1B F. Zhuang and H.Z. Chen, Chin. J. Nucl. Phys. 8 (1986) 325
- 1987AB09 S.N. Abramovich, L.A. Morkin, V.I. Serov and Yu.V. Strelnikov, Izv. Akad. Nauk SSSR Ser. Fiz. 51 (1987) 930; Bull. Acad. Sci. USSR Phys. Ser. 51 (1987) 92
- 1987AB15 S.N. Abramovich, B.Ya. Guzhovsky, A.V. Ershov and L.M. Lazarev, Yad. Fiz. 46 (1987) 499; Sov. J. Nucl. Phys. 46 (1987) 269
- 1987AB1H Abramovich et al., in Yurmala (1987) 521
- 1987AH02 M.H. Ahsan, S.A. Siddiqui and H.H. Thies, Nucl. Phys. A469 (1987) 381
- 1987AK1A Akhverdyan et al., in Panic (1987) 708
- 1987ALZG D.V. Aleksandrov, Yu.A. Glukhov, E. Yu. Nikolsky, B.G. Novatsky, A.A. Ogloblin and D.N. Stepanov, in Yurmala (1987) 393
- 1987AR19 S.E. Arnell, S. Mattsson, H.A. Roth, M. Rydehell, O. Skeppstedt, A. Johnson, J. Nyberg, A. Kerek and A. Nilsson, Phys. Scr. 36 (1987) 214
- 1987AR1C Arnould, Phil. Trans. Roy. Soc. (London) 323 (1987) 251
- 1987AU1A J. Audouze, J. Astrophys. Astron. 8 (1987) 147
- 1987BA2J W.A. Bardeen, R.D. Peccei and T. Yanagida, Nucl. Phys. B279 (1987) 401
- 1987BA34 S. Barhoumi, M. Allab, H. Beaumevieille, A.C. Chami and Z. Meliani, Nucl. Instrum. Meth. Phys. Res. B24-25 (1987) 477
- 1987BA38 G.J. Balster, P.C.N. Crouzen, P.B. Goldhoorn, R.H. Siemssen and H.W. Wilschut, Nucl. Phys. A468 (1987) 93
- 1987BA39 G.J. Balster, H.W. Wilschut, R.H. Siemssen, P.C.N. Crouzen, P.B. Goldhoorn and Z. Sujkowski, Nucl. Phys. A468 (1987) 131
- 1987BE1X Beer et al., Nucl. Instrum. Meth. Phys. Res. B29 (1987) 203
- 1987BEYI A.V. Belozyorov, C. Borcea, Z. Dlouhy, A.M. Kalinin, N.H. Chau and Yu.E. Penionzhkevich, JINR-E15-87-733 (1987)

- 1987BI1C Bimbot et al., in Panic (1987) 370
- 1987BL18 R. Blumel and K. Dietrich, Nucl. Phys. A471 (1987) 453
- 1987BO1L A.R. Bodmer and Q.N. Usmani, Nucl. Phys. A463 (1987) 221c
- 1987BO1O A.R. Bodmer and Q.N. Usmani, Nucl. Phys. A468 (1987) 653
- 1987BR1Q Brown, Phil. Trans. Roy. Soc. (Lodon) A323 (1987) 75
- 1987BR1U Brown et al., Nucl. Instrum. Meth. Phys. Res. B29 (1987) 232
- 1987BU07 M. Burgel, H. Fuchs, H. Homeyer, G. Ingold, U. Jahnke and G. Thoma, Phys. Rev. C36 (1987) 90
- 1987BU27 N.T. Burtebaev, A.D. Duisebaev, V.S. Sadkovskii and G.A. Feofilov, Izv. Akad. Nauk SSSR Ser. Fiz. 51 (1987) 615; Bull. Acad. Sci. USSR Phys. Ser. 51 (1987) 191
- 1987CH26 Z. Chen, C.K. Gelbke, J. Pochodzalla, C.B. Chitwood, D.J. Fields, W.G. Gong, W.G. Lynch and M.B. Tsang, Nucl. Phys. A473 (1987) 564
- 1987CO16 J. Cook, M.N. Stephens and K.W. Kemper, Nucl. Phys. A466 (1987) 168
- 1987DE1P de Boer et al., Nucl. Instrum. Meth. Phys. Res. B29 (1987) 322
- 1987DE37 F. Deak, A. Kiss, Z. Seres, G. Caskey, A. Galonsky and B. Remington, Nucl. Instrum. Meth. Phys. Res. A258 (1987) 67
- 1987DE43 H. De Vries, C.W. De Jager and C. De Vries, At. Data Nucl. Data Tables 36 (1987) 495
- 1987EI1A Eisenhauer et al., Nucl. Instrum. Meth, Phys. Res. B29 (1987) 326
- 1987EL1E Elmore et al., Nucl. Instrum. Meth. Phys. Res. B29 (1987) 207
- 1987FE1A E.-P. Feng, Q. Wang, Y.-T. Zhu, X. Yin, H.-B. Miao, S.-M. Sun, S.-L. Li, Z.-L. Wu, G.-Y. Fan, Y.-X. Xie et al., Chin. Phys. 7 (1987) 121
- 1987FL1A Flerov, in Dubna (1987) 9
- 1987FR16 J. Franz, E. Rossle, C. Sauerwein, H. Schmitt, H.L. Woolverton, J. Ero, Z. Fodor, J. Kecskemeti, P. Koncz, Zs. Kovacs et al., Nucl. Phys. A472 (1987) 733
- 1987GA08 E. Gadioli and E. Gadioli Erba, Z. Phys. A327 (1987) 81
- 1987GA20 A.K. Ganguly, B. Chaudhuri and B.B. Baliga, Nuovo Cim. A97 (1987) 639
- 1987GE1B C.-K. Gelbke and D.H. Boal, Prog. Part. Nucl. Phys. 19 (1987) 33
- 1987GIZZ R.A. Giannelli, J.R. Comfort, J.A. McGill, C. Glashausser, C.L. Morris, L.C. Bland, P.A. Seidl, A. Boudard, B. Bonin, B. Silverman et al., Bull. Amer. Phys. Soc. 32 (1987) 1120, KF3
- 1987GL06 H. Glattli, J. Coustham, A. Malinovski and M. Pinot, Z. Phys. A327 (1987) 149
- 1987GO1W Gove, Litherland and Purser, Nucl. Instrum. Meth. Phys. Res. B29 (1987) 437

- 1987GR11 R.E.L. Green, R.G. Korteling, J.M. D'Auria, K.P. Jackson and R.L. Helmer, Phys. Rev. C35 (1987) 1341
- 1987GR1Q Graf et al., Nucl. Instrum. Meth. Phys. Res. B29 (1987) 262
- 1987GU04 R.K. Gupta, S. Gulati, S.S. Malik and R. Sultana, J. Phys. G13 (1987) L27
- 1987GUZZ I.R. Gulamov, T. Iskhakov, A.M. Mukhamedzhanov, Sh. Kayumov, A.A. Karakhodzhaev, G.K. Ni, E.A. Romanovsky and G.S. Valiev, in Yurmala (1987) 344
- 1987HA1O Hallin et al., Nucl. Instrum. Meth. Phys. Res. B24-25 (1987) 276
- 1987HA1R Hansen, Nature 328 (1987) 476
- 1987HA30 P.G. Hansen and B. Jonson, Europhys. Lett. 4 (1987) 409
- 1987HAZS L.F. Hansen, F.S. Dietrich and R.L. Walter, Bull. Amer. Phys. Soc. 32 (1987) 1567, DB8
- 1987HE1H T.K. Hemmick, D. Elmore, P.W. Kubik, S.L. Olsen, T. Gentile, D. Nitz, D. Ciampa, H. Kagan, P. Haas, P.F. Smith et al., Nucl. Instrum. Meth. Phys. Res. B29 (1987) 389
- 1987HI05 D. Hilscher, H. Rossner, A. Gamp, U. Jahnke, B. Cheynis, B. Chambon, D. Drain, C. Pastor, A. Giorni, C. Morand et al., Phys. Rev. C36 (1987) 208
- 1987HI1F Hicks et al., in Panic (1987) 632
- 1987HO1P Hofmann et al., Nucl. Instrum. Meth. Phys. Res. B29 (1987) 32
- 1987HU13 J.R. Hurd, J.S. Boswell, R.C. Minehart, Y. Tzeng, H.J. Ziock, K.O.H. Ziock, L.C. Liu and E.R. Siciliano, Nucl. Phys. A475 (1987) 743
- 1987IN1A K.G.W. Inn, S. Raman, B.M. Coursey, J.D. Fassett and R.L. Walker, Nucl. Instrum. Meth. Phys. Res. B29 (1987) 27
- 1987JA06 B.V. Jacak, G.D. Westfall, G.M. Crawley, D. Fox, C.K. Gelbke, L.H. Harwood, B.E. Hasselquist, W.G. Lynch, D.K. Scott, H. Stocker et al., Phys. Rev. C35 (1987) 1751
- 1987JA1G Jansen et al., Nucl. Instrum. Meth. Phys. Res. B29 (1987) 311
- 1987KA25 K. Kadija, G. Paic, D. Vranic, A. Berdoz, F. Foroughi, Ch. Nussbaum, H.H. Muller, P. Schober and St. Steiner, Nucl. Phys. A469 (1987) 183
- 1987KAZL F. Kadirov, M.A. Kayumov, Sh. Kayumov, A.M. Mukhamedzhanov, U.I. Faizullaev, K. Khamidova and R. Yarmukhamedov, in Yurmala (1987) 343
- 1987KI05 A. Kiss, F. Deak, Z. Seres, G. Caskey, A. Galonsky, L. Heilbronn, B.A. Remington and J. Kasagi, Phys. Lett. B184 (1987) 149
- 1987KI1C H.R. Kissener, I. Rotter and N.G. Goncharova, Fortschr. Phys. 35 (1987) 277
- 1987KO15 T. Kozik, J. Buschmann, K. Grotowski, H.J. Gils, N. Heide, J. Kiener, H. Klewe-Nebenius, H. Rebel, S. Zagromski, A.J. Cole et al., Z. Phys. A326 (1987) 421
- 1987KO1Y Kobayashi et al., in Panic (1987) 476

- 1987KU1L M. Kusakabe, T.L. Ku, J.R. Southon, J.S. Vogel, D.E. Nelson, C.I. Measures and Y. Nozaki, Nucl. Instrum. Meth. Phys. Res. B29 (1987) 306
- 1987KU23 Y. Kuno, K. Nagamine and T. Yamazaki, Nucl. Phys. A475 (1987) 615
- 1987KW01 E. Kwasniewicz and J. Kisiel, J. Phys. (London) G13 (1987) 121
- 1987LA16 D. Lal, K. Nishiizumi, R.C. Reedy, M. Suter and W. Wolfli, Nucl. Phys. A468 (1987) 189; Erratum Nucl. Phys. A481 (1988) 834
- 1987LA1G Lal et al., Nature 328 (1987) 139
- 1987LA1I Lal, Nucl. Instrum. Meth. Phys. Res. B29 (1987) 238
- 1987LE1E Leisi et al., Helv. Phys. Acta. 60 (1987) 316
- 1987LE33 F.S. Levin, Nucl. Phys. A463 (1987) 487c
- 1987LY01 J.E. Lynn, S. Kahane and S. Raman, Phys. Rev. C35 (1987) 26
- 1987LY04 W.G. Lynch, Nucl. Phys. A471 (1987) 309c
- 1987MI38 M. Mian, Phys. Rev. C35 (1987) 1463
- 1987MO04 A. Moalem, D. Frekers, S.A. Gurvitz, R. Abegg, C. Davis, K.P. Jackson, C.A. Miller, R.S. Henderson, S. Yen, R.L. Helmer et al., Phys. Lett. B183 (1987) 269
- 1987MO1F Morinaga, Proc. Beijing Int. Symp. on Phys. at Tandem, 1986 (1987) 583
- 1987MU03 J.A. Muzycka and B.I. Pustylnik, Yad. Fiz. 45 (1987) 90; Sov. J. Nucl. Phys. 45 (1987) 57
- 1987MU13 D.E. Murnick, E.G. Myers, M.M. Lowry and F.P. Calaprice, Phys. Rev. Lett. 59 (1987) 1088
- 1987NA01 M.N. Namboodiri, R.K. Choudhury, L. Adler, J.D. Bronson, D. Fabris, U. Garg, P.L. Gonthier, K. Hagel, D.R. Haenni, Y.W. Lui et al., Phys. Rev. C35 (1987) 149
- 1987NA04 J. Navarro and F. Roig, Nucl. Phys. A465 (1987) 628
- 1987NA1M Nagai et al., Nucl. Instrum. Meth. Phys. Res. B29 (1987) 266
- 1987OE1A Oeschger, Beer and Andree, Phil. Trans. Roy. Soc. (London) A323 (1987) 45
- 1987PE1C Penionshkevich, in Dubna (1987) 364
- 1987PO1H B. Povh, Prog. Part. Nucl. Phys. 18 (1987) 183
- 1987PO23 J. Pochodzalla, Nucl. Phys. A471 (1987) 289c
- 1987RA01 S. Raman, C.H. Malarkey, W.T. Milner, C.W. Nestor, Jr. and P.H. Stelson, At. Data Nucl. Data Tables 36 (1987) 1
- 1987RA1D R. Ramaty and R.J. Murphy, Space Sci. Rev. 45 (1987) 213
- 1987RA1N Raisbeck et al., Nucl. Instrum. Meth. Phys. Res. B29 (1987) 22
- 1987RA36 M. Rahman, H.M. Sen Gupta, Md.A. Rahman and A.B. Siddique, Nuovo Cim. A98 (1987) 513

- 1987RE1H Reedy, Nucl. Instrum. Meth. Phys. Res. B29 (1987) 251
- 1987RI03 J. Richert and P. Wagner, Nucl. Phys. A466 (1987) 132
- 1987RO10 G. Royer, Y. Raffray, A. Oubahadou and B. Remaud, Nucl. Phys. A466 (1987) 139
- 1987RO25 C. Rolfs, H.P. Trautvetter and W.S. Rodney, Rept. Prog. Phys. 50 (1987) 233
- 1987SA15 H. Sagawa and H. Toki, J. Phys. (London) G13 (1987) 453
- 1987SAZW K. Sartor, L.C. Dennis and X. Aslanoglou, Bull. Amer. Phys. Soc. 32 (1987) 1061
- 1987SAZX E.T. Sadowski, H.D. Knox, D.A. Resler and R.O. Lane, Bull. Amer. Phys. Soc. 32 (1987) 1061
- 1987SE05 K.K. Seth, M. Artuso, D. Barlow, S. Iversen, M. Kaletka, H. Nann, B. Parker and R. Soundranayagam, Phys. Rev. Lett. 58 (1987) 1930
- 1987SE1D J.P.F. Sellschop, Nucl. Instrum. Meth. Phys. Res. B29 (1987) 439
- 1987SE1E Segl et al., Nucl. Instrum. Meth. Phys. Res. B29 (1987) 332
- 1987SH1N Sharma et al., Nucl. Instrum. Meth. Phys. Res. B29 (1987) 335
- 1987SI18 P.B. Siegel and W.R. Gibbs, Phys. Rev. C36 (1987) 2473
- 1987SN01 K. Sneppen, Nucl. Phys. A470 (1987) 213
- 1987SO1E C.P. Sonett, G.E. Morfill and J.R. Jokipii, Nature 330 (1987) 458
- 1987ST01 G.S.F. Stephans, R.V.F. Janssens, D.G. Kovar and B.D. Wilkins, Phys. Rev. C35 (1987) 614
- 1987SU06 T. Suzuki, D.F. Measday and J.P. Roalsvig, Phys. Rev. C35 (1987) 2212
- 1987TAZU I. Tanihata, H. Hamagaki, O. Hashimoto, Y. Shida, O. Yamakawa, T. Kobayashi, K. Sugimoto and N. Takahashi, in Panic (1987) 474; LBL-22820 (1987) 82
- 1987TR05 W. Trautmann, K.D. Hildenbrand, U. Lynen, W.F.J. Muller, H.J. Rabe, H. Sann, H. Stelzer, R. Trockel, R. Wada, N. Brummund et al., Nucl. Phys. A471 (1987) 191c
- 1987VA13 O.I. Vasileva, G.S. Gurevich, A.V. Ignatenko, V.M. Lebedev, N.V. Orlova, A.V. Spassky, I.B. Teplov, L.N. Fateeva, G.V. Shakhvorostova and A.Kh. El-Kamkhavi, Yad. Fiz. 45 (1987) 312; Sov. J. Nucl. Phys. 45 (1987) 195
- 1987VA1I Valiev et al., in Yurmala (1987) 346
- 1987VA1S van der Borg et al., Nucl. Instrum. Meth. Phys. Res. B29 (1987) 143
- 1987VI02 F. Videbaek, S.G. Steadman, G.G. Batrouni and J. Karp, Phys. Rev. C35 (1987) 2333
- 1987VI14 V.E. Viola, Nucl. Phys. A471 (1987) 53c
- 1987WA09 R. Wada, K.D. Hildenbrand, U. Lynen, W.F.J. Muller, H.J. Rabe, H. Sann, H. Stelzer, W. Trautmann, R. Trockel, N. Brummund et al., Phys. Rev. Lett. 58 (1987) 1829
- 1987WU05 R. Wunsch and J. Zofka, Phys. Lett. B193 (1987) 7
- 1987YA16 Yu.P. Yakovlev, Yad. Fiz. 46 (1987) 459; Sov. J. Nucl. Phys. 46 (1987) 244

- 1987ZA01 M. Zadro, S. Blagus, D. Miljanic and D. Rendic, Nucl. Sci. Eng. 95 (1987) 79
- 1988AB05 V.V. Abaev, E.P. Fedorova-Koval, A.B. Gridnev, V.P. Koptev, S.P. Kruglov, Yu.A. Malov, G.V. Scherbakov, I.I. Strakovsky and N.A. Tarasov, J. Phys. G14 (1988) 903
- 1988ABZW S.N. Abramovich, B.Ya. Guzhovsky and V.N. Protopopov, in Baku (1988) 299
- 1988AJ1B F. Ajzenberg-Selove, Interact. and Struct. in Nucl., Proc. in Honor of D.H. Wilkinson, Sussex, 7-9 Sept. 1987 (1988) 181
- 1988AL1G Aleksandrov et al., in Baku (1988) 377
- 1988BE1B J. Beer, U. Siegenthaler, G. Bonani, R.C. Finkel, H. Oeschger, M. Suter and W. Wolfli, Nature 331 (1988) 675
- 1988BE1I Bekbaev et al., in Baku (1988) 442
- 1988BEYJ A.V. Belozherov, K. Borcha, I. Vintsour, Z. Dlougy, N.K. Tyau and Yu.Eh. Penionzhkevich, in Baku (1988) 380.
- 1988BL09 C. Bloch, W. Benenson, A.I. Galonsky, E. Kashy, J. Heltsley, L. Heilbronn, M. Lowe, R.J. Radtke, B. Remington, J. Kassagi et al., Phys. Rev. C37 (1988) 2469
- 1988BO47 K. Bodek, B. Bruggemann, J. Krug, P. Lekkas, W. Lubcke, H. Ruhl, M. Steinke, M. Stephan, A. Szczurek and D. Kamke, Few-Body Syst. 3 (1988) 135
- 1988BRZZ B.A. Brown, R.E. Julies and W.A. Richter, Bull. Amer. Phys. Soc. 33 (1988) 931
- 1988CA06 G. Caskey, L. Heilbronn, B. Remington, A. Galonsky, F. Deak, A. Kiss and Z. Seres, Phys. Rev. C37 (1988) 696
- 1988DI02 S.S. Dietrich and B.L. Berman, At. Data Nucl. Data Tables 38 (1988) 199
- 1988FE1A Ferrando et al., Phys. Rev. C37 (1988) 1490
- 1988GI02 T.A. Girard, A.S. Carnoy, J. Deutsch, R. Prieels and M.L. Schmit, Z. Phys. A330 (1988) 51
- 1988GI1B B.F. Gibson, Nucl. Phys. A479 (1988) 115c
- 1988GIZT Yu.R. Gismatullin, A.A. Melentev, V.I. Ostroumov, A.M. Petukhov and M.A. Stalevich, in Baku (1988) 294
- 1988GIZU Yu.R. Gismatullin, A.A. Melentev, V.I. Ostroumov, A.M. Petukhov and M.A. Stalevich, in Baku (1988) 293
- 1988GOZB S.A. Goncharov, E.A. Romanovsky and N.K. Timofeyuk, in Baku (1988) 349
- 1988GUZW I.R. Gulamov, A.M. Mukhamedzhanov and G.K. Ni, in Baku (1988) 300
- 1988HA1M W.C. Haxton and C.W. Johnson, Nature 333 (1988) 325
- 1988HE08 R. Henneck, C. Gysin, P. Haffter, M. Hammans, W. Lorenzon, M.A. Pickar, I. Sick and S. Burzynski, Phys. Rev. C37 (1988) 2224
- 1988JO1C B. Jonson, S. Mattsson, G. Nyman, O. Tengblad, M.J.G. Borge, P.G. Hansen and K. Riisager, AIP Conf. Proc. 164 (1988) 223

- 1988KA2E Kayomov et al., in Baku (1988) 301
- 1988KI05 J.M. Kidd, P.J. Lindstrom, H.J. Crawford and G. Woods, Phys. Rev. C37 (1988) 2613
- 1988KOZL L.P. Korda, B.A. Nemashkalo, G.K. Khomyakov, A.S. Kachan and A.N. Vodin, in Baku (1988) 586
- 1988KR11 L. Kraus, A. Boucenna, I. Linck, B. Lott, R. Rebmeister, N. Schulz, J.C. Sens, M.C. Mermaz, B. Berthier, R. Lucas et al., Phys. Rev. C37 (1988) 2529
- 1988KR1G Krombel and Wiedenbeck, Astrophys. J. 328 (1988) 940
- 1988KRZY M. Kroupa, S.J. Freedman, R. Holzmann, J. Napolitano, J. Nelson, P. Barker and S. Ferguson, Bull. Amer. Phys. Soc. 33 (1988) 902
- 1988KW02 E. Kwasniewicz and J. Kisiel, Acta Phys. Pol. B19 (1988) 141
- 1988LE06 M. LeMere and Y.C. Tang, Phys. Rev. C37 (1988) 1369
- 1988MA07 J.F. Mateja, G.L. Gentry, N.R. Fletcher, L.C. Dennis and A.D. Frawley, Phys. Rev. C37 (1988) 1004
- 1988MU05 S.F. Mughabghab, J. Phys. (London) G14 Suppl. (1988) S231
- 1988OR1C Ormand and Brown, NBI-87-63 (1988)
- 1988POZS N.A.F.M. Poppelier, J.H. de Vries, A.A. Wolters and P.W.M. Glaudemans, AIP Conf. Proc. 164 (1988) 334
- 1988RE1B R. Rebolo, P. Molaro, C. Abia and J.E. Beckman, Astron. Astrophys. 193 (1988) 193
- 1988RIZZ B.G. Ritchie, D. Rothenberger, J.R. Comfort, R.A. Giannelli, J. Tinsley, N.S. Chant, D. Mack, P.G. Roos, J.D. Silk, G.S. Kyle et al., Bull. Amer. Phys. Soc. 33 (1988) 903, AI11
- 1988RU01 V.A. Rubchenya and S.G. Yavshits, Z. Phys. A329 (1988) 217
- 1988SA19 H. Sato, Phys. Rev. C37 (1988) 2902
- 1988SI01 J.D. Silk, H.D. Holmgren, D.L. Hendrie, T.J.M. Symons, G.D. Westfall, P.H. Stelson, S. Raman, R.L. Auble, J.R. Wu and K. Van Bibber, Phys. Rev. C37 (1988) 158
- 1988ST06 J. Stevenson, B.A. Brown, Y. Chen, J. Clayton, E. Kashy, D. Mikolas, J. Nolen, M. Samuel, B. Sherrill, J.S. Winfield et al., Phys. Rev. C37 (1988) 2220
- 1988SU14 T. Suda, O. Konno, I. Nomura, T. Suzuki, T. Terasawa, Y. Torizuka, J. Yokokawa, K. Maeda, J. Eden, G. O'Keefe et al., J. Phys. Soc. Jpn. 57 (1988) 5
- 1988TS03 M.B. Tsang, W.G. Lynch, R.M. Ronningen, Z. Chen, C.K. Gelbke, T. Nayak, J. Pochodzalla, F. Zhu, M. Tohyama, W. Trautmann et al., Phys. Rev. Lett. 60 (1988) 1479
- 1988VA03 A.G.M. van Hees, A.A. Wolters and P.W.M. Glaudemans, Nucl. Phys. A476 (1988) 61
- 1988WA18 A.H. Wapstra, G. Audi and R. Hoekstra, At. Data Nucl. Data Tables 39 (1988) 281

- 1988WO04 A.A. Wolters, A.G.M. van Hees and P.W.M. Glaudemans, *Europhys. Lett.* 5 (1988) 7
- 1988ZVZZ A.G. Zvenigorodsky, S.N. Abramovich, B.Ya. Guzhovsky and O.A. Pelipenko, in *Baku* (1988) 297
- 1990AJ01 F. Ajzenberg-Selove, *Nucl. Phys.* A506 (1990) 1