

Energy Levels of Light Nuclei $A = 7$

F. Ajzenberg-Selove

University of Pennsylvania, Philadelphia, Pennsylvania 19104-6396

Abstract: An evaluation of $A = 5-10$ was published in *Nuclear Physics A490* (1988), p. 1. This version of $A = 7$ differs from the published version in that we have corrected some errors discovered after the article went to press. The introduction and introductory tables have been omitted from this manuscript. [Reference](#) key numbers have been changed to the NNDC/TUNL format.

(References closed June 1, 1988)

The original work of Fay Ajzenberg-Selove was supported by the US Department of Energy [DE-FG02-86ER40279]. Later modification by the TUNL Data Evaluation group was supported by the US Department of Energy, Office of High Energy and Nuclear Physics, under: Contract No. DEFG05-88-ER40441 (North Carolina State University); Contract No. DEFG05-91-ER40619 (Duke University).

Table of Contents for $A = 7$

Below is a list of links for items found within the PDF document. The introductory [Table 2](#) is available on this website via the link.

A. Nuclides: [\${}^7\text{H}\$](#) , [\${}^7\text{He}\$](#) , [\${}^7\text{Li}\$](#) , [\${}^7\text{Be}\$](#) , [\${}^7\text{B}\$](#)

B. Tables of Recommended Level Energies:

[Table 7.1](#): Energy levels of ${}^7\text{He}$

[Table 7.2](#): Energy levels of ${}^7\text{Li}$

[Table 7.7](#): Energy levels of ${}^7\text{Be}$

C. [References](#)

D. Figures: [\${}^7\text{Li}\$](#) , [\${}^7\text{Be}\$](#) , [Isobar diagram](#)

E. Erratum to this Publication: [PS](#) or [PDF](#)

${}^7\text{H}$

(Not illustrated)

${}^7\text{H}$ has not been observed. Attempts have been made to detect it in the spontaneous fission of ${}^{252}\text{Cf}$ (1982AL33) and in the ${}^7\text{Li}(\pi^-, \pi^+)$ reaction [see (1984AJ01)]. The ground state is calculated to have $J^\pi = \frac{1}{2}^+$ and to be unstable with respect to 1n, 2n, 3n and 4n emission. Excited states are predicted at 4.84, 5.00 and 6.96 MeV, with $J^\pi = \frac{3}{2}^+$, $\frac{5}{2}^+$, and $\frac{5}{2}^-$ [(0 + 1) $\hbar\omega$ model space] and at 3.88, 3.94 and 5.99 MeV with $J^\pi = \frac{3}{2}^+$, $\frac{5}{2}^+$ and $\frac{1}{2}^+$ [(0 + 2) $\hbar\omega$ model space] (1985PO10). See also (1984BE1C, 1987FL1A, 1987GOZN, 1987PE1C) and (1985GA1C, 1986GA33; theor.).

${}^7\text{He}$

(Fig. 3)

GENERAL: See also (1984AJ01).

Hypernuclei: (1982KA1D, 1983FE07, 1984AS1D, 1985KO1G, 1986DA1B, 1986DO01, 1986ME1F).

Other topics: (1983ANZQ, 1984FR13, 1984VA06, 1986GI10, 1986SH1L, 1987BO40, 1987GOZN, 1987PE1C).

Mass of ${}^7\text{He}$: The atomic mass excess of ${}^7\text{He}$ is 26.11 ± 0.03 MeV: ${}^7\text{He}$ is then unbound with respect to decay into ${}^6\text{He} + \text{n}$ by 0.44 MeV: see (1984AJ01). The ground state is calculated to have $J^\pi = \frac{3}{2}^-$ and to be unstable with respect to decay into ${}^6\text{He} + \text{n}$ by about 1 MeV (1985PO10). [I am indebted to F.C. Barker for his comments.] See also (1987BEYI).

1. ${}^7\text{Li}(\pi^-, \gamma){}^7\text{He}$ $Q_m = 128.37$

Capture γ -rays from the transition to ${}^7\text{He}_{\text{g.s.}}$ are reported by (1986PE05).

2. ${}^7\text{Li}(\text{n}, \text{p}){}^7\text{He}$ $Q_m = -10.42$

The proton group corresponding to ${}^7\text{He}_{\text{g.s.}}$ has $\Gamma < 0.2$ MeV: see (1979AJ01). At $E_n = 60$ MeV broad bumps in the spectra are ascribed to states at $E_x \approx 20 \pm 1$ MeV [$\Gamma = 9 \pm 2$ MeV] and, possibly, at ≈ 6 MeV (1983BR32, 1984BR03) [see for discussion of the GDR]. See also (1987HE24) and (1987BR32).

3. ${}^7\text{Li}(\text{t}, {}^3\text{He}){}^7\text{He}$ $Q_m = -11.18$

Table 7.1: Energy levels of ${}^7\text{He}$ ^a

E_x (MeV) ^b	$J^\pi; T$	$\Gamma_{\text{c.m.}}$ (keV)	Decay	Reactions
g.s.	$(\frac{3}{2})^-; \frac{3}{2}$	160 ± 30	n	1, 2, 3, 4

^a Excited states are calculated at 4.27, 4.55 and 5.38 MeV with $J^\pi = \frac{1}{2}^-, \frac{1}{2}^+$ and $\frac{5}{2}^-$ [(0 + 1) $\hbar\omega$ model space]. In the (0 + 2) $\hbar\omega$ model space the excited states are at 3.43, 5.03 and 7.47 MeV with $J^\pi = \frac{1}{2}^-, \frac{5}{2}^-$ and $\frac{3}{2}^-$ (1985PO10).

^b See also reactions 2 and 4, and the preliminary reports in (1987BEYI, 1987BO40).

The ${}^3\text{He}$ particles to the ground state of ${}^7\text{He}$ have been observed at $E_t = 22$ MeV. The width of the ground state is 160 ± 30 keV; for a radius of 2.2 fm and $l_n = 1$, this width is 0.22 of the Wigner limit. The angular distribution is peaked in the forward direction. No other states of ${}^7\text{He}$ were observed for $E_x < 2.4$ MeV: see (1979AJ01).

4. (a) ${}^7\text{Li}({}^7\text{Li}, {}^7\text{Be}){}^7\text{He}$	$Q_m = -12.07$
(b) ${}^7\text{Li}({}^{11}\text{B}, {}^{11}\text{C}){}^7\text{He}$	$Q_m = -13.19$
(c) ${}^9\text{Be}({}^6\text{Li}, {}^8\text{B}){}^7\text{He}$	$Q_m = -23.60$
(d) ${}^9\text{Be}({}^9\text{Be}, {}^{11}\text{C}){}^7\text{He}$	$Q_m = -14.07$
(e) ${}^9\text{Be}({}^{11}\text{B}, {}^{13}\text{N}){}^7\text{He}$	$Q_m = -11.44$
(f) ${}^9\text{Be}({}^{14}\text{C}, {}^{16}\text{O}){}^7\text{He}$	$Q_m = -7.01$

At $E({}^6\text{Li}) = 72$ MeV and at $E({}^7\text{Li}) = 70$ MeV (reactions (a) and (c)) there is no evidence for excited states with $\Gamma \leq 2$ MeV for $E_x < 10$ MeV (1985AL1G, 1985AL29, 1985ALZL, 1985ALZM). The ground state of ${}^7\text{He}$ is strongly populated. Reactions (b), (d), (e) and (f) have been investigated at $E({}^{11}\text{B}) = 88$, $E({}^9\text{Be}) = 106.7$ and $E({}^{14}\text{C}) = 152.6$ MeV. The ground state of ${}^7\text{He}$ is populated. There is some evidence for a second state in reaction (f) at $E_x = 2.9 \pm 0.5$, $\Gamma = 1.5 \pm 0.5$ MeV (1987BEYI). See also (1979AJ01) and (1988BEYJ).

${}^7\text{Li}$
(Figs. 1 and 3)

GENERAL: See also (1984AJ01).

Shell model: (1983BU1B, 1983KU17, 1983SH1D, 1983VA31, 1984CH24, 1984REZZ, 1984VA06, 1984ZW1A, 1985FI1E, 1985GO11, 1986AV08, 1987KA09, 1987KI1C, 1988WO04).

Cluster and α -particle models: (1981PL1A, 1983FU1D, 1983HO22, 1983PA06, 1983SH1D, 1983SR1C, 1984BA53, 1984DA07, 1984DU13, 1984DU17, 1984JO1A, 1984KA06, 1984KA04, 1984LO09, 1984MI1F, 1984SH26, 1985FI1E, 1985FU01, 1985FU11, 1985KW02, 1985WA17, 1986AV08, 1986FA11, 1986FI07, 1986KR12, 1986SA15, 1986SA1D, 1986VA13, 1987BA1I, 1987IM04, 1987KA09, 1987LE33, 1987TA06, 1987ZH1E, 1988US1A).

Special states: (1981PL1A, 1982PO12, 1983BU1B, 1983FI11, 1983HO22, 1983KU17, 1983VA31, 1984DU13, 1984DU17, 1984FI20, 1984OH01, 1984REZZ, 1984VA06, 1984VAZS, 1984ZW1A, 1985BA68, 1985FI1E, 1985GO11, 1985GO1A, 1986BA2J, 1986FI07, 1986SA15, 1986VA13, 1987KI1C, 1987SV1A, 1987WA36, 1987ZH1E, 1988KW02, 1988US1A, 1988ZH1B).

Electromagnetic transitions, giant resonances: (1983FI11, 1983GM1A, 1983KU17, 1984CH24, 1984DU17, 1984KA06, 1984KA04, 1984MO1D, 1984SH26, 1985FI1E, 1985GO23, 1985GO1A, 1985WA17, 1986ER1A, 1986FI07, 1986ME13, 1986VA13, 1987AR1E, 1987KI1C, 1987LE33, 1987ZH1E).

Astrophysical questions: (1982AU1A, 1982CA1A, 1982GR1A, 1982WA1B, 1983SI1B, 1983WA1H, 1984RA1E, 1984TR1C, 1984YA1A, 1985BO1E, 1985BO1K, 1985DE1E, 1985DE1K, 1985GI1C, 1985HO1A, 1985MI1E, 1985SC1C, 1985SC1D, 1985WA1K, 1986BO1H, 1986MA1U, 1986ME13, 1986PA1H, 1986RE1C, 1986RO1P, 1986SA1G, 1986SH1G, 1986SP1A, 1986WI1D, 1987AR1J, 1987AR1C, 1987AU1E, 1987CO1X, 1987DO1H, 1987DU1C, 1987FO1B, 1987HO1M, 1987KA1R, 1987KA1V, 1987MAZC, 1987MA2C, 1987PA1F, 1987RA1D, 1987RE1F, 1987RO25, 1987SP1C, 1987SP1D, 1988BA86, 1988KAZY, 1988KA07, 1988KA1H, 1988MEZS, 1988RE1B).

Complex reactions involving ${}^7\text{Li}$: (1982GU21, 1983CH23, 1983EF1A, 1983GU1A, 1983GU1B, 1983KH04, 1983KU1B, 1983LE1F, 1983MA53, 1983MU08, 1983NA08, 1983OL1A, 1983SI1A, 1983SO08, 1983ST1A, 1983UT01, 1984AI1A, 1984BE1E, 1984DA07, 1984EC01, 1984GR08, 1984HI1A, 1984IS02, 1984MO29, 1984RE14, 1984SH17, 1984SI15, 1984ST1B, 1984XI1B, 1985AG1A, 1985BH02, 1985FA02, 1985GL06, 1985GO20, 1985KI1C, 1985MA02, 1985MA13, 1985MC03, 1985MO17, 1985MO24, 1985SH1G, 1985WA1F, 1985WA22, 1985WO11, 1986AV1A, 1986BL12, 1986DAZP, 1986GL1E, 1986GO1F, 1986HA1B, 1986JO1A, 1986KA1C, 1986KA1G, 1986KO1L, 1986ME06, 1986MO1E, 1986NAZV, 1986RE13, 1986SAZL, 1986SA30, 1986SA1N, 1986SHZO, 1986SH1F, 1986SIZS, 1986SO10, 1986TA1F, 1986TA1G, 1986TA1M, 1986TU1A, 1986TU01, 1986WA1H, 1986WE1C, 1986YA1L, 1987AK1A, 1987AU1C, 1987BA38, 1987BE58, 1987BL13, 1987CH26, 1987COZZ, 1987DE37, 1987DO02, 1987FA02, 1987FE1A, 1987GL05, 1987GO17, 1987GR11, 1987HE1H, 1987JA06, 1987KI05, 1987KIZY, 1987MU03, 1987MU1D, 1987NA01, 1987NI04, 1987PO23, 1987SA04, 1987SH23, 1987SI1C, 1987SO13, 1987SO15,

1987ST01, 1987TAZU, 1987TE1D, 1987TR05, 1987WA09, 1987YA16, 1988BL09, 1988CA06, 1988CEZZ, 1988GO1H, 1988KA1L, 1988KI05, 1988KW02, 1988RU01, 1988SA19, 1988SH1E, 1988SH20, 1988ST06, 1988TA1A, 1988VA1E).

Polarization of ${}^7\text{Li}$: (1983HA1H, 1984JO1A, 1984NI01, 1985TU1A, 1985WE08, 1986CH1Q, 1986FR03, 1986ME13, 1986NO1C, 1986SA15, 1986ST1E, 1986TA1G, 1986TU01, 1987AR1E, 1987FI1D, 1987KA1I, 1987KA1V, 1987MU04, 1987SA04, 1988GR07, 1988KA02).

Applications: (1983AM1A, 1983AS03, 1983FI1C, 1983KU1C, 1984CA1D, 1984SA1E, 1984XI1A, 1985AD1B, 1985PA1A, 1986AU1A, 1986BE1J, 1986EN1A, 1986FI1D, 1986KL1B, 1986KR1C, 1986LI1J, 1986MA1S, 1986RA1D, 1986SA1M, 1986SC35, 1986ST1E, 1986ZA1C).

Muon and neutrino capture and reactions: (1983GM1A, 1984RO1B, 1985MAZZ, 1985RU01, 1986MA16, 1987KU23, 1987SU06, 1988AL1H).

Pion capture and reactions involving pions: (1982BA60, 1983AB1B, 1983AS1B, 1983AS1C, 1983BA26, 1983BA1A, 1983BA1G, 1983GE12, 1983GM1A, 1983HE17, 1983KA19, 1983PE14, 1983RA1D, 1983SE16, 1983SP06, 1984ABZY, 1984BA1T, 1984BA1U, 1984BO1H, 1984BU1D, 1984HU1C, 1984JI03, 1984ZA1A, 1985LA20, 1985IR01, 1985MO1F, 1986AN40, 1986AV08, 1986BA1C, 1986CE04, 1986CHIP, 1986DO01, 1986ER1A, 1986KA1J, 1986MO1J, 1986PA12, 1986PE05, 1986PR01, 1986RO03, 1986YO06, 1986ZO1A, 1987BA2F, 1987CH1D, 1987MA1I, 1987ROZY, 1988GIZU, 1988POZS).

Reactions involving kaons and other mesons: (1983BA71, 1983FE07, 1983GE13, 1983GE1C, 1984BA1M, 1984BO1H, 1984CH1H, 1984MO09, 1985GA1C, 1985KN1A, 1985MO1F, 1986BA1W, 1986CH1P, 1986DO01, 1986GA1H, 1986GA33, 1986HU1B, 1986KA1J, 1986MA1C, 1986MO1J, 1986ZO1A, 1987CH1D, 1987KN09, 1987PO1H, 1988HA44).

Reactions involving antiprotons: (1984GU06, 1985DU05, 1986DU10, 1986KO1E, 1986MO1J, 1987GR1I, 1987PO05).

Fig. 1: Energy levels of ${}^7\text{Li}$. In these diagrams, energy values are plotted vertically in MeV, based on the ground state as zero. Uncertain levels or transitions are indicated by dashed lines; levels which are known to be particularly broad are cross-hatched. Values of total angular momentum J , parity, and isobaric spin T which appear to be reasonably well established are indicated on the levels; less certain assignments are enclosed in parentheses. For reactions in which ${}^7\text{Li}$ is the compound nucleus, some typical thin-target excitation functions are shown schematically, with the yield plotted horizontally and the bombarding energy vertically. Bombarding energies are indicated in laboratory coordinates and plotted to scale in cm coordinates. Excited states of the residual nuclei involved in these reactions have generally not been shown; where transitions to such excited states are known to occur, a brace is sometimes used to suggest reference to another diagram. For reactions in which the present nucleus occurs as a residual product, excitation functions have not been shown; a vertical arrow with a number indicating some bombarding energy, usually the highest, at which the reaction has been studied, is used instead. Further information on the levels illustrated, including a listing of the reactions in which each has been observed, is contained in the master table, entitled “Energy levels of ${}^7\text{Li}$ ”.

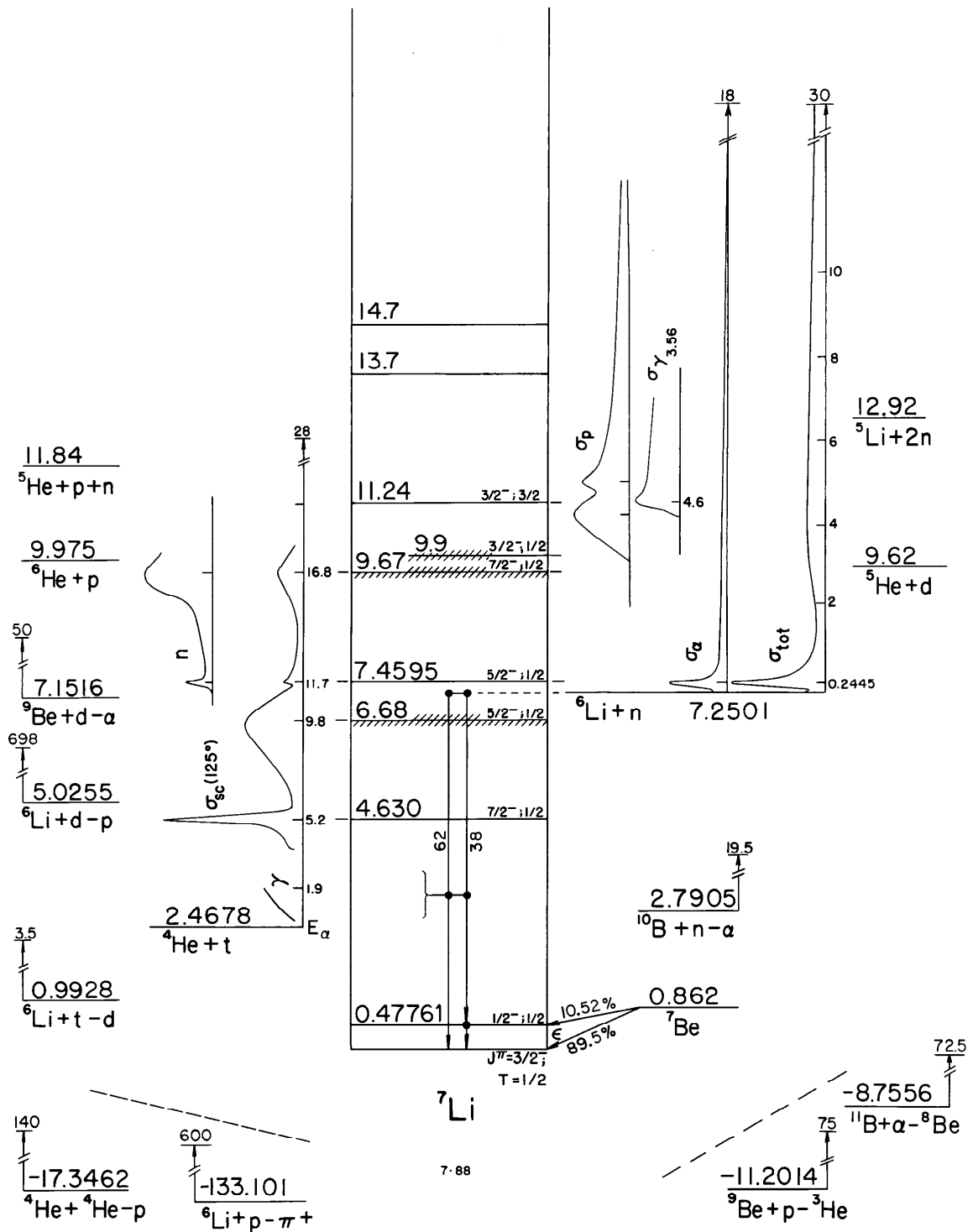

Hypernuclei: (1982KA1D, 1982MO1B, 1983BA1M, 1983FE07, 1983MA64, 1983MO1C, 1983SH38, 1983SH1E, 1984AS1D, 1984BA1M, 1984BO1H, 1984CH1G, 1984CH1H, 1984HA1D, 1984MI1C, 1984MI1E, 1984MO09, 1984MO1H, 1984SH1J, 1984ZH1B, 1985AH1A, 1985KN1A, 1985KO1G, 1985MO1F, 1986AN1R, 1986BA1W, 1986CH1P, 1986DA1B, 1986ER1A, 1986GA1H, 1986HU1B, 1986MA1C, 1986ME1F, 1986YA1F, 1987KN09, 1987MI38, 1987PO1H, 1987WA36, 1987YA1M, 1988TA29).

Other topics: (1983FU1D, 1983PA06, 1983SH1D, 1984LO09, 1984OH01, 1985AN28, 1985GO23, 1985KA01, 1985TU1A, 1986DE1J, 1986GL1A, 1986GR1A, 1987AJ1A, 1987LE33, 1987SV1A, 1988BA1R, 1988FIZT, 1988GU1C, 1988KW02).

Coulomb excitation of ${}^7\text{Li}$: (1984SH17, 1984VE03, 1984VE08, 1986FA11).

Ground-state properties of ${}^7\text{Li}$: (1983ANZQ, 1983SR1C, 1983VA31, 1984AN1B, 1984CH24, 1984DU17, 1984GE05, 1984KA06, 1984MIZM, 1984NI01, 1984OH01, 1984PE12, 1984SH26, 1984VE03, 1985AN28, 1985BU02, 1985CL1A, 1985FI1E, 1985FU11, 1985GO1A, 1985HA18, 1985KL1B, 1985SA32, 1985WA17, 1986KO1U, 1986RO03, 1986SY1A, 1987AR1E, 1987HA30, 1987KA1U, 1987KA22, 1987KI1C, 1987SV1A, 1987TR1D, 1988JO1C, 1988KA02, 1988KA07, 1988POZS, 1988TA1D, 1988VA03, 1988WO04).

$$\mu = +3.256424 \text{ (2) nm: see (1978LEZA).}$$

$Q = -40.6 \pm 0.8 \text{ mb}$ (1988DI1B). See (1988DI1B) for a review of earlier determinations, particularly those of (1984SU09, 1984VE03, 1984VE08, 1985WE08).

$B(E2): \frac{3}{2}^- \rightarrow \frac{1}{2}^- = 8.3 \pm 0.5 \text{ e}^2 \cdot \text{fm}^4$ (1985WE08). See also (1984VE08), (1988TA1D) and (1984AJ01).

Isotopic abundance: $(92.5 \pm 0.2)\%$ (1984DE53). See also (1987LA1J, 1988LA1C).

The interaction nuclear radius of ${}^7\text{Li}$ is $2.23 \pm 0.02 \text{ fm}$ (1985TA18). [See also for derived nuclear matter, charge and neutron matter r.m.s. radii].

$$1. \text{}^3\text{H}(\alpha, \gamma){}^7\text{Li} \quad Q_m = 2.4678$$

Excitation functions and angular distributions have been studied for $E_\alpha = 0.5$ to 2.0 MeV . The cross section rises smoothly as expected for a direct capture process: see (1966LA04) and (1987BU18; γ_0, γ_1). $S(E)$ and the branching ratio $\text{DC} \rightarrow 478/\text{DC} \rightarrow 0$ have been measured by (1987SC18): $S(0) = 0.14 \pm 0.02 \text{ keV} \cdot \text{b}$, including earlier measurements. Using $S(0) = 0.100 \text{ keV} \cdot \text{b}$, (1987KA1R) predict Big-Bang production of ${}^7\text{Li}$ at all relevant densities and calculate the bounds on the mass density of the Universe from the observed ${}^7\text{Li}$ abundance. For other astrophysical calculations see (1984WA11, 1984YA1A, 1985CA41, 1985DE1K, 1985KA1H, 1985KA1K, 1986KA45, 1986LA22, 1986ME13, 1988KA02, 1988KAZY, 1988KA07, 1988KA1H). See also (1984NE1B; applied) and (1984KA01; theor.).

Table 7.2: Energy levels of ${}^7\text{Li}$

E_x (MeV \pm keV)	$J^\pi; T$	τ_m or $\Gamma_{c.m.}$ (keV)	Decay	Reactions
g.s.	$\frac{3}{2}^-; \frac{1}{2}$		stable	1, 2, 4, 5, 6, 10, 11, 12, 13, 14, 15, 16, 17, 18, 19, 20, 21, 22, 23, 24, 25, 26, 27, 28, 29, 30, 31, 32, 33, 34, 35, 36, 37, 38, 39, 40, 41, 42, 43, 44, 45, 46, 47, 48, 49
0.477612 ± 0.003	$\frac{1}{2}^-; \frac{1}{2}$	$\tau_m = 105 \pm 3$ fsec ^a	γ	4, 5, 6, 10, 11, 14, 15, 16, 17, 18, 19, 20, 21, 24, 25, 30, 31, 32, 33, 34, 35, 36, 37, 39, 40, 41, 42, 43, 44, 46, 47, 48, 49
4.630 ± 9	$\frac{7}{2}^-; \frac{1}{2}$	$\Gamma = 93 \pm 8$ keV	t, α	3, 4, 10, 11, 15, 16, 17, 18, 19, 20, 21, 25, 34, 35, 37, 42, 45
6.68 ± 50	$\frac{5}{2}^-; \frac{1}{2}$	875_{-100}^{+200}	t, α	3, 11, 15, 16, 17, 21, 35, 42, 48
7.4595 ± 1.0	$\frac{5}{2}^-; \frac{1}{2}$	89 ± 7	n, t, α	2, 3, 7, 8, 9, 11, 15, 16, 17, 18, 21, 32, 34, 35, 42
9.67 ± 100	$\frac{7}{2}^-; \frac{1}{2}$	≈ 400	n, t, α	2, 3, 11, 16, 18, 21, 35
9.85	$\frac{3}{2}^-; \frac{1}{2}$	≈ 1200	n, α	7, 32
11.24 ± 30	$\frac{3}{2}^-; \frac{3}{2}$	260 ± 35	n, p	7, 8, 34
13.7		≈ 500	n	13
14.7^b		≈ 700	n	13

^a See Table 7.2 in (1979AJ01), Table 7.5 here and reaction 35.

^b See also reactions 7, 9, 13, 20 and 33 for possible additional states.

Table 7.3: ${}^7\text{Li}$ levels from ${}^3\text{H} + {}^4\text{He}$ ^a

E_x (MeV \pm keV)	J^π	l_α	LS term	R (fm)	θ_α^2 ^b	θ_{no}^2
4.65 \pm 20	$\frac{7}{2}^-$	3	${}^2\text{F}_{7/2}$	4.0	0.57 \pm 0.04	0.000 \pm 0.002
6.64 \pm 100	$\frac{5}{2}^-$	3	${}^2\text{F}_{5/2}$	4.0	1.36 \pm 0.13	
6.79 \pm 90	$\frac{5}{2}^-$	3	${}^2\text{F}_{5/2}$	4.4	0.52	
7.47 \pm 30	$\frac{5}{2}^-$	3	${}^4\text{P}_{5/2}$	4.0	0.011 \pm 0.001	0.26 \pm 0.02
9.67 \pm 100	$\frac{7}{2}^-$	3	${}^4\text{D}_{7/2}$	4.0	0.53 \pm 0.22	2.3 \pm 0.7 ^c

^a For references see Table 7.3 in (1979AJ01).

^b $\gamma^2/(\frac{3}{2}\hbar^2/\mu a^2)$.

^c θ_{n1}^2 to ${}^6\text{Li}^*(2.19)$.

2. ${}^3\text{H}(\alpha, n){}^6\text{Li}$

$$Q_m = -4.7823$$

$$E_b = 2.4678$$

The cross section for this reaction has been measured for $E_\alpha = 11$ to 18 MeV: the data show the effect of ${}^7\text{Li}^*(7.46)$ and indicate a broad resonance near $E_\alpha = 16.8$ MeV [${}^7\text{Li}^*(9.6)$]. The level parameters derived from this reaction and from reaction 3 are displayed in Table 7.3. The yield of ${}^6\text{Li}$ ions at 0° (lab) has also been measured for $E_\alpha = 11.310$ to 11.930 MeV with 2–3% accuracy: the data were then reduced to obtain the c.m. differential cross sections at 0° and 180° for the inverse reaction in the energy region corresponding to formation of ${}^7\text{Li}^*(7.46)$: see (1979AJ01). See also (1985CA41; astrophys.).

3. ${}^3\text{H}(\alpha, \alpha){}^3\text{H}$

$$E_b = 2.4678$$

The excitation curves for the elastic scattering show the effects of ${}^7\text{Li}^*(4.63, 6.68, 7.46, 9.67)$. The derived level parameters are displayed in Table 7.3. Angular distributions have been studied for $E_\alpha = 2.13$ to 2.98 MeV and $E_t = 6.0$ to 17 MeV [see (1979AJ01, 1984AJ01)] and at $E_\alpha = 56.3$ to 95.5 MeV (1986YA1M; prelim.; also A_y). A polarization extremum ($A_y = -1$) occurs near $E_t = 11.1$ MeV, $\theta = 95^\circ$: see (1984AJ01). For the breakup of ${}^7\text{Li}$ into $\alpha + t$ in various processes see (1984AJ01) and (1984SH17, 1987FO08, 1987PO03) as well as ‘‘Complex reactions’’ on p. 54. For cross section calculations from an R -matrix calculation see (1987KN04).

For muon catalysis see (1984KR1B). See also (1981PL1A, 1983FI09, 1983FU11, 1983FU19, 1983HAYX, 1983LO09, 1984DU13, 1984FI20, 1984FU04, 1984HO1C, 1984KA01, 1984KR10, 1984LO1C, 1985FU01, 1985FU11, 1985SH22, 1986BA2J, 1986BO01, 1986KA30, 1986SA1D, 1988FIZT; theor.).

4. ${}^4\text{He}({}^3\text{He}, \pi^+){}^7\text{Li}$

$$Q_m = -137.119$$

${}^7\text{Li}^*(0 + 0.48, 4.63)$ have been populated at $E({}^3\text{He}) = 266.5$ and 280.5 MeV: see (1984AJ01). See also (1984GE05, 1987KA09; theor.).

5. ${}^4\text{He}(\alpha, p){}^7\text{Li}$ $Q_m = -17.3462$

Angular distributions have been reported at $E_\alpha = 39.9$ to 140 MeV [see (1979AJ01, 1984AJ01)] and at 61.5 to 158.2 MeV (1982GL01) and 198.4 MeV (1985WO11) for the transitions to ${}^7\text{Li}^*(0, 0.48)$. See (1982GL01, 1985WO11) for a discussion of ${}^7\text{Li}$ production in the Big Bang. See also ${}^8\text{Be}$ and (1986KA26; theor.).

6. ${}^6\text{Li}(n, \gamma){}^7\text{Li}$ $Q_m = 7.2501$

$$Q_0 = 7251.02 \pm 0.09 \text{ keV (1985KO47)}$$

The thermal capture cross section is 38.5 ± 3.0 mb (1981MUZQ). Gamma rays are observed corresponding to transitions to ${}^7\text{Li}^*(0, 0.48)$ with branching ratios (62 ± 2) and $(38 \pm 2)\%$ (1985KO47). ${}^7\text{Li}^*(4.63, 6.68)$ are not populated [$\leq 5\%$] (1985KO47). See (1979AJ01) for the earlier work. See also (1986AB1E). The decay of ${}^7\text{Li}^*(7.46) \rightarrow {}^6\text{Li}_{\text{g.s.}} + n$ in the interaction of $35 \text{ MeV}/A$ ${}^{14}\text{N}$ ions on Ag is reported by (1987BL13).

7. ${}^6\text{Li}(n, n){}^6\text{Li}$ $E_b = 7.2501$

The real coherent scattering length is 2.0 ± 0.1 fm; the complex scattering lengths are $b_+ = (0.67 \pm 0.14) - i(0.08 \pm 0.01)$ fm, $b_- = (4.67 \pm 0.17) - i(0.62 \pm 0.02)$ fm; $\sigma_{\text{free}} = 0.70 \pm 0.01$ b (1983KO17). See also (1979GL12). (1983AL1E) report σ_s (below 10 keV) = 0.72 ± 0.02 b. See also (1981MUZQ). The total cross section has been measured from $E_n = 4$ eV to 49.6 MeV [see (1976GAYV, 1984AJ01)], at 0.6 to 80 keV (1982AL35) and at 0.08 to 3.0 MeV (1983KN1D; prelim.).

A pronounced resonance occurs at $E_n = 244.5 \pm 1.0$ keV [$E_x = 7459.5 \pm 1.0$ keV] with a peak cross section of 11.2 ± 0.2 b (1982SM02): see Table 7.4. No other clearly defined resonance is observed to $E_n = 49.6$ MeV although the total cross section exhibits a broad maximum at $E_n \approx 4.5$ MeV: see (1984AJ01). The analyzing power has been measured for $E_n = 1.48$ to 5 MeV [see (1984AJ01)] and 5 to 17 MeV (1986PF1A; prelim.). Recent multi-level, multi-channel R -matrix analyses (1987KN04, 1983KN06) for $E_n \leq 8$ MeV [using also data from other channels] include 13 normal and 14 non-normal parity states with $E_x \leq 17$ MeV. [Only ten states have been seen directly in reaction or compound nucleus cross-section work.] Two positive-parity states provide an explanation for the anisotropy of the ${}^6\text{Li}(n, \alpha)$ work at low energies (1983KN06). For

Table 7.4: Resonance parameters for 7.5 – 7.2 MeV levels in ${}^7\text{Li}$ and ${}^7\text{Be}$ ^a

Reaction	${}^6\text{Li} + \text{n}$	${}^6\text{Li} + \text{p}$
E_r (keV, lab)	262 ^b	1840
$\Gamma(E_r)$ (keV, c.m.)	154	836
E_λ (keV above g.s.)	7700	7580
$\Gamma_{\text{n,p}}(E_r)$ (keV, c.m.)	118	798
radius (n, p) in fm	3.94	4.08
$\gamma_{\text{n,p}}^2$ (MeV · fm)	4.85	5.02
$\theta_{\text{n,p}}^2$	0.26	0.28
$\Gamma_\alpha(E_r)$ (keV, c.m.)	36	38
radius (α) in fm	4.39	4.39
γ_α^2 (MeV · fm)	0.101	0.101
θ_α^2	0.012	0.012

^a These states are believed to have a ${}^4\text{P}_{5/2}$ character, consistent with their large θ_{n}^2 and θ_{p}^2 . For references see Table 7.4 in (1979AJ01).

^b 244.5 ± 1.0 keV (1982SM02).

the results of an earlier R -matrix analysis see (1984AJ01). Cross sections for n_0 and n_1 have also been measured at $E_n = 7.75$ and 8.90 MeV (1987SC08).

The excitation function for 3.56 MeV γ -rays exhibits an anomaly, also seen in the (n, p) reaction (reaction 8). The data are well fitted assuming $E_{\text{res}} = 3.50$ and 4.60 MeV [$E_x = 10.25 \pm 0.10$ and 11.19 ± 0.05 MeV], $T = \frac{1}{2}$ and $\frac{3}{2}$, $\Gamma_{\text{c.m.}} = 1.40 \pm 0.10$ and 0.27 ± 0.05 MeV, respectively; both $J^\pi = \frac{3}{2}^-$: see (1979AJ01) for a discussion of these and other (unpublished) data.

See also ${}^6\text{Li}$, (1984FE1A, 1985CH37, 1986DR10), (1983DA22, 1983GO1H, 1984SH1C, 1988MA1H), (1986BOZG; applications) and (1981PL1A, 1983FA17, 1983FU11, 1983FU19, 1984FU04, 1984WA1H, 1985FU01, 1985LI1F; theor.).

$$\begin{array}{lll}
 8. \text{ (a) } {}^6\text{Li}(\text{n}, 2\text{n}){}^5\text{Li} & Q_{\text{m}} = -5.67 & E_{\text{b}} = 7.2501 \\
 \text{ (b) } {}^6\text{Li}(\text{n}, \text{p}){}^6\text{He} & Q_{\text{m}} = -2.725 & \\
 \text{ (c) } {}^6\text{Li}(\text{n}, \text{d}){}^5\text{He} & Q_{\text{m}} = -2.37 &
 \end{array}$$

For reaction (a) see (1985CH37, 1986CH24). The excitation function for reaction (b), measured from threshold to $E_n = 8.9$ MeV, exhibits an anomaly at $E_n = 4.6$ MeV. The excitation function, at forward angles, of p_0 is approximately constant for $E_n = 4.4$ to 7.25 MeV: see (1979AJ01).

The excitation function, at forward angles, of deuterons (reaction (c)) increases monotonically for $E_n = 5.4$ to 6.8 MeV: see (1979AJ01). See also ^5He , ^6He , (1986WAZY), (1984SH1C, 1986AU1D, 1988MA1H), (1986BOZG; applications) and (1987KN04; theor.).

9. $^6\text{Li}(n, \alpha)^3\text{H}$

$$Q_m = 4.7821$$

$$E_b = 7.2501$$

The isotopic thermal cross section is 940 ± 4 b: see (1981MUZQ). See also (1985SW01). A resonance occurs at $E_n = 241 \pm 3$ keV with $\sigma_{\text{max}} = 3.3$ b: see (1986CA28, 1984AJ01). The resonance is formed by p-waves, $J^\pi = \frac{5}{2}^-$, and has a large neutron width and a small α -width: see Table 7.4. Above the resonance the cross section decreases monotonically to $E_n = 18.2$ MeV, except for a small bump near $E_n \approx 1.8$ MeV and an inflection near $E_n = 3.5$ MeV. For a description of R -matrix analyses which suggest the location of higher states of ^7Li , see reaction 7 and (1984AJ01), as well as (1987KN04).

Angular distributions have been measured at many energies in the range $E_n = 0.1$ to 14.1 MeV [see (1979AJ01, 1984AJ01)] as well as at 35 eV to 325 keV (1983KN03) and 2.16 to 4.20 , 7.1 and 13.7 MeV (1986BA32, 1986BA68). Polarization measurements have been reported for $E_n = 0.2$ to 2.4 MeV: the data suggest interference between s-waves and the p-wave resonance at 0.25 MeV. Interference between this $\frac{5}{2}^-$ state and a broad $\frac{3}{2}^-$ state 2 MeV higher also appears to contribute. At the higher energies A_y is close to $+0.9$ near 90° and varies slowly with E_n : see (1979AJ01). See also (1983VE10, 1984VEZW).

For a study of coincidences in the $^6\text{Li}(n, \alpha d)n$ reaction see (1986MI11). The triton production cross section at $E_n = 14.92$ MeV is 32 ± 3 mb (1985GO18). The total α production cross section [which includes the (n, nd) process] at $E_n = 14.95$ MeV is 512 ± 26 mb (1986KN06).

See also (1983AS1D, 1983CO1E, 1986CA29), (1984SH1C, 1985BO1D, 1986MI1G), (1984YA1A; astrophysics), (1984XIIA, 1985GO18, 1986BA2N, 1986BOZG, 1986BR1L, 1986CH1S, 1986CO1H, 1986FA13, 1986GO1K, 1986GR1F, 1986MA1R, 1986PE1K, 1986SA1R, 1986SA1H, 1986SE1D, 1986SU1J, 1986TA1H, 1986VE1A, 1986WI1B; applications) and (1986HA45; theor.).

10. $^6\text{Li}(p, \pi^+)^7\text{Li}$

$$Q_m = -133.101$$

At $E_p = 600$ MeV, the reaction preferentially excites $^7\text{Li}^*(4.63)$. Angular distributions have been obtained for the pions to $^7\text{Li}^*(0, 0.48, 4.63)$ at $E_p = 600$ and 800 MeV. $^7\text{Li}^*(11.24)$ [$T = \frac{3}{2}$] is not observed: see (1984AJ01). Recently $\sigma(\theta)$ and A_y measurements were reported at $E_p = 800$ MeV (1987SO1C; prelim.). See also (1985LE19).

11. $^6\text{Li}(d, p)^7\text{Li}$

$$Q_m = 5.0255$$

Angular distributions of proton groups have been studied for $E_d = 0.12$ to 15 MeV and at 698 MeV: see (1966LA04, 1974AJ01, 1979AJ01, 1984AJ01). J^π of ${}^7\text{Li}^*(0.48)$ is $\frac{1}{2}^-$. The two higher states have $E_x = 4630 \pm 9$ and 7464 ± 10 keV, $\Gamma_{\text{c.m.}} = 93 \pm 8$ and 91 ± 8 keV. The breakup reactions involve ${}^7\text{Li}^*(4.63, 7.46)$ and possibly ${}^7\text{Li}^*(9.6)$ [$\Gamma = 0.5 \pm 0.1$ MeV]: see (1979AJ01). See also ${}^8\text{Be}$ and (1988KO1C).

12. ${}^6\text{Li}({}^6\text{Li}, {}^5\text{Li}){}^7\text{Li}$ $Q_m = 1.58$

See (1987MI34) and ${}^5\text{Li}$.

13. (a) ${}^7\text{Li}(\gamma, n){}^6\text{Li}$ $Q_m = -7.2501$
 (b) ${}^7\text{Li}(\gamma, 2n){}^5\text{Li}$ $Q_m = -12.92$
 (c) ${}^7\text{Li}(\gamma, p){}^6\text{He}$ $Q_m = -9.975$
 (d) ${}^7\text{Li}(\gamma, pn){}^5\text{He}$ $Q_m = -11.84$
 (e) ${}^7\text{Li}(\gamma, d){}^5\text{He}$ $Q_m = -9.62$
 (f) ${}^7\text{Li}(\gamma, t){}^4\text{He}$ $Q_m = -2.4678$

The total photoneutron cross section rises sharply from 10 MeV to reach a broad plateau at about 15 mb from 14 to 20 MeV, decreases more slowly to about 0.5 mb at 25 MeV and then decreases further to about 0.3 mb at $E_\gamma = 30$ MeV (monoenergetic photons): there are indications of weak structure through the entire region: see (1979AJ01) and (1988DI02). [I am indebted to Prof. B.L. Berman for his comments.] A recent study by (1986SI18; $E_{\text{b.s.}}$) reports evidence for the excitation of ${}^7\text{Li}^*(7.46)$, as well as of states at $E_x = 13.75 \pm 0.03$ and 14.65 ± 0.03 MeV with $\Gamma \approx 500$ and 700 keV [and integrated cross sections of ≈ 0.14 and 0.17 MeV \cdot mb], in addition to a major broad structure at 17 MeV. The integrated cross section to 23 MeV is 39 ± 4 MeV \cdot mb for the n_0 transition and 17 ± 4 MeV \cdot mb for the n_1 transition: together these account for 0.4 of the exchange augmented dipole sum of ${}^7\text{Li}$: see (1979AJ01). The integrated cross section for formation of ${}^6\text{Li}^*(3.56)$ is 4 ± 1 MeV \cdot mb to 30 MeV and 11 ± 3 MeV \cdot mb to 55 MeV: see (1984AJ01).

The total absorption cross section for *natural* Li in the range 10 to 340 MeV shows a broad peak at ≈ 30 MeV ($\sigma_{\text{max}} \approx 3$ mb), a minimum centered at ≈ 150 MeV at ≈ 0.3 mb and a fairly smooth increase in cross section to ≈ 3 mb at ≈ 320 MeV: see (1984AJ01).

The cross section for the (γ, p) reaction (reaction (c)) shows a maximum at ≈ 15.6 MeV with a width of ≈ 4 MeV. It then decreases fairly smoothly to 27 MeV. The integrated cross section for 11 \rightarrow 28 MeV is 13.2 ± 2.0 MeV \cdot mb: see (1974AJ01, 1979AJ01, 1984AJ01). Differential cross sections for the $(\gamma, n_0 + n_2)$ and (γ, p_0) processes are reported by (1983SE07, 1985SE17; $E_\gamma = 48$ to 141 MeV). Reaction (e) has been studied in the giant resonance region with $E_{\text{bs}} \leq 30$ MeV. Deuteron groups to ${}^5\text{He}_{\text{g.s.}}$ and possibly to the first excited state are reported. States of ${}^7\text{Li}$ with

$E_x = 25\text{--}30$ MeV may be involved when $E_{\text{bs}} = 37$ to 50 MeV is used: see (1979AJ01). At $E_\gamma = 0.9$ GeV, (1985RE1A) have studied π^- emission with the population of ${}^6\text{Li}^*(2.19)$.

The cross section for reaction (f) at 90° displays a broad resonance at $E \approx 7.7$ MeV ($\Gamma = 7.2$ MeV) with an integrated cross section of 6.2 MeV \cdot mb, a plateau for $12 \rightarrow 22$ MeV (at ≈ 0.6 the cross section at 7.7 MeV) and a gradual decrease to 48 MeV. The (γ, t) cross section integrated from threshold to 50 MeV is 8.1 MeV \cdot mb: see (1984AJ01), and (1986VO20). See also (1985HA1H, 1986GO1M) and (1983BE45, 1983BO1B, 1983BU1A, 1983SR1B, 1984KR10, 1985GO1A, 1985ST1A, 1986AH03, 1986BA2G, 1987BU04, 1987KA1V, 1987KI1C, 1987KO43, 1987LU1B, 1987VA05, 1988SH20; theor.).

14. ${}^7\text{Li}(\gamma, \gamma){}^7\text{Li}$

See Table 7.4 in (1966LA04) [summary of early measurements] for τ_m of ${}^7\text{Li}^*(0.48) = 107 \pm 5$ fsec. See also (1984AJ01), (1987BE1K) and (1986DU03; theor.).

15. (a) ${}^7\text{Li}(e, e){}^7\text{Li}$

(b) ${}^7\text{Li}(e, ep){}^6\text{He}$ $Q_m = -9.975$

(c) ${}^7\text{Li}(e, en){}^6\text{Li}$ $Q_m = -7.2501$

The electric form factor measurements for $E_e = 100$ to 600 MeV are well accounted for by a approxle harmonic-oscillator shell model with a quadrupole contribution described by an undeformed p-shell: $r_{\text{r.m.s.}} = 2.39 \pm 0.03$ fm, $|Q| = 42 \pm 2.5$ mb. From results obtained for $E_e = 24.14$ to 97.19 MeV, $r_{\text{r.m.s.}} = 2.35 \pm 0.10$ fm (model independent), 2.29 ± 0.04 fm (shell model). A study of the ratio of the electric charge scattering from ${}^6\text{Li}$ and from ${}^7\text{Li}$ as a function of (momentum transfer)² yields $\langle r^2 \rangle_6^{1/2} / \langle r^2 \rangle_7^{1/2} = 1.001 \pm 0.008$. The r.m.s. radius of the ground state magnetization density distribution, $\langle r^2 \rangle_M^{1/2} = 2.98 \pm 0.05$ fm. See (1979AJ01) for references.

Inelastic scattering studies show peaks corresponding to ${}^7\text{Li}^*(0.48, 4.63, 6.68, 7.46)$: see (1974AJ01) and Table 7.5. Form factors for ${}^7\text{Li}^*(0, 0.48)$ have recently been studied at $E_e = 80$ to 680 MeV (1987LI1J; prelim.).

For quasi-elastic processes see (1984AJ01) and (1985SE17). See also (1983BE1A, 1987DE43) and (1984DO20, 1984DU13, 1984KA06, 1984KA04, 1984PE12, 1984SH26, 1985WA17, 1986BAYN, 1986DO11, 1986SA1D, 1987KA22, 1987SA1C, 1988BO05; theor.).

16. ${}^7\text{Li}(\pi, \pi){}^7\text{Li}$

${}^7\text{Li}^*(0, 0.48, 4.63, 6.68, 7.46, 9.67)$ have been populated in this reaction. Angular distributions have been measured at $E_{\pi^+} = 49.7$ MeV and $E_{\pi^\pm} = 143$ and 164.4 MeV: see (1984AJ01).

Table 7.5: Levels of ${}^7\text{Li}$ from ${}^7\text{Li}(e, e')$ ^a

E_x (MeV)	$J^\pi; T$	Γ_{γ_0} (eV)	Type
0.48	$\frac{1}{2}^-; \frac{1}{2}$	$(2.8 \pm 1.6) \times 10^{-7}$	C2
		$(6.30 \pm 0.31) \times 10^{-3}$	M1
4.63 ± 0.05 ^b	$\frac{7}{2}^-; \frac{1}{2}$		C2 ^d
6.6 ± 0.1 ^c	$\frac{5}{2}^-; \frac{1}{2}$		C2
7.5 ± 0.08	$\frac{5}{2}^-; \frac{1}{2}$	0.6 ± 0.3	C2
		0.9 ± 0.4 ^e	

^a For a summary of $B(E2\uparrow)$ measurements, see Table 7.6 in (1966LA04) and ${}^7\text{Li}$, “GENERAL” section. For references see (1979AJ01, 1984AJ01).

^b $B(E2\uparrow)[\frac{3}{2}^- \rightarrow \frac{7}{2}^-] = 17.5 e^2 \cdot \text{fm}^4$.

^c $\Gamma_{\text{c.m.}} = 875_{-100}^{+200}$ keV.

^d Purely longitudinal.

^e From ${}^7\text{Li}(\gamma, n)$. See also fit by (1980BA34).

Total and partial cross sections have been obtained for E_{π^\pm} in the range $85 \rightarrow 315$ MeV [see (1984AJ01)] and at $E_{\pi^+} = 50$ MeV (1983NA18). For the $(\pi^+, 2p)$ reaction see ${}^5\text{He}$ (1986RI01). For studies of (π^+, pd) and (π^\pm, pn) see (1986WH01) and (1986YO06), respectively. For π^+ induced fission of ${}^7\text{Li}$ see (1983BA26). See also the “General” section.

17. (a) ${}^7\text{Li}(n, n){}^7\text{Li}$

(b) ${}^7\text{Li}(n, nt){}^4\text{He}$ $Q_m = -2.4678$

Angular distributions have been measured at $E_n = 1.5$ to 18 MeV [see (1979AJ01, 1984AJ01)] and at $E_n = 5.4, 6.0, 14.2$ MeV (1985CH37; n_{0+1}, n_2), 7 to 14 MeV (1983DA22; n_0), 8.0 and 24.0 MeV (1986HAZR; n_0 and n_2 at 24 MeV; prelim.), at 8.9 MeV (1984FE1A; n_{0+1}, n_2 ; prelim.) and at 14.7 MeV (1984SH01; n_{0+1}). Reaction (b) at $E_n = 14.4$ MeV proceeds primarily via ${}^7\text{Li}^*(4.63)$ although some involvement of ${}^7\text{Li}^*(6.68)$ may also occur: see (1979AJ01). See also ${}^8\text{Li}$, (1986LI15, 1987DE14, 1987SC08) and (1985CO18; applications).

18. (a) ${}^7\text{Li}(p, p){}^7\text{Li}$

(b) ${}^7\text{Li}(p, 2p){}^6\text{He}$ $Q_m = -9.975$

(c) ${}^7\text{Li}(p, pd){}^5\text{He}$ $Q_m = -9.62$

(d) ${}^7\text{Li}(p, pn){}^6\text{Li}$ $Q_m = -7.2501$

(e) ${}^7\text{Li}(p, p\alpha){}^3\text{H}$ $Q_m = -2.4678$

Angular distributions of protons have been measured for $E_p = 1.0$ to 185 MeV [see (1974AJ01, 1984AJ01)] and at $E_p = 1.89$ to 2.59 MeV (1986SA1P; p₀; prelim.). Inelastic proton groups have been observed to ${}^7\text{Li}^*(0.48, 4.63, 7.46, 9.6)$: see (1952AJ38, 1974AJ01). Double differential cross sections for the continuum are reported at $E_p = 65$ MeV (1987TO06; prelim.).

For reaction (b) see (1984PA1B, 1985PA1B; 50–100 MeV; prelim.) and (1985BE30, 1985DO16; 1 GeV). See also ${}^6\text{He}$ and (1984AJ01). For reaction (c) see (1986WA11). For reaction (d) see (1985BE30) and ${}^6\text{Li}$. Reaction (d) has been studied at $E_p = 200$ MeV: the deuteron spectroscopic factor is close to unity and the results indicate that the deuteron cluster momentum distribution is characterized, at small momentum, by a FWHM of 140 MeV/ c . Cross sections for the (p, pt) reaction (reaction (e)) are very small but are consistent with a spectroscopic factor of unity for $t + {}^4\text{He}$ in ${}^7\text{Li}$ (1986WA11). For reaction (e) see also (1983GO06, 1985PA04, 1985PAZL). See also ${}^5\text{He}$ and (1984AJ01).

See also ${}^8\text{Be}$, (1983AN18, 1983GLZZ, 1986SH1P, 1987GAZM, 1987PA1G), (1983CH1B, 1987LE33), (1986HA1T; applications) and (1984GU14, 1985KA1D, 1985PA03, 1986IM1A, 1987IM1F, 1987IM04, 1987VD01; theor.).

19. ${}^7\text{Li}(d, d){}^7\text{Li}$

Angular distributions have been reported for $E_d = 1.0$ to 28 MeV [see (1974AJ01, 1979AJ01)] and at 50 MeV (1988KO1C; prelim.). See also ${}^9\text{Be}$ and (1987GOZF) for a breakup study.

20. (a) ${}^7\text{Li}({}^3\text{He}, {}^3\text{He}){}^7\text{Li}$

(b) ${}^7\text{Li}({}^3\text{He}, \text{pd}){}^7\text{Li}$ $Q_m = -5.49353$

Angular distributions have been reported at $E({}^3\text{He}) = 11$ MeV to 44.0 MeV and at $E({}^3\vec{\text{He}}) = 33.3$ MeV: see (1974AJ01, 1984AJ01). The missing mass spectrum in reaction (b) at $E({}^3\text{He}) = 120$ MeV indicate, in addition to the unresolved group to ${}^7\text{Li}^*(0, 0.48)$, a small peak at $E_x = 17.8 \pm 0.5$ MeV, possibly some structure between 30 and 40 MeV, a peak at 40.5 ± 0.5 MeV ($\Gamma \approx 2\text{--}3$ MeV) and possibly some structure at higher energies (1985FR01). For pion production see (1984BR22).

21. (a) ${}^7\text{Li}(\alpha, \alpha){}^7\text{Li}$

(b) ${}^7\text{Li}(\alpha, 2\alpha){}^3\text{H}$ $Q_m = -2.4678$

Angular distributions (reaction (a)) have been reported for $E_\alpha = 3.6$ to 29.4 MeV [see (1974AJ01, 1984AJ01)] and at $E_\alpha = 35.3$ MeV (1985DI08; α to ${}^7\text{Li}^*(0, 0.48, 4.63, 6.68, 7.46, 9.67)$; collective coupled channel analysis). See also (1987BU27).

Reaction (b) has been studied at $E_{\alpha} = 18$ to 64.3 MeV [see (1974AJ01, 1984AJ01)] and at 27.2 MeV (1985KO29). ${}^7\text{Li}^*(4.63)$ is strongly involved in the sequential decay, as are possibly ${}^7\text{Li}^*(6.68, 7.46)$. See also (1987DM1C, 1987VA29, 1988DM1A), (1988BO46) and (1986ZE01, 1987KO1L; theor.).

22. (a) ${}^7\text{Li}({}^6\text{Li}, {}^6\text{Li}){}^7\text{Li}$
 (b) ${}^7\text{Li}({}^7\text{Li}, {}^7\text{Li}){}^7\text{Li}$

For reaction (a) see ${}^6\text{Li}$. The elastic angular distribution (reaction (b)) has been studied for $E({}^7\text{Li}) = 4.0$ to 6.5 MeV [see (1974AJ01)] and 2.0 to 5.5 MeV (1983NO08).

23. ${}^7\text{Li}({}^9\text{Be}, {}^9\text{Be}){}^7\text{Li}$

Elastic angular distributions have been measured at $E({}^7\text{Li}) = 34$ MeV [see (1979AJ01)] and at 78 MeV (1986GLZV, 1986GLZU; also to ${}^7\text{Li}^*(4.63)$). For the interaction cross section at 790 MeV/A see (1985TA18).

24. (a) ${}^7\text{Li}({}^{10}\text{B}, {}^{10}\text{B}){}^7\text{Li}$
 (b) ${}^7\text{Li}({}^{11}\text{B}, {}^{11}\text{B}){}^7\text{Li}$

For reaction (a) see ${}^{10}\text{B}$. Angular distributions have been studied for reaction (b) to ${}^7\text{Li}^*(0, 0.48)$ and at $E({}^7\text{Li}) = 34$ MeV (1987CO02, 1987CO16). See also (1987HNZZ; theor.).

25. (a) ${}^7\text{Li}({}^{12}\text{C}, {}^{12}\text{C}){}^7\text{Li}$
 (b) ${}^7\text{Li}({}^{13}\text{C}, {}^{13}\text{C}){}^7\text{Li}$

Angular distributions (reaction (a)) involving ${}^7\text{Li}^*(0, 0.48)$ have been studied at $E({}^7\text{Li}) = 4.5$ to 89 MeV [see (1975AJ02, 1979AJ01, 1984AJ01)] and at $E({}^7\text{Li}) = 53.8$ MeV and $E({}^{12}\text{C}) = 92.3$ MeV (1984VI02, 1986CO02; also to ${}^7\text{Li}^*(4.63)$) and at $E({}^7\text{Li}) = 131.8$ MeV (1988KA09; ${}^7\text{Li}^*(0 + 0.48)$); and various states in ${}^{12}\text{C}$) as well as at $E({}^7\text{Li}) = 21.1$ MeV (1984MO06; elastic). See also (1986GLZU) and ${}^{12}\text{C}$ in (1985AJ01, 1990AJ01). Breakup studies involving ${}^7\text{Li}^*(4.63)$ are reported at $E({}^7\text{Li}) = 70$ MeV (1986DAZP, 1986YOZU; prelim.) and 132 MeV (1986SHZP; prelim.). The interaction cross section on carbon at 790 MeV/A has been measured by (1985TA18).

The elastic scattering in reaction (b) has been studied for $E({}^7\text{Li}) = 4.5$ to 34 MeV [see ${}^{13}\text{C}$ in (1986AJ01)] and recently by (1987CO02, 1987CO16; 34 MeV; also to ${}^7\text{Li}^*(0.48)$). See

also (1983STZS), (1983BI13, 1984HA53, 1986KA1C, 1986MO1E, 1987PA12) and (1980KH09, 1982GU21, 1983KH1A, 1984BE35, 1984GR05, 1984UH1A, 1985HE25, 1985KH08, 1985SA13, 1986KA1B, 1986SA15, 1986SAZL, 1986SA1D, 1986YO1A, 1987AR13, 1987KA1I, 1987SA1C, 1988OT01, 1988SA10; theor.).

26. (a) ${}^7\text{Li}({}^{14}\text{N}, {}^{14}\text{N}){}^7\text{Li}$
(b) ${}^7\text{Li}({}^{15}\text{N}, {}^{15}\text{N}){}^7\text{Li}$

Elastic angular distributions (reaction (a)) are reported at $E({}^7\text{Li}) = 36$ MeV [see (1981AJ01)] and $E({}^{14}\text{N}) = 150$ MeV (1986GO1H) while those for reaction (b) have been studied at $E({}^7\text{Li}) = 28.8$ MeV [see ${}^{15}\text{N}$ in (1986AJ01)].

27. ${}^7\text{Li}({}^{16}\text{O}, {}^{16}\text{O}){}^7\text{Li}$

The elastic scattering has been studied at $E({}^7\text{Li}) = 9.0$ to 20 and at 68 MeV [see ${}^{16}\text{O}$ in (1986AJ04)] as well as at $E({}^7\text{Li}) = 50$ MeV (1984CO20). For fusion cross section and breakup studies see (1984MA28, 1986MA19, 1986SC28, 1988MA07). See also (1982GU21, 1988PR02; theor.).

28. ${}^7\text{Li}({}^{20}\text{Ne}, {}^{20}\text{Ne}){}^7\text{Li}$

Angular distributions have been studied at $E({}^7\text{Li}) = 36, 68$ and 89 MeV: see ${}^{20}\text{Ne}$ in (1983AJ01).

29. (a) ${}^7\text{Li}({}^{24}\text{Mg}, {}^{24}\text{Mg}){}^7\text{Li}$
(b) ${}^7\text{Li}({}^{25}\text{Mg}, {}^{25}\text{Mg}){}^7\text{Li}$
(c) ${}^7\text{Li}({}^{26}\text{Mg}, {}^{26}\text{Mg}){}^7\text{Li}$
(d) ${}^7\text{Li}({}^{27}\text{Al}, {}^{27}\text{Al}){}^7\text{Li}$

The elastic scattering has been studied at $E({}^7\text{Li}) = 89$ MeV and at 27 MeV (reaction (b)): see (1984AJ01). A study of the breakup on ${}^{27}\text{Al}$ is reported by (1986NAZV) and the interaction cross section at 790 MeV/A has been measured by (1985TA18). See also (1988OT01, 1988SA10; theor.).

30. (a) ${}^7\text{Li}({}^{28}\text{Si}, {}^{28}\text{Si}){}^7\text{Li}$
 (b) ${}^7\text{Li}({}^{40}\text{Ca}, {}^{40}\text{Ca}){}^7\text{Li}$
 (c) ${}^7\text{Li}({}^{48}\text{Ca}, {}^{48}\text{Ca}){}^7\text{Li}$

Angular distributions involving ${}^7\text{Li}^*(0, 0.48)$ and various states of ${}^{28}\text{Si}$ and ${}^{40}\text{Ca}$ have been studied at $E({}^7\text{Li}) = 45$ MeV. The elastic scattering on ${}^{40}\text{Ca}$ and ${}^{48}\text{Ca}$ has been studied at $E({}^7\text{Li}) = 28, 34$ and 89 MeV [the latter also to ${}^7\text{Li}^*(0.48)$]: see (1984AJ01). Angular distributions (reaction (b)) involving ${}^7\text{Li}^*(0, 0.48)$ have also been reported at $E({}^7\text{Li}) = 34$ MeV (1985SA25). See also (1985GO11, 1986SA1D, 1987SA1C; theor.).

31. ${}^7\text{Be}(\epsilon){}^7\text{Li}$ $Q_m = 0.862$

The decay proceeds to the ground and 0.48 MeV states. The branching ratio to ${}^7\text{Li}^*(0.48)$ is $(10.52 \pm 0.06)\%$: see Table 7.6 and (1984AJ01). The adopted half-life is 53.29 ± 0.07 d. Both transitions are superallowed: $\log ft = 3.32$ and 3.55 for the decays to ${}^7\text{Li}^*(0, 0.48)$. See also (1979AJ01). The first-excited state has E_x [from E_γ] = 477.612 ± 0.002 keV: see (1984AJ01). See also (1983TAZY), (1982BA1J, 1983FO1A, 1983VO1C, 1984BO1C, 1984DA1H, 1984HA1M, 1984SU1A, 1985BA1N, 1985BA1M, 1985CA41, 1985DE1H, 1985KR1B, 1986GR04, 1986HA1I, 1986RO1N, 1987AR1J, 1987BA89, 1987FR1C, 1987KR10, 1987RI1E, 1987RO25, 1987WE1C, 1988BA86, 1988FO1A; astrophysics) and (1983WA13, 1983WA1J, 1986DU1E, 1986HA1Q, 1987DR1A; theor.).

32. ${}^9\text{Be}(\pi^-, 2n){}^7\text{Li}$ $Q_m = 119.866$

The capture of stopped pions has been studied in a kinematically complete experiment: ${}^7\text{Li}^*(0, 0.48)$ are weakly populated. Two large peaks are attributed to the excitation of ${}^7\text{Li}^*(7.46, 10.25)$. The recoil momentum distributions corresponding to these peaks are rather approxilar and both indicate a strong $L = 0$ component: see (1979AJ01).

33. ${}^9\text{Be}(n, t){}^7\text{Li}$ $Q_m = -10.4378$

An angular distribution is reported at $E_n = 14.6$ MeV (1987ZA01; t_{0+1}). See also (1979AJ01) and ${}^{10}\text{Be}$.

34. (a) ${}^9\text{Be}(p, {}^3\text{He}){}^7\text{Li}$ $Q_m = -11.2016$
 (b) ${}^9\text{Be}(p, \text{pd}){}^7\text{Li}$ $Q_m = -16.6951$

At $E_p = 43.7$ MeV angular distributions have been obtained for the ^3He particles corresponding to $^7\text{Li}^*(0, 0.48, 4.63, 7.46)$. The 7.46 MeV state is strongly excited while the mirror state in ^7Be is not appreciably populated in the mirror reaction (see reaction 17 in ^7Be). The angular distribution indicates that the transition to $^7\text{Li}^*(7.46)$ involves both $L = 0$ and 2, with a somewhat dominant $L = 0$ character. The $J^\pi = \frac{3}{2}^-, T = \frac{3}{2}$ state is located at $E_x = 11.28 \pm 0.04$ MeV, $\Gamma = 260 \pm 50$ keV: see (1979AJ01). Reaction (b) at $E_p = 58$ MeV involved $^7\text{Li}^*(0, 0.48, 7.47)$ (1985DE17). See also (1987KA25).

35. (a) $^9\text{Be}(d, \alpha)^7\text{Li}$ $Q_m = 7.1516$
 (b) $^9\text{Be}(d, t)2\ ^4\text{He}$ $Q_m = 4.6838$

Angular distributions have been measured for $E_d = 0.4$ to 27.5 MeV [see (1966LA04, 1974AJ01, 1979AJ01)] and at $E_d = 2.0$ to 2.8 MeV (1984AN16; α_0, α_1). A study at 11 MeV finds $\Gamma_{\text{c.m.}} = 93 \pm 25$ and 80 ± 20 keV, respectively for $^7\text{Li}^*(4.63, 7.46)$. No evidence is found for the $T = \frac{3}{2}$ state $^7\text{Li}^*(11.25)$. In a kinematically complete study of reaction (b) at $E_d = 26.3$ MeV, $^7\text{Li}^*(4.6, 6.5 + 7.5, 9.4)$ are strongly excited. No sharp α -decaying states of ^7Li are observed with $10 < E_x < 25$ MeV. Parameters for $^7\text{Li}^*(9.7)$ are $E_x = 9.36 \pm 0.05$ MeV, $\Gamma = 0.8 \pm 0.2$ MeV: see (1979AJ01). [$E_x = 6.75 \pm 0.20$ MeV, $\Gamma = 0.87 \pm 0.20$ MeV (1986PAZN; prelim.)]. A study of inclusive α -spectra at $E_d = 50$ MeV has been reported by (1987KA17) who suggest the involvement of a ^7Li state at $E_x = 18 \pm 1$ MeV, $\Gamma = 5 \pm 1$ MeV. For reaction (b) see also (1987VA29). See also ^{11}B in (1985AJ01) and (1988NE1A; theor.).

36. (a) $^9\text{Be}(^6\text{Li}, ^8\text{Be})^7\text{Li}$ $Q_m = 5.585$
 (b) $^9\text{Be}(^9\text{Be}, ^{11}\text{B})^7\text{Li}$ $Q_m = -0.8798$

Angular distributions involving $^7\text{Li}^*(0, 0.48)$ have been reported at $E(^6\text{Li}) = 32$ MeV (1985CO09) and $E(^9\text{Be}) = 14$ MeV (1985JA09).

37. $^{10}\text{B}(n, \alpha)^7\text{Li}$ $Q_m = 2.7905$

Angular distributions of α_0, α_1 and of α_2 at the higher energies have been measured at $E_n = 2$ keV to 14.4 MeV: see (1979AJ01, 1984AJ01). $\tau_m(0.48) = 102 \pm 5$ fsec (1985KO47). A search for an asymmetry of α -particles emitted forward and backward with respect to the neutron spin (due to parity non-conserving effects) gives upper limits of 3.7×10^{-6} and 6.1×10^{-7} for the α_0 and α_1 groups, respectively (1986ER05). For other polarization studies (involving both n and ^{10}B) see (1986KO19) and ^{11}B in (1990AJ01). See also (1986CO1M; applications).

Table 7.6: The branching ratio of ${}^7\text{Be}(\epsilon){}^7\text{Li}$ to ${}^7\text{Li}^*(0.48)$

Branching ratio (%)	Reference
10.32 ± 0.16	(1962TA11)
10.42 ± 0.18	(1973PO10)
10.35 ± 0.08	(1974GO26)
10.10 ± 0.45	(1983BA15)
10.61 ± 0.23	(1983DA14)
10.6 ± 0.5	(1983DO07)
10.61 ± 0.17	(1984FI10)
10.7 ± 0.2	(1983MA34)
9.8 ± 0.5	(1983NO03)
10.9 ± 1.1	(1983KN10)
11.4 ± 0.7	(1984EV01)
10.49 ± 0.07	(1984SK01)
10.52 ± 0.06	weighted mean ^a

^a Weighted mean of “modern” experiments. The weighted mean of all values shown above is $(10.45 \pm 0.04)\%$.

$$38. {}^{10}\text{B}(\text{d}, {}^5\text{Li}){}^7\text{Li} \quad Q_{\text{m}} = -1.40$$

See ${}^5\text{Li}$.

$$39. {}^{10}\text{B}(\alpha, {}^7\text{Be}){}^7\text{Li} \quad Q_{\text{m}} = -16.200$$

Angular distributions involving ${}^7\text{Li}_{\text{g.s.}}$ and ${}^7\text{Be}_{\text{g.s.}}$ and ${}^7\text{Li}^*(0.48) + {}^7\text{Be}^*(0.43)$ have been studied at $E_{\alpha} = 91.8$ MeV (1985JA12, 1986JA03). See also (1988SH1E; theor.).

$$40. {}^{11}\text{Be}(\beta^{-}){}^{11}\text{B}^* \rightarrow {}^7\text{Li} + \alpha \quad Q_{\text{m}} = 1.216$$

Delayed α -particles have been observed in the β^{-} decay of ${}^{11}\text{Be}$: they are due to the decay of ${}^{11}\text{B}^*(9.88)$ [$J^{\pi} = \frac{3}{2}^{+}$]. This state decays by α -emission ($87.4 \pm 1.2\%$) to the ground state of ${}^7\text{Li}$ and ($12.6 \pm 1.2\%$) to ${}^7\text{Li}^*(0.48)$ (1981AL03). See also ${}^{11}\text{Be}$, ${}^{11}\text{B}$ in (1985AJ01).

41. $^{11}\text{B}(^3\text{He}, ^7\text{Be})^7\text{Li}$ $Q_m = -7.076$

Angular distributions involving $^7\text{Li}_{g.s.}$ and $^7\text{Be}_{g.s.}$ and $^7\text{Li}^*(0.48) + ^7\text{Be}^*(0.43)$ have been studied at $E(^3\text{He}) = 71.8$ MeV (1986JA02, 1986JA03). See also (1987KW01, 1987KW03; theor.).

42. $^{11}\text{B}(\alpha, ^8\text{Be})^7\text{Li}$ $Q_m = -8.7556$

Angular distributions have been measured at $E_\alpha = 27.2$ to 29.0 MeV and at 65 MeV. At $E_\alpha = 65$ and 72.5 MeV, $^7\text{Li}^*(0, 4.63)$ are very strongly populated while $^7\text{Li}^*(0.48, 6.68, 7.46)$ are weakly excited: see (1979AJ01, 1984AJ01).

43. $^{12}\text{C}(d, ^7\text{Be})^7\text{Li}$ $Q_m = -17.540$

Angular distributions involving $^7\text{Li}_{g.s.}$ and $^7\text{Be}_{g.s.}$ and $^7\text{Li}^*(0.48) + ^7\text{Be}^*(0.43)$ have been studied at $E_d = 39.8$ MeV [see (1979AJ01)] and at 78.0 MeV (1986JA03, 1986JA15). See also (1984NE1A) and (1987KW01, 1987KW03; theor.).

44. $^{12}\text{C}(t, ^8\text{Be})^7\text{Li}$ $Q_m = -4.8988$

Angular distributions have been studied at $E_t = 38$ MeV to $^8\text{Be}_{g.s.}$ and $^7\text{Li}^*(0, 0.48)$ (1986SIZS; prelim.).

45. $^{12}\text{C}(\alpha, ^9\text{B})^7\text{Li}$ $Q_m = -24.898$

Angular distributions are reported at $E_\alpha = 49.0$ and 80.1 MeV (1984GO03). See also (1984AJ01).

46. $^{12}\text{C}(^6\text{Li}, ^{11}\text{C})^7\text{Li}$ $Q_m = -11.472$

Angular distributions have been obtained at $E(^6\text{Li}) = 36$ MeV for the transitions to $^7\text{Li}^*(0, 0.48)$: see (1979AJ01). See also (1986GL1E).

47. $^{13}\text{C}(d, ^8\text{Be})^7\text{Li}$ $Q_m = -3.5879$

At $E_d = 14.6$ MeV angular distributions are reported for the transitions to ${}^7\text{Li}^*(0, 0.48)$ and ${}^8\text{Be}_{\text{g.s.}}$: see (1979AJ01). See also (1984NE1A, 1984SH1D).

48. ${}^{14}\text{N}(n, 2\alpha){}^7\text{Li}$ $Q_m = -8.8220$

At $E_n = 14.1$ MeV, ${}^7\text{Li}^*(0, 0.48)$ are approximately equally populated: see (1979AJ01). Differential cross sections have been measured at $E_n = 14.4$ and 18.2 MeV involving ${}^8\text{Be}_{\text{g.s.}}$ and ${}^7\text{Li}^*(0 + 0.48, 4.63)$ (1986TU02).

49. (a) ${}^{17}\text{O}(d, {}^{12}\text{C}){}^7\text{Li}$ $Q_m = -2.5803$
(b) ${}^{18}\text{O}(d, {}^{13}\text{C}){}^7\text{Li}$ $Q_m = -5.678$
(c) ${}^{19}\text{F}(d, {}^{14}\text{N}){}^7\text{Li}$ $Q_m = -6.1220$

At $E_d = 14.6$ to 15.0 MeV, angular distributions have been measured for the transitions to ${}^{12}\text{C}(0) + {}^7\text{Li}^*(0, 0.48)$ [reaction (a)], ${}^{13}\text{C}(0) + {}^7\text{Li}^*(0, 0.48)$ [reaction (b)] and ${}^{14}\text{N}(0) + {}^7\text{Li}^*(0, 0.48)$ [reaction (c)]: see (1979AJ01). See also (1984AJ01).

⁷Be
(Figs. 2 and 3)

GENERAL: See also (1984AJ01).

Nuclear models: (1983BU1B, 1983FU1D, 1983HO22, 1983PA06, 1984BA53, 1984KA06, 1984WA02, 1985FI1E, 1986FI07, 1986KR12, 1986VA13).

Special states: (1982PO12, 1983BU1B, 1983HO22, 1984FI20, 1984WA02, 1985FI1E, 1986FI07, 1986VA13, 1986XU02, 1988KW02).

Electromagnetic transitions, giant resonances: (1984KA06, 1985FI1E, 1986FI07, 1986ME13).

Astrophysical questions: (1984EN1A, 1984HA1B, 1984RA1E, 1985BO1E, 1985GI1C, 1985DE1K, 1985KL1A, 1986BA50, 1986HU1D, 1986MA1U, 1986ME13, 1987FI1C, 1987KA1U, 1987MA1X, 1987MA2C, 1987RA1D, 1988KA07).

Complex reactions involving ⁷Be: (1981AS04, 1983AS05, 1983EN04, 1983GU1A, 1983MA53, 1983OL1A, 1983SO08, 1983ST1A, 1983WA19, 1984BE1E, 1984GL06, 1984GO03, 1984GR08, 1984HI1A, 1984MO29, 1984NE1A, 1984ST1B, 1985BA1L, 1985JA18, 1985MO08, 1985MO17, 1985MO24, 1985ST1B, 1985TA18, 1985TR1B, 1985WO11, 1986AV1B, 1986AV07, 1986BL12, 1986CA30, 1986CS1A, 1986GL1E, 1986GO1B, 1986ME06, 1986MO13, 1986WE1C, 1986XU02, 1986XU1B, 1987AU1C, 1987BA38, 1987BL13, 1987CH26, 1987DE37, 1987DU07, 1987FE1A, 1987GE1B, 1987GL05, 1987GR11, 1987HA45, 1987JA06, 1987KO15, 1987LY04, 1987NA01, 1987NI04, 1987PO23, 1987ST01, 1987TAZU, 1987TR05, 1987VI14, 1987WA09, 1987YA16, 1988BE09, 1988BL09, 1988BUZI, 1988BU1Q, 1988CA06, 1988CEZZ, 1988GO1F, 1988KI05, 1988KW02, 1988LI1A, 1988PO1F, 1988RU01, 1988SA19, 1988VA1E, 1988VUZZ).

Applications: (1983AS03, 1984EN1A, 1985TA1D, 1986FI1C, 1987FI1C, 1988IV1A).

Reactions involving pions and kaons: (1983KA19, 1984HU1C, 1985LA20, 1985MO1F, 1987KA09, 1988GIZU).

Hypernuclei: (1982KA1D, 1983SH38, 1983SH1E, 1984MI1C, 1984MI1E, 1984ZH1B, 1985AH1A, 1986DA1B, 1987MI38, 1987PO1H, 1988TA29).

Other topics: (1983FU1D, 1983PA06, 1985AN28, 1987AJ1A, 1988FIZT, 1988KW02).

Ground state of ⁷Be: (1983ANZQ, 1984KA06, 1985AN28, 1985FI1E, 1985HA18, 1985TA18, 1986KO1U, 1987KA1U, 1987KA22, 1988KA07).

The interaction nuclear radius of ⁷Be is 2.22 ± 0.02 fm (1985TA18). [See also for derived nuclear matter, charge and neutron matter r.m.s. radii].

1. ⁷Be(ϵ)⁷Li $Q_m = 0.862$

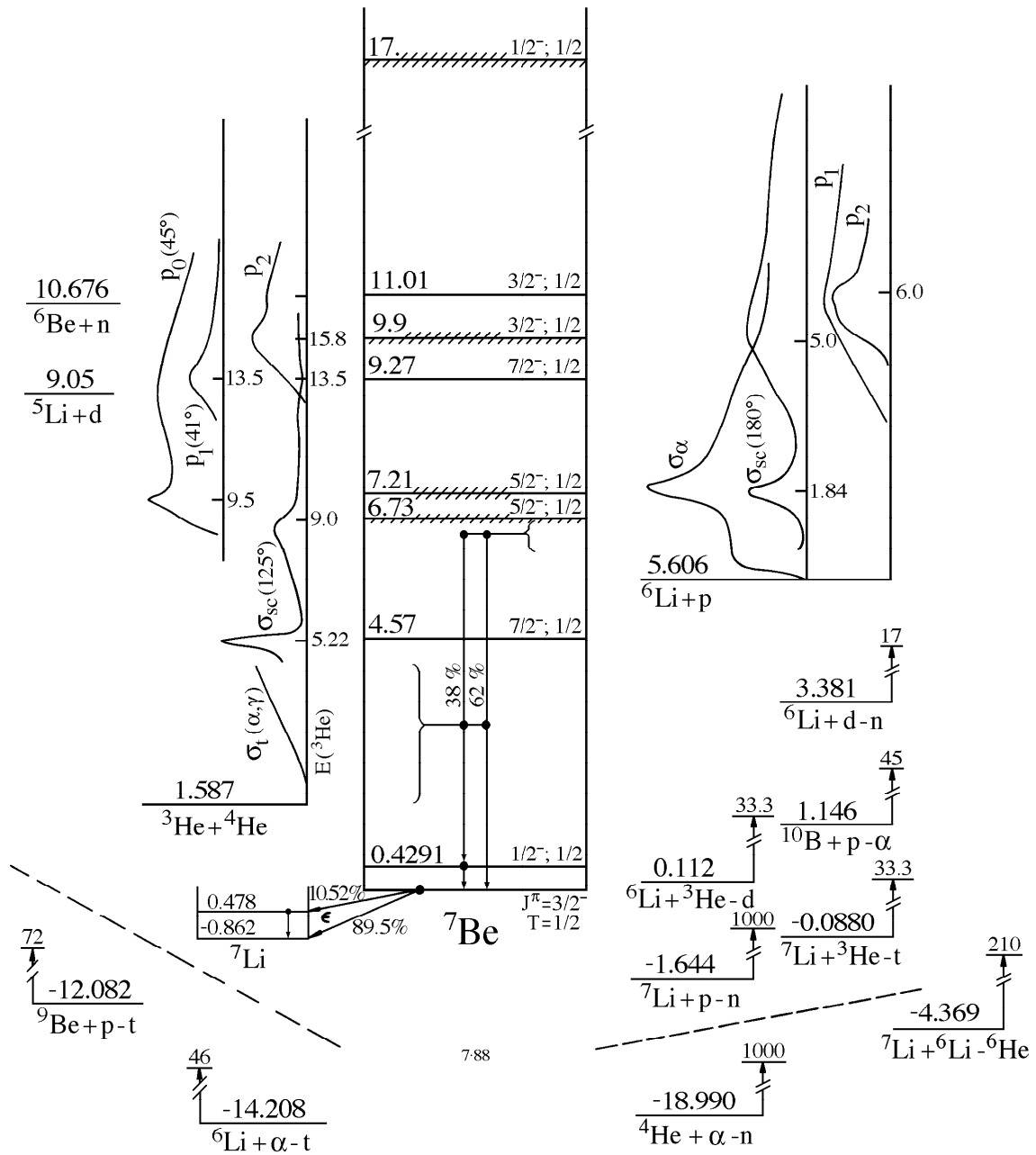

Fig. 2: Energy levels of ${}^7\text{Be}$. For notation see Fig. 1.

Table 7.7: Energy levels of ${}^7\text{Be}$

E_x (MeV \pm keV)	$J^\pi; T$	τ or $\Gamma_{\text{c.m.}}$	Decay	Reactions
g.s.	$\frac{3}{2}^-; \frac{1}{2}$	$\tau_{1/2} = 53.29 \pm 0.07$ d	ϵ	1, 2, 4, 5, 9, 10, 11, 12, 13, 14, 15, 16, 17, 18, 20, 21, 22, 23, 24, 25, 27, 28
0.42908 ± 0.10	$\frac{1}{2}^-; \frac{1}{2}$	$\tau_m = 192 \pm 25$ fsec	γ	2, 4, 5, 9, 10, 13, 15, 16, 17, 18, 19, 20, 21, 22, 23, 24, 25, 27, 28
4.57 ± 50	$\frac{7}{2}^-; \frac{1}{2}$	$\Gamma = 175 \pm 7$ keV	${}^3\text{He}, \alpha$	3, 5, 10, 13, 15, 16, 17, 18
6.73 ± 100	$\frac{5}{2}^-; \frac{1}{2}$	1.2 MeV	${}^3\text{He}, \alpha$	3, 8, 9, 13, 17
7.21 ± 60	$\frac{5}{2}^-; \frac{1}{2}$	≤ 0.5 MeV	p, ${}^3\text{He}, \alpha$	3, 6, 8, 9, 13, 16
9.27 ± 100	$\frac{7}{2}^-; \frac{1}{2}$		p, ${}^3\text{He}, \alpha$	3
9.9	$\frac{3}{2}^-; \frac{1}{2}$	≈ 1.8 MeV	p, ${}^3\text{He}, \alpha$	3, 6
11.01 ± 30	$\frac{3}{2}^-; \frac{3}{2}$	320 ± 30	p, ${}^3\text{He}, \alpha$	3, 6, 13, 17
17 ^a	$\frac{1}{2}^-; \frac{1}{2}$	≈ 6.5 MeV	${}^3\text{He}$	3

^a For possible states at higher E_x see reactions 3 and 6.

The decay is complex: see ${}^7\text{Li}$.

2. ${}^4\text{He}({}^3\text{He}, \gamma){}^7\text{Be}$

$$Q_m = 1.587$$

The capture cross sections have been measured for $E_\alpha = 0.250$ to 5.80 MeV and at $E({}^3\text{He}) = 19$ to 26 MeV [see (1974AJ01, 1984AJ01)], at $E_{\text{c.m.}} = 195$ to 686 keV (1988HI06), and at $E_\alpha = 385$ to 2728 keV (1984OS03) and 1225 keV (1984AL24). One of the main reasons for doing these measurements is to determine the astrophysical $S(0)$ factor. The values of $S(0)$ appear, on the average, to be higher if the experiment involves measurement of the 0.48 MeV γ following ϵ -capture rather than if it involves a direct measurement of the capture γ -rays. It is not entirely clear why this should be so. Contaminant production of ${}^7\text{Be}$ may be involved: see (1988HI06) and e.g. (1984AL24, 1985FI1D, 1986LA22). Earlier measurements, sometimes recalculated, are discussed by (1986LA22, 1987KA1R, 1988HI06). The latter adopt best values of $S(0) = 0.51 \pm 0.02$ keV \cdot b [prompt γ -rays] and 0.58 ± 0.02 keV \cdot b [${}^7\text{Be}$ activity] (1988HI06). See also (1984AL24, 1985FI1D, 1987KA1R, 1988BA86). Theoretical calculations are in general agreement with the experimental values. For instance (1985BU02) from a cluster-model calculation obtain $S(0) =$

0.47 ± 0.02 keV·b while (1983WA13, 1984WA06) obtain $S(0) = 0.60$ keV·b. The solar model calculations of (1982BA80) used $S_{34}[S(0)] = 0.52 \pm 0.02$ keV·b. It appears clear that the uncertainty in S_{34} is not of severe consequence to the solar neutrino problem [see, e.g. (1985FI1D)]. For astrophysical considerations see (1984AJ01) and (1982BA1J, 1982KA1E, 1983FO1A, 1983HA1B, 1984DA1H, 1984HA1M, 1984IW01, 1984WA11, 1984YA1A, 1985BA1Q, 1985BO1K, 1985CA4I, 1985DE1K, 1985KA1H, 1985KA1K, 1986BA50, 1986FI15, 1986KA45, 1986ME13, 1987AR1J, 1987AS05, 1987RO25, 1987WE1C, 1988FO1A, 1988KAZY, 1988KA07, 1988KA1H). See also (1986LI04; theor.).

3. (a) ${}^4\text{He}({}^3\text{He}, {}^3\text{He}){}^4\text{He}$

$$E_b = 1.587$$

(b) ${}^4\text{He}({}^3\text{He}, p){}^6\text{Li}$

$$Q_m = -4.0185$$

Elastic-scattering studies have been reported for $E = 0.25$ to 198.4 MeV [see (1974AJ01, 1979AJ01, 1984AJ01)] and at $E_\alpha = 56.3$ to 95.5 MeV (1985NE08, 1986YA14). Polarization measurements have been carried out at $E = 4.3$ to 98 MeV [see (1979AJ01)] and at $E({}^3\vec{H}e) = 55$ to 95 MeV (1986YA14).

For $l \leq 4$, only f-wave phase shifts show resonance structure for $E({}^3\text{He}) < 18$ MeV, corresponding to ${}^7\text{Be}^*(4.57, 6.73, 9.27)$: see Table 7.7. No structure corresponding to ${}^7\text{Be}^*(7.21)$ ($J^\pi = \frac{5}{2}^-$) is seen in the elastic data. The s-wave phase shift is somewhat greater than hard-sphere. The decay of ${}^7\text{Be}^*(9.27)$ ($J^\pi = \frac{7}{2}^-$) to ${}^6\text{Li}(0)$ requires f-shell configuration admixture. An estimate of the yield of ground-state protons relative to those corresponding to ${}^6\text{Li}^*(2.19)$ yields $\gamma^2(p_0)/\gamma^2(p_1) = (16_{-10}^{+5})\%$. A phase-shift analysis (single-level R -matrix) has been carried out for $E({}^3\text{He}) = 18$ to 32 MeV: the p-wave phase shifts indicate a $\frac{1}{2}^-$ state at $E_x \approx 16.7$ MeV ($E_r = 26.4$ MeV), with $\Gamma = 6.5$ MeV. There is the suggestion also of broad $l = 4$ and 5 states at $E({}^3\text{He}) > 30$ MeV [$E_x > 19$ MeV]: see (1984AJ01).

The differential cross section for reaction (b) has been determined for $E({}^3\text{He}) = 8$ to 28 MeV [see (1979AJ01)] and at $E_\alpha = 22.2$ to 26.5 MeV. Resonances are observed corresponding to ${}^7\text{Be}^*(7.21, 9.27)$ in the p_0 yield, to ${}^7\text{Be}^*(9.27)$ in the p_1 yield and to states at $E_x \approx 10$ MeV ($T = \frac{1}{2}$) and 11.0 MeV ($T = \frac{3}{2}$) in the yield of 3.56 MeV γ -rays. The evidence for the latter derives mainly from interference arguments. There is also some evidence for an extremely broad $J^\pi = \frac{1}{2}^-$ structure at $E_x \geq 10$ MeV [see also ${}^6\text{Li}(p, p)$]: see Table 7.8 and (1974AJ01, 1984AJ01). For $\alpha + {}^3\text{He}$ correlations see (1987PO03). See also the ‘‘Complex Reactions’’ section. For elastic and inelastic inclusive scattering cross sections at $p_\alpha = 7.0$ GeV/ c see (1984SA39, 1987BA13). See also (1984IW01; astrophysics) and (1981PL1A, 1983HO22, 1983LO09, 1984BL21, 1984FI20, 1984HO1C, 1984HU1C, 1984KA01, 1985FR1F, 1986FR12, 1987KA09, 1987OSZZ, 1987TA06, 1988FIZT; theor.).

4. ${}^4\text{He}(\alpha, n){}^7\text{Be}$

$$Q_m = -18.990$$

Table 7.8: ${}^7\text{Be}$ levels from ${}^3\text{He} + {}^4\text{He}$ ^a

E_x (MeV \pm keV)	J^π	l_α	LS term	θ_α^2 ^b	θ_p^2
4.57 ± 50	$\frac{7}{2}^-$	3	${}^2\text{F}_{7/2}$	0.70 ± 0.04	
6.73 ± 100	$\frac{5}{2}^-$	3	${}^2\text{F}_{5/2}$	1.36 ± 0.13	0.000 ± 0.002
7.21 ± 60	$\frac{5}{2}^-$	3	${}^4\text{P}_{5/2}$	0.010 ± 0.001	0.26 ± 0.02
9.27 ± 100	$\frac{7}{2}^-$	3	${}^4\text{D}_{7/2}$	0.70 ± 0.26	$0.29_{-0.18}^{+0.09}$ ^f
10.0 ^c	$\frac{3}{2}^-$	1	$({}^4\text{P}_{3/2})$		
≈ 10.0 ^d	$\frac{1}{2}^-$		$({}^4\text{P}_{1/2})$		
11.00 ± 50 ^e	$\frac{3}{2}^-$	1	$({}^2\text{P}_{3/2}, {}^2\text{D}_{3/2})$		0.13 ± 0.02 ^g

^a See also Table 7.10 (1966LA04). For references see Table 7.7 in (1979AJ01).

^b $\gamma^2 / (\frac{3}{2}\hbar^2 / \mu a^2)$. $R = 4.0$ fm.

^c $\theta_{p1}^2 = 1.8 \pm 0.5$.

^d $\Gamma = 1.8$ MeV.

^e Broad.

^f $\Gamma = 0.4 \pm 0.05$ MeV; $T = \frac{3}{2}$.

^g θ_{p2}^2 .

Angular distributions have been reported at $E_\alpha = 61.5$ to 158.2 MeV (1982GL01) and 198.4 MeV (1985WO11) for the transitions to ${}^7\text{Be}^*(0 + 0.43)$. See also ${}^8\text{Be}$.

5. ${}^6\text{Li}(p, \gamma){}^7\text{Be}$ $Q_m = 5.606$

At low energies ($E_p = 0.2$ to 1.2 MeV) gamma transitions are observed to the ground (γ_0) and to the 0.43 MeV (γ_1) states. The yield shows no resonance and the branching ratio remains approximately constant at $(61 \pm 5)\%$ to the ground state and $(39 \pm 2)\%$ to ${}^7\text{Be}^*(0.43)$: see (1974AJ01, 1984AJ01). Angular distributions of γ_0 and γ_1 have been studied at $E_p = 0.50$, 0.80 and 1.00 MeV (1987TI05). At $E_p = 44.4$ MeV, ${}^7\text{Li}^*(4.57)$ is strongly populated (1985HA05). See also (1983OS04), (1983HA1B, 1984BO1C, 1985CA41; astrophysics) and (1985BL1B).

6. (a) ${}^6\text{Li}(p, p){}^6\text{Li}$ $E_b = 5.606$

(b) ${}^6\text{Li}(p, 2p){}^5\text{He}$ $Q_m = -4.59$

(c) ${}^6\text{Li}(p, p\alpha){}^2\text{H}$ $Q_m = -1.4750$

Measurements of elastic angular distributions have been reported for $E_p = 0.5$ to 600 MeV: see (1966LA04, 1974AJ01) and ${}^6\text{Li}$. Two resonances are reported at $E_p = 1.84$ and 5 MeV in

the elastic yield [${}^7\text{Be}^*(7.21, 9.9)$]. The parameters of the lower resonance are shown in Table 7.4. The 5 MeV resonance has $\Gamma \approx 1.8$ MeV and appears to also be formed by p-waves: γ_p^2 is then 3 ± 2 MeV \cdot fm. A weak rise near $E_p = 8$ to 9 MeV may indicate a further level, ${}^7\text{Be}^* \approx 13$ MeV. A broad resonance at $E_p = 14$ MeV has also been suggested. Polarization measurements have been carried out for $E_p = 1.2$ to 800 MeV [see (1974AJ01, 1979AJ01, 1984AJ01)] and at $E_{\bar{p}} = 4$ to 10 MeV (1986BE1H; p_0) and 25 and 35 MeV (1982ROZT, 1983PO1B, 1983POZX; p_0, p_1). A phase-shift analysis for $E_p = 0.5$ to 5.6 MeV shows that only ${}^2\text{S}$, ${}^4\text{S}$ and ${}^4\text{P}$ are involved. The ${}^4\text{P}_{5/2}$ phase resonates at $E_p = 1.8$ MeV, and the broad resonance at 5 MeV can be reproduced equally well by either ${}^4\text{P}_{3/2}$ or ${}^4\text{P}_{1/2}$: tensor polarization measurements are necessary to distinguish between the two: see (1974AJ01).

The reaction cross section for formation of ${}^6\text{Li}^*(2.19)$ has been measured for $E_p = 3.6$ to 9.40 MeV: a broad resonance indicates the presence of a state with $E_x \approx 10$ MeV, $\Gamma = 1.8$ MeV, $J^\pi = (\frac{3}{2}, \frac{5}{2})^-$, $T = \frac{1}{2}$. The cross-section and angular distributions of p_2 (${}^6\text{Li}^*(3.56)$) for $E_p = 4.26$ to 9.40 MeV are analyzed in terms of two $J^\pi = \frac{3}{2}^-$ states at $E_x \approx 10$ and 11 MeV: see reaction 3. The total cross section for formation of ${}^6\text{Li}^*(3.56)$ decreases slowly with energy for $E_p = 24.3$ to 46.4 MeV. The total reaction cross section has been measured for $E_p = 25.0$ to 48 MeV (1985CA36). K_y^y spectra at $E_{\bar{p}} = 50, 65$ and 80 MeV, $\theta = 3^\circ$ – 20° , are reported by (1987SA46).

For the inclusive cross section at $E_p = 200$ MeV [back angles] see (1984AV07). For reaction (b) see ${}^5\text{He}$. For reaction (c) see ${}^6\text{Li}$. See also ${}^7\text{Be}$, (1983GLZZ, 1984BA1U, 1987TO06), (1986PO1F, 1986SA1Q; applications), (1986BA88, 1986PF1A) and (1981NE1B, 1981PL1A, 1983HO22, 1983KA37, 1986SA30, 1987KN04; theor.).

$$7. {}^6\text{Li}(p, n){}^6\text{Be} \qquad Q_m = -5.071 \qquad E_b = 5.606$$

The yield of neutrons increases approximately monotonically from threshold to $E_p = 14.3$ MeV: see (1974AJ01). The transverse polarization transfer, $D_{NN}(0^\circ)$, for the g.s. transition has been measured for $E_{\bar{p}} = 30$ to 160 MeV: see (1986TA1E, 1984TA07) and ${}^6\text{Be}$. Polarization measurements are reported at $E_{\bar{p}} = 50$ and 80 MeV (1987SA46) and at 52.8 MeV (1988HE08) [$K_y^{y'}$ (0°) = -0.33 ± 0.04 ; also $K_z^{z'}$]. See also (1986MC09; $E_{\bar{p}} = 800$ MeV), ${}^6\text{Be}$, (1984BA1U, 1986SA1Q) and (1986RA21).

$$8. {}^6\text{Li}(p, \alpha){}^3\text{He} \qquad Q_m = 4.0185 \qquad E_b = 5.606$$

Thermonuclear reaction rates and the astrophysical S -factor have been derived from the low-energy ($E_p < 0.7$ MeV) cross section measurements: $S(0) \approx 3.1$ MeV \cdot b: see (1974AJ01, 1979AJ01, 1984AJ01). At higher energies the cross section exhibits a broad, low maximum near $E_p = 1$ MeV and a pronounced resonance at $E_p = 1.85$ MeV ($\Gamma < 0.5$ MeV). No other structure is reported up to $E_p = 5.6$ MeV. Measurements between $E_p = 0.4$ and 3.4 MeV show that the polarizations are generally large and positive: see (1974AJ01).

Angular distributions have been reported for $E_p = 0.15$ to 45 MeV [see (1974AJ01, 1979AJ01, 1984AJ01)] and at 47.8, 53.5, 58.5 and 62.5 MeV (1984NE05). See also (1983SZZY, 1986KIIG), (1985CA41; astrophys.), (1986MC1D; applications) and (1984KR1B; theor.).

9. ${}^6\text{Li}(d, n){}^7\text{Be}$ $Q_m = 3.381$

Angular distributions of the n_0 and n_1 groups have been measured at $E_d = 0.20$ to 15.25 MeV: see (1974AJ01, 1979AJ01). The $n_1-\gamma$ correlations are isotropic, indicating $J^{\pi_i} = \frac{1}{2}^-$ for ${}^7\text{Be}^*$ (0.43). Broad maxima are observed in the ratio of low-energy to high-energy neutrons at $E_d = 4.2$ and 5.1 MeV [${}^7\text{Be}^*(6.5, 7.2)$, $\Gamma_{c.m.} = 1.2$ and 0.5 MeV, respectively]: see (1966LA04). See also ${}^8\text{Be}$ and (1988KO1C).

10. ${}^6\text{Li}({}^3\text{He}, d){}^7\text{Be}$ $Q_m = 0.112$

Angular distributions of the d_0 and d_1 groups to ${}^7\text{Be}^*(0, 0.43)$ have been measured at $E({}^3\text{He}) = 8, 10, 14$ and 18 MeV and at $E({}^3\vec{\text{He}}) = 33.3$ MeV [${}^7\text{Be}^*(4.57)$ is also populated]: see (1974AJ01, 1984AJ01).

11. ${}^6\text{Li}({}^6\text{Li}, {}^5\text{He}){}^7\text{Be}$ $Q_m = 1.01$

See (1987MI34) and ${}^5\text{He}$.

12. ${}^7\text{Li}(\pi^+, \pi^0){}^7\text{Be}$ $Q_m = 3.742$

Forward-angle differential cross sections have been measured at $E_{\pi^+} = 20$ MeV (1987IR01; also at 155° and 166°), at 33.5, 41.1, 48.7 and 58.8 MeV (1985IR01, 1985IR02), 70 to 180 MeV [see (1984AJ01)] and from 300 to 550 MeV (1988RO03).

13. ${}^7\text{Li}(p, n){}^7\text{Be}$ $Q_m = -1.644$

$$E_{\text{thresh.}} = 1880.443 \pm 0.020 \text{ keV (1985WH1A)}$$

The excitation energy of ${}^7\text{Be}^*(0.43)$ is 429.20 ± 0.10 keV, $\tau_m = 192 \pm 25$ fsec: see (1979AJ01). Angular distributions of n_0 and n_1 have been reported at $E_p = 1.9$ to 119.8 MeV [see (1974AJ01, 1979AJ01, 1984AJ01)] and at 200, 300 and 400 MeV (1987WAZT; prelim.; n_{0+1}). ${}^7\text{Be}^*(4.55, 6.51, 7.19, 10.79)$ have also been populated: see (1974AJ01, 1979AJ01). The ratios of σ_1/σ_0 (${}^7\text{Be}^*(0.43)/{}^7\text{Be}_{g.s.}$) have been measured at 24.8, 35 and 45 MeV and yield the ratio of spin-flip to spin-nonflip strength $|V_{0\tau}/V_\tau|^2$ (1980AU02). See also ${}^8\text{Be}$, (1983KI1B, 1984BR32, 1984JEZZ, 1984TA07, 1985JE1A, 1985TAZY, 1987HE24, 1988HE08), (1984KE1B, 1985BA66, 1985KE1D, 1986CO1L; applications), (1983RA1C, 1984TAZS, 1985GO1F, 1987GO1V, 1987RA32) and (1983KR10, 1984PE12; theor.).

14. (a) ${}^7\text{Li}(d, 2n){}^7\text{Be}$ $Q_m = -3.869$
 (b) ${}^7\text{Li}(t, 3n){}^7\text{Be}$ $Q_m = -10.126$

See (1987AL10; $E({}^7\text{Li}) = 65$ MeV).

15. ${}^7\text{Li}({}^3\text{He}, t){}^7\text{Be}$ $Q_m = -0.880$

Angular distributions of t_0 and t_1 have been measured at $E({}^3\text{He}) = 3.0$ to 4.0 MeV and at $E({}^3\text{He}) = 33.3$ MeV: see (1974AJ01, 1984AJ01). The width of ${}^7\text{Be}^*(4.57)$, $\Gamma_{c.m.} = 175 \pm 7$ keV: see (1974AJ01). See also ${}^{10}\text{B}$.

16. ${}^7\text{Li}({}^6\text{Li}, {}^6\text{He}){}^7\text{Be}$ $Q_m = -4.369$

This reaction has been studied at $E({}^6\text{Li}) = 14, 25$ and 35 MeV/A. ${}^7\text{Be}^*(0, 0.43)$ are strongly populated and ${}^7\text{Be}^*(4.57, 7.21)$ are also evident. At the highest energy the reaction mechanism is predominantly one-step (1987WI09, 1986AN29). See also ${}^6\text{He}$, (1988AL1G, 1988BUZH, 1988BU1Q), (1986AU1C, 1987AU04, 1988AN1J) and (1984BA53; theor.).

17. ${}^9\text{Be}(p, t){}^7\text{Be}$ $Q_m = -12.082$

Angular distributions of tritons have been measured at $E_p = 43.7$ and 46 MeV [see (1979AJ01)] and at 50 and 72 MeV (1984ZA07; t_{0+1}, t_2). The 11 MeV state has $E_x = 11.01 \pm 0.04$ MeV, $\Gamma = 298 \pm 25$ keV, $J^\pi = \frac{3}{2}^-$, $T = \frac{3}{2}$ [the J^π ; T assignments are based on the similarity of the angular distribution to that in the $(p, {}^3\text{He})$ reaction to ${}^7\text{Li}^*(11.13)$]: see (1979AJ01).

18. $^{10}\text{B}(\text{p}, \alpha)^7\text{Be}$ $Q_m = 1.146$

Angular distributions have been studied for $E_p = 2.8$ to 7.0 MeV [see (1974AJ01)] and for 18 to 45 MeV (1986HA27; $\alpha_0, \alpha_1, \alpha_2$; see for spectroscopic factors). E_x of $^7\text{Be}^*(0.43) = 428.89 \pm 0.13$ keV (1979RI12). See also ^{11}C in (1985AJ01), (1983DO07) and (1988KOZL; applied).

19. $^{10}\text{B}(\text{d}, ^5\text{He})^7\text{Be}$ $Q_m = -1.97$

See ^5He .

20. $^{10}\text{B}(\alpha, ^7\text{Li})^7\text{Be}$ $Q_m = -16.200$

See ^7Li .

21. $^{11}\text{B}(^3\text{He}, ^7\text{Li})^7\text{Be}$ $Q_m = -7.076$

See ^7Li .

22. $^{12}\text{C}(\text{p}, ^6\text{Li})^7\text{Be}$ $Q_m = -22.566$

See ^6Li and (1987KW03; theor.).

23. $^{12}\text{C}(\text{d}, ^7\text{Li})^7\text{Be}$ $Q_m = -17.540$

See ^7Li .

24. $^{12}\text{C}(^3\text{He}, ^8\text{Be})^7\text{Be}$ $Q_m = -5.779$

Angular distributions involving $^7\text{Be}^*(0, 0.43)$ have been reported at $E(^3\text{He}) = 25.5$ to 70 MeV [see (1979AJ01, 1984AJ01)] and at $E(^3\text{He}) = 33.4$ MeV (1986CL1B; also A_y ; prelim.). See also (1986RA15; theor.).

25. $^{12}\text{C}(\alpha, ^9\text{Be})^7\text{Be}$ $Q_m = -24.692$

At $E_\alpha = 42$ MeV, angular distributions have been measured involving $^7\text{Be}^*(0, 0.43)$ and $^9\text{Be}_{\text{g.s.}}$: see (1974AJ01). Angular distributions have also been measured at $E_\alpha = 49.0$ and 80.1 MeV (1984GO03).

26. $^{12}\text{C}(^7\text{Li}, ^{12}\text{B})^7\text{Be}$ $Q_m = -14.231$

See (1984BA53; theor.).

27. $^{16}\text{O}(^3\text{He}, ^{12}\text{C})^7\text{Be}$ $Q_m = -5.5746$

Angular distributions have been reported at $E(^3\text{He}) = 25.5$ to 70 MeV to $^7\text{Be}^*(0, 0.43)$ and to various states of ^{12}C : see ^{12}C in (1985AJ01). See also (1986BA89; theor.).

28. $^{16}\text{O}(^7\text{Li}, ^{16}\text{N})^7\text{Be}$ $Q_m = -11.281$

Angular distributions have been studied at $E(^7\text{Li}) = 50$ MeV involving $^7\text{Be}^*(0, 0.43)$ and various states of ^{16}N (1984CO20, 1986CL03). See also ^{16}N in (1986AJ04) and (1984BA53; theor.).

29. $^{24}\text{Mg}(^3\text{He}, ^{20}\text{Ne})^7\text{Be}$ $Q_m = -7.723$

See (1986RA15; theor.).

^7B (Fig. 3)

The mass excess of ^7B from a study of the $^{10}\text{B}(^3\text{He}, ^6\text{He})^7\text{B}$ reaction is 27.94 ± 0.10 MeV and the width of the ground state is $\Gamma = 1.4 \pm 0.2$ MeV: see (1974AJ01). ^7B is unbound with respect to $^6\text{Be} + \text{p}$, $^5\text{Li} + 2\text{p}$ and $^4\text{He} + 3\text{p}$ by 2.28 , 1.68 and 3.65 MeV, respectively. The other work described in (1984AJ01) has not been published. See also (1985AN28), (1986HU1D; astrophysics) and (1982KA1D, 1983ANZQ, 1983AU1B; theor.).

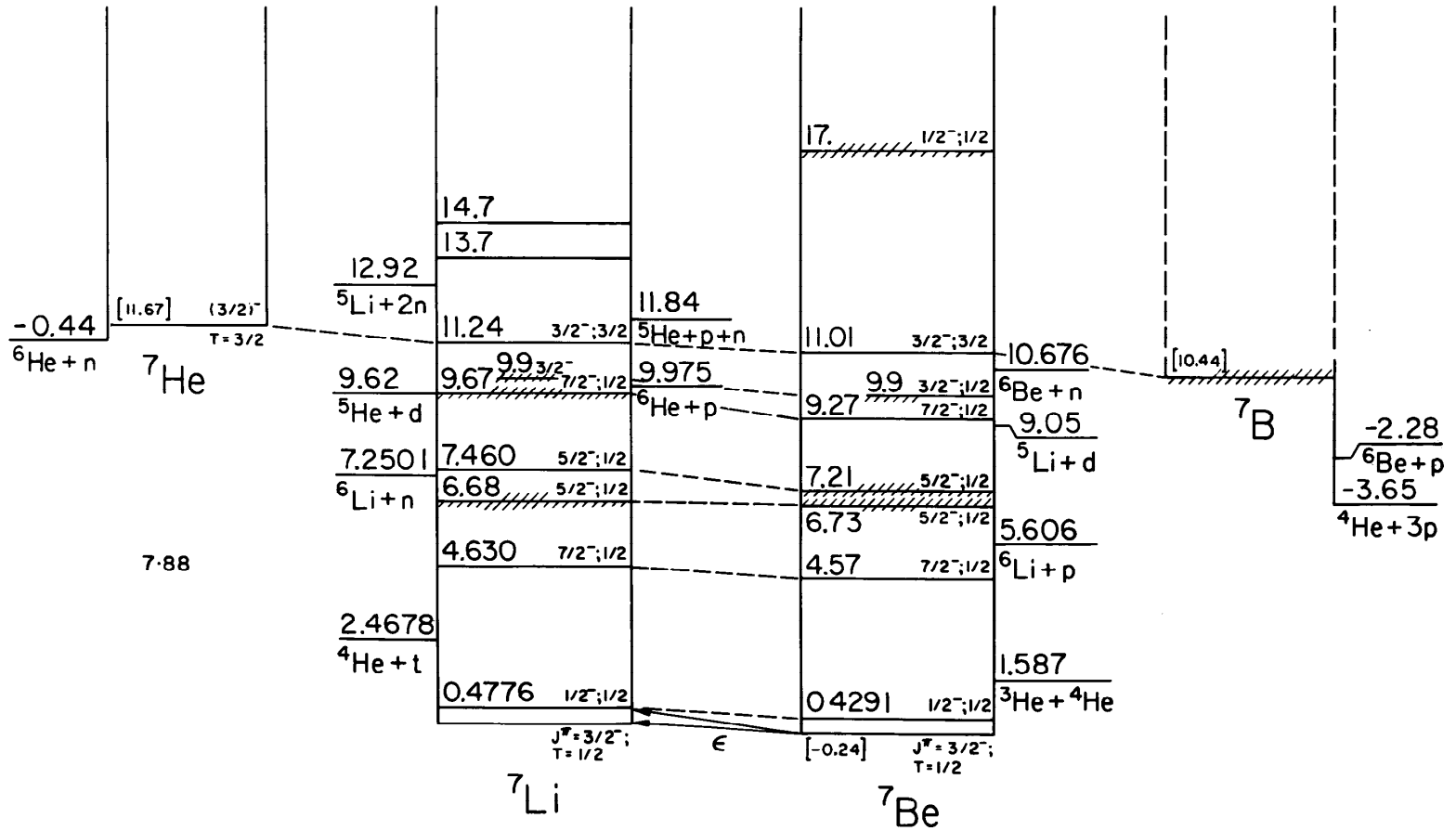

Fig. 3: Isobar diagram, $A = 7$. The diagrams for individual isobars have been shifted vertically to eliminate the neutron-proton mass difference and the Coulomb energy, taken as $E_C = 0.60Z(Z-1)/A^{1/3}$. Energies in square brackets represent the (approximate) nuclear energy, $E_N = M(Z, A) - ZM(\text{H}) - NM(\text{n}) - E_C$, minus the corresponding quantity for ${}^7\text{Li}$: here M represents the atomic mass excess in MeV. Levels which are presumed to be isospin multiplets are connected by dashed lines.

References

(Closed 1 June 1988)

References are arranged and designated by the year of publication followed by the first two letters of the first-mentioned author's name and then by two additional characters. Most of the references appear in the National Nuclear Data Center files (Nuclear Science References Database) and have NNDC key numbers. Otherwise, TUNL key numbers were assigned with the last two characters of the form 1A, 1B, etc. In response to many requests for more informative citations, we have, when possible, included up to ten authors per paper and added the authors' initials.

- 1952AJ38 F. Ajzenberg and T. Lauritsen, *Rev. Mod. Phys.* 24 (1952) 321
- 1962TA11 J.G.V. Taylor and J.S. Merritt, *Can. J. Phys.* 40 (1962) 926
- 1966LA04 T. Lauritsen and F. Ajzenberg-Selove, *Nucl. Phys.* 78 (1966) 1
- 1973PO10 W.P. Poenitz and A. Devolpi, *Int. J. Appl. Radiat. Isotop.* 24 (1973) 471
- 1974AJ01 F. Ajzenberg-Selove and T. Lauritsen, *Nucl. Phys.* A227 (1974) 1
- 1974GO26 I.W. Goodier, J.L. Makepeace and A. Williams, *Int. J. Appl. Radiat. Isotop.* 25 (1974) 373
- 1975AJ02 F. Ajzenberg-Selove, *Nucl. Phys.* A248 (1975) 1
- 1976GAYV D.I. Garber and R.R. Kinsey, *BNL 325, Vol. 2* (1976)
- 1978LEZA C.M. Lederer, V.S. Shirley, E. Browne, J.M. Dairiki, R.E. Doebler, A.A. Shihab-Eldin, L.J. Jardine, J.K. Tuli and A.B. Buyrn, *Table of Isotopes 7th Ed.* (1978)
- 1979AJ01 F. Ajzenberg-Selove, *Nucl. Phys.* A320 (1979) 1
- 1979GL12 H. Glattli, G.L. Bacchella, M. Fourmond, A. Malinovski, P. Meriel, M. Pinot, P. Roubeau and A. Abragam, *J. Phys.* 40 (1979) 629
- 1979RI12 Y. Rihet, G. Costa, C. Gerardin and R. Seltz, *Phys. Rev.* C20 (1979) 1583
- 1980AU02 S.M. Austin, L.E. Young, R.R. Doering, R. DeVito, R.K. Bhowmik and S.D. Schery, *Phys. Rev. Lett.* 44 (1980) 972; *Erratum Phys. Rev. Lett.* 44 (1980) 1711
- 1980BA34 F.C. Barker, *Aust. J. Phys.* 33 (1980) 159
- 1980KH09 S.A.E. Khallaf, *Rev. Roum. Phys.* 25 (1980) 741
- 1981AJ01 F. Ajzenberg-Selove, *Nucl. Phys.* A360 (1981) 1
- 1981AL03 D.E. Alburger, D.J. Millener and D.H. Wilkinson, *Phys. Rev.* C23 (1981) 473
- 1981AS04 E. Aslanides, P. Fassnacht, G. Dellacasa, M. Gallio and J.W.N. Tuyn, *Phys. Rev.* C23 (1981) 1826
- 1981MUZQ S.F. Mughabghab, M. Divadeenam and N.E. Holden, *Neutron Cross Sections Part A, Z=1-60* (1981)
- 1981NE1B O.F. Nemets and A.M. Vasnogordsky, *Fiz. Elem. Chastits At. Yadra* 12 (1981) 424

- 1981PL1A G.R. Plattner, *Nukleonika* 26 (1981)1005
- 1982AL33 D.V. Aleksandrov, Yu.A. Glukhov, A.S. Demyanova, V.I. Dukhanov, I.B. Mazurov, B.G. Novatsky, A.A. Ogloblin, S.B. Sakuta and D.N. Stepanov, *Yad. Fiz.* 36 (1982) 1351; *Sov. J. Nucl. Phys.* 36 (1982) 783
- 1982AL35 V.P. Alfimenkov, S.B. Borzakov, Vo Van Tkhuon, L.B. Pikelner and E.I. Sharapov, *Yad. Fiz.* 36 (1982) 1089; *Sov. J. Nucl. Phys.* 36 (1982) 637
- 1982AU1A Audouze and Reeves, *Essays in Nucl. Astrophys.* (1982) 355
- 1982BA1J Bahcall and Davis, *Essays in Nucl. Astrophys.* (1982) 243
- 1982BA60 Yu.A. Batusov, V.M. Sidorov, Ts.P. Spasov, D. Tuvdendorzh, Kh.M. Chernev and R.A. Eramzhyan, *Yad. Fiz.* 36 (1982) 578; *Sov. J. Nucl. Phys.* 36 (1982) 336
- 1982BA80 J.N. Bahcall, W.F. Huebner, S.H. Lubow, P.D. Parker and R.K. Ulrich, *Rev. Mod. Phys.* 54 (1982) 767
- 1982CA1A Cameron, *Essays in Nucl. Astrophys.* (1982) 23
- 1982GL01 B.G. Glagola, V.E. Viola, Jr., H. Breuer, N.S. Chant, A. Nadasen, P.G. Roos, S.M. Austin and G.J. Mathews, *Phys. Rev. C* 25 (1982) 34
- 1982GR1A Greenstein, *Essays in Nucl. Astrophys.* (1982) 45
- 1982GU21 I.S. Gurbanovich and N.S. Zelenskaya, *Yad. Fiz.* 36 (1982) 1180; *Sov. J. Nucl. Phys.* 36 (1982) 688
- 1982KA1D K. Kar and J.C. Parikh, *Pramana* 19 (1982) 555
- 1982KA1E Kavanagh, *Essays in Nucl. Astrophys.* (1982) 159
- 1982MO1B Motoba, *Proc. Workshop on Hypernucl. Phys., Japan* (1982) 36
- 1982PO12 V.S. Popov, A.E. Kudryavtsev, V.I. Lisin and V.D. Mur, *Pisma Zh. Eksp. Teor. Fiz.* 36 (1982) 207; *JETP Lett. (USSR)* 36 (1982) 257
- 1982ROZT D. Rowley, F.S. Dietrich, C.H. Poppe, H.E. Conzett, D. Eversheim and C. Rioux, *Bull. Amer. Phys. Soc.* 27 (1982) 700, AE5
- 1982SM02 A.B. Smith, P.T. Guenther and J.F. Whalen, *Nucl. Phys.* A373 (1982) 305
- 1982WA1B Wagoner, *Essays in Nucl. Astrophys.* (1982) 495
- 1983AB1B Abramov et al., *Sov. J. Nucl. Phys.* 38 (1983) 491
- 1983AJ01 F. Ajzenberg-Selove, *Nucl. Phys.* A392 (1983) 1; *Erratum Nucl. Phys.* A413 (1984) 168
- 1983AL1E Alfimenikov et al., in *Antwerp* (1983) 353
- 1983AM1A G. Amsel and J.A. Davies, *Nucl. Instrum. Meth. Phys. Res.* 218 (1983) 177
- 1983AN18 M.N. Andronenko, E.N. Volnin, A.A. Vorobev, V.T. Grachev, A.A. Lobodenko, I.I. Straskovsky and L.N. Uvarov, *Pisma Zh. Eksp. Teor. Fiz.* 37 (1983) 446; *JETP Lett. (USSR)* 37 (1983) 530

- 1983ANZQ Y. Ando, M. Uno and M. Yamada, JAERI-M-83-025 (1983)
- 1983AS03 J. Asher and M.T. Swinhoe, Nucl. Instrum. Meth. 213 (1983) 503
- 1983AS05 T. Asano, Y. Asano, Y. Iguchi, H. Kudo, S. Mori, M. Noguchi, Y. Takada, H. Hirabayashi, H. Ikeda, K. Katoh et al., Phys. Rev. C28 (1983) 1718
- 1983AS1B Aslanides et al., in Florence (1983) 642
- 1983AS1C Aslanides et al., in Florence (1983) 643
- 1983AS1D Asghar et al., in Florence (1983) 454
- 1983AU1B N. Auerbach, Phys. Rept. 98 (1983) 273
- 1983BA15 D.P. Balamuth, L. Brown, T.E. Chapuran, J. Klein, R. Middleton and R.W. Zurmuhle, Phys. Rev. C27 (1983) 1724
- 1983BA1A Backenstoss et al., in Florence (1983) 372
- 1983BA1G G. Backenstoss, M. Dorr, D. Gotta, W. Kowald, J. Reich, G. Schmidt, H. Ullrich and H.-J. Weyer, SIN Newsl. (Switzerland) 15 (1983) 31
- 1983BA1M Barnes et al., in Florence (1983) 389
- 1983BA26 P.D. Barnes, B. Bassalleck, R.A. Eisenstein, G. Franklin, R. Grace, C. Maher, P. Pile, R. Rieder, J. Szymanski, W.R. Wharton et al., Nucl. Phys. A402 (1983) 397
- 1983BA71 C.J. Batty, Nucl. Phys. A411 (1983) 399
- 1983BE1A Bernstein, Bertozzi and Kowalski, in Florence (1983) 579
- 1983BE45 R. Bergere, Nuovo Cim. A76 (1983) 147
- 1983BI13 J.R. Birkelund and J.R. Juizenga, Ann. Rev. Nucl. Part. Sci. 33 (1983) 265
- 1983BO1B O. Bohigas, Prog. Theor. Phys. Suppl. 74-75 (1983) 380
- 1983BR32 F. Brady, G.A. Needham, J.L. Romero, C.M. Castaneda, T.D. Ford, J.L. Ullmann and M.L. Webb, Phys. Rev. Lett. 51 (1983) 1320
- 1983BU1A Burkova and Zhusupov, in Florence (1983) 345
- 1983BU1B Burger, Hofmann, Kellerman and Mertelmeier, in Florence (1983) 57
- 1983CH1B Chant, AIP Conf. Proc. 97 (1983) 205
- 1983CH23 B. Chambon, D. Drain, C. Pastor, A. Dauchy, A. Giorni and C. Morand, Z. Phys. A312 (1983) 125
- 1983CO1E H. Conde, T. Andersson, L. Nilsson and C. Nordborg, in Antwerp (1983) 447
- 1983DA14 C.N. Davids, A.J. Elwyn, B.W. Filippone, S.B. Kaufman, K.E. Rehm and J.P. Schiffer, Phys. Rev. C28 (1983) 885
- 1983DA22 J.H. Dave and C.R. Gould, Phys. Rev. C28 (1983) 2212
- 1983DO07 T.R. Donoghue, E. Sugarbaker, M. Wiescher, T.C. Rinckel, K.E. Sale, C.P. Browne, E.D. Berners, R.W. Tarara and R.E. Warner, Phys. Rev. C28 (1983) 875

- 1983EF1A V.I. Efremenko, *Yad. Fiz.* 37 (1983) 118; *Sov. J. Nucl. Phys.* 37 (1983) 66
- 1983EN04 Y.M. Engel and R.D. Levine, *Phys. Rev. C*28 (1983) 2321
- 1983FA17 M.A. Fawzy, A.A. Azzam and A.M. Abd El-Monim, *Indian J. Phys.* A57 (1983) 378
- 1983FE07 V.N. Fetisov, L. Majling, J. Zofka and R.A. Eramzhyan, *Z. Phys.* A314 (1983) 239
- 1983FI09 G.F. Filippov, L.L. Chopovsky and V.S. Vasilevsky, *Yad. Fiz.* 37 (1983) 839; *Sov. J. Nucl. Phys.* 37 (1983) 500
- 1983FI11 G.F. Filippov, V.S. Vasilevsky and A.V. Nesterov, *Yad. Fiz.* 38 (1983) 584; *Sov. J. Nucl. Phys.* 38 (1983) 347
- 1983FI1C D. Fink, *Nucl. Instrum. Meth. Phys. Res.* 218 (1983) 456
- 1983FO1A Fowler, *AIP Conf. Proc.* 96 (1983) 80
- 1983FU11 Y. Fujiwara and Y.C. Tang, *Phys. Rev. C*28 (1983) 1869
- 1983FU19 Y. Fujiwara and Y.C. Tang, *Phys. Lett.* B131 (1983) 261
- 1983FU1D Y. Fujiwara, Y.C. Tang and H. Horiuchi, *Prog. Theor. Phys.* 70 (1983) 809
- 1983GE12 P.M. Gensini, *Lett. Nuovo Cim.* 38 (1983) 469
- 1983GE13 P.M. Gensini, *Lett. Nuovo Cim.* 38 (1983) 620
- 1983GE1C P.M. Gensini, *Nuovo Cim* A78 (1983) 471
- 1983GLZZ C.W. Glover, C.C. Foster, P. Schwandt, J.R. Comfort, J. Rapaport, T.N. Taddeucci, D. Wong, J. Seubert and G. Wagner, *Bull. Amer. Phys. Soc.* 28 (1983) 996, EC3
- 1983GM1A M. Gmitro, H.R. Kissener, P. Truol and R.A. Eramzhyan, *Fiz. Elem. Chastits At. Yadra* 14 (1983) 773; *Sov. J. Part. Nucl.* 14 (1983) 323
- 1983GO06 O.K. Gorpnich, E.P. Kadkin, S.N. Kondratev, Yu.N. Lobach, M.V. Pasechnik, L.S. Saltykov and V.V. Tokarevsky, *Izv. Akad. Nauk SSSR Ser. Fiz.* 47 (1983) 185; *Bull. Acad. Sci. USSR Phys. Ser.* 47 (1983) 179
- 1983GO1H C.R. Gould, J. Dave and R.L. Walter, in *Antwerp* (1983) 766
- 1983GU1A C. Guet, *Nucl. Phys.* A400 (1983) 191
- 1983GU1B Guinet et al., in *Florence* (1983) 531
- 1983HA1B M.J. Harris, W.A. Fowler, G.R. Caughlin and B.A. Zimmerman, *Ann. Rev. Astron. Astrophys.* 21 (1983) 165
- 1983HA1H Hanna, in *Florence* (1983) 473
- 1983HAYX G.M. Hale, D.C. Dodder and J.C. DeVeaux, in *Antwerp* (1983) 326
- 1983HE17 P. Heusi, H.P. Isaak, H.S. Pruijs, R. Engfer, E.A. Hermes, T. Kozlowski, U. Sennhauser and H.K. Walter, *Nucl. Phys.* A407 (1983) 429
- 1983HO22 H.M. Hofmann, T. Mertelmeier and W. Zahn, *Nucl. Phys.* A410 (1983) 208
- 1983KA19 W.B. Kaufmann and W.R. Gibbs, *Phys. Rev. C*28 (1983) 1286

- 1983KA37 S.G. Kadmskiy and Yu.L. Ratis, *Izv. Akad. Nauk SSSR Ser. Fiz.* 47 (1983) 2254; *Bull. Acad. Sci. USSR Phys. Ser.* 47 (1983) 162
- 1983KH04 S.A.E. Khallaf, *J. Phys. G9* (1983) 1377
- 1983KH1A S.A.E. Khallaf, *Atomkernenerg. Kerntech.* 42 (1983) 126
- 1983KI1B King et al., in *Orsay* (1983) 82
- 1983KN03 H.-H. Knitter, C. Budtz-Jorgensen, D.L. Smith and D. Marletta, *Nucl. Sci. Eng.* 83 (1983) 229
- 1983KN06 H.D. Knox and R.O. Lane, *Nucl. Phys. A403* (1983) 205
- 1983KN10 D.A. Knapp, A.B. McDonald and C.L. Bennett, *Nucl. Phys. A411* (1983) 195
- 1983KN1D Knitter, Budtz-Jorgensen and Smith, in *Antwerp* (1983) 451
- 1983KO17 L. Koester, K. Knopf and W. Waschkowski, *Z. Phys. A312* (1983) 81
- 1983KR10 J. Kronenfeld, A. Gal and J.M. Eisenberg, *Nucl. Phys. A402* (1983) 569
- 1983KU17 N. Kumar, *Nucl. Phys. A410* (1983) 50
- 1983KU1B A.A. Kuznetsov, *Nucl. Phys. A400* (1983) 493
- 1983KU1C Kutschera, *Radiocarbon* 25 (1983) 677
- 1983LE1F J.R. Letaw, *Phys. Rev. C28* (1983) 2178
- 1983LO09 R.G. Lovas, K.F. Pal and M.A. Nagarajan, *Nucl. Phys. A402* (1983) 141
- 1983MA34 G.J. Mathews, R.C. Haight, R.G. Lanier and R.M. White, *Phys. Rev. C28* (1983) 879
- 1983MA53 J.F. Mateja, J. Garman and A.D. Frawley, *Phys. Rev. C28* (1983) 1579
- 1983MA64 M. May, S. Bart, S. Chen, R.E. Chrien, D. Maurizio, P. Pile, Y. Xu, R. Hackenburg, E. Hungerford, H. Piekarczyk et al., *Phys. Rev. Lett.* 51 (1983) 2085
- 1983MO1C T. Motoba, H. Bando and K. Ikeda, *Prog. Theor. Phys.* 70 (1983) 189
- 1983MU08 M.J. Murphy and R.G. Stokstad, *Phys. Rev. C28* (1983) 428
- 1983NA08 M.N. Namboodiri, R.K. Choudhury, J.B. Natowitz, K. Hagel, L. Adler, P.L. Gonthier, H. Simon, S. Kniffen, R. Patton, E. Tomasi et al., *Phys. Rev. C28* (1983) 460
- 1983NA18 I. Navon, D. Ashery, J. Alster, G. Azuelos, B.M. Barnett, W. Gyles, R.R. Johnson, D.R. Gill and T.G. Masterson, *Phys. Rev. C28* (1983) 2548
- 1983NO03 E.B. Norman, T.E. Chupp, K.T. Lesko, J.L. Osborne, P.J. Grant and G.L. Woodruff, *Phys. Rev. C27* (1983) 1728; *Erratum Phys. Rev. C28* (1983) 1409
- 1983NO08 E. Norbeck, P.T. Wu, C.R. Chen and R.R. Carlson, *Phys. Rev. C28* (1983) 1140
- 1983OL1A D.L. Olson, B.L. Berman, D.E. Greiner, H.H. Heckman, P.J. Lindstrom and H.J. Crawford, *Phys. Rev. C28* (1983) 1602
- 1983OS04 R. Ostojic, K. Subotic and B. Stepanic, *Nuovo Cim. A76* (1983) 73

- 1983PA06 K.F. Pal, R.G. Lovas, M.A. Nagarajan, B. Gyarmati and T. Vertse, Nucl. Phys. A402 (1983) 114
- 1983PE14 R.J. Peterson, Phys. Scr. T5 (1983) 190
- 1983PO1B Poppe et al., AIP Conf. Proc. 97 (1983) 226
- 1983POZX C.H. Poppe, D. Rowley and F.S. Dietrich, Bull. Amer. Phys. Soc. 28 (1983) 969, AD8
- 1983RA1C Rapaport, AIP Conf. Proc. 97 (1983) 365
- 1983RA1D G. Ramachadran and S.B. Patangi, Nucl. Phys. Solid State Phys. Symp., 22-27 Dec. 1983, Mysore, India (1983) 31
- 1983SE07 M.R. Sene, I. Anthony, D. Branford, A.G. Flowers, A.C. Shotter, C.H. Zimmerman, J.C. McGeorge, R.O. Owens and P.J. Thorley, Phys. Rev. Lett. 50 (1983) 1831
- 1983SE16 U. Sennhauser, E. Piasetzky, H.W. Baer, J.D. Bowman, M.D. Cooper, H.S. Matis, H.J. Ziock, J. Alster, A. Errell, M.A. Moinester et al., Phys. Rev. Lett. 51 (1983) 1324
- 1983SH1D V.K. Sharma, B. Singh and P.P. Singh, Nucl. Phys. Solid State Phys. Symp., 22-27 Dec. 1983, Mysore, India (1983) 21
- 1983SH1E Y.-J. Shi and F. Zhuang, Phys. Energ. Fortis Phys. Nucl. 7 (1983) 605
- 1983SH38 Y.-J. Shi, Phys. Rev. C28 (1983) 2452
- 1983SI1A R.H. Siemssen, Nucl. Phys. A400 (1983) 245
- 1983SI1B J.A. Simpson, Ann. Rev. Nucl. Part. Sci. 33 (1983) 323
- 1983SO08 L.G. Sobotka, M.L. Padgett, G.J. Wozniak, G. Guarino, A.J. Pacheco, L.G. Moretto, Y. Chan, R.G. Stokstad, I. Tserruya and S. Wald, Phys. Rev. Lett. 51 (1983) 2187
- 1983SP06 Ts.P. Spasov, Ch.M. Chernev, Yu.A. Batusov and R.A. Eramzhyan, Bulg. J. Phys. 10 (1983) 581
- 1983SR1B K. Srinivasa Rao and J. Srinivasan, Nucl. Phys. Solid State Phys. Symp., 22-27 Dec. 1983, Mysore, India (1983) 21
- 1983SR1C K. Srinivasa Rao and J. Srinivasan, Nucl. Phys. Solid State Phys. Symp., 22-27 Dec. 1983, Mysore, India (1983) 22
- 1983ST1A H. Stocker, G. Buchwald, G. Graebner, P. Subramanian, J.A. Maruhn, W. Greiner, B.V. Jacak and G.D. Westfall, Nucl. Phys. A400 (1983) 63
- 1983STZS M.N. Stephens and K.W. Kemper, Bull. Amer. Phys. Soc. 28 (1983) 994, EB1
- 1983SZZY J. Szabo, M. Varnagy, Z.T. Body and J. Csikai, Proc. Int. Conf. Nucl. Data for Sci. and Technology, Geel, Belgium, 1982; Ed., K.H. Bockhoff (1983) 956
- 1983TAZY T.N. Taddeucci, J. Rapaport, C.D. Goodman, C.C. Foster, C.A. Goulding, C. Gaarde, J. Larsen, D.J. Horen, T. Masterson, E. Sugarbaker et al., Bull. Amer. Phys. Soc. 28 (1983) 714, GE6
- 1983UT01 H. Utsunomiya, S. Kubono, M.H. Tanaka, M. Sugitani, K. Morita, T. Nomura and Y. Hamajima, Phys. Rev. C28 (1983) 1975

- 1983VA31 A.G.M. van Hees and P.W.M. Glaudemans, *Z. Phys.* A314 (1983) 323
- 1983VE10 V.A. Vesna, A.I. Egorov, E.A. Kolomensky, V.M. Lobashev, I.S. Okunev, B.G. Peskov, A.N. Pirozhkov, L.M. Smotritsky, E.V. Shulgina, A.F. Korniyushkin et al., *Pisma Zh. Eksp. Teor. Fiz.* 38 (1983) 265; *JETP Lett.* 38 (1983) 315
- 1983VO1C Vogel, in *Symmetries in Nucl. Struct.*, Eds., Abrahams, Allaart and Dieperink (1983) 203
- 1983WA13 H. Walliser, Q.K.K. Liu, H. Kanada and Y.C. Tang, *Phys. Rev.* C28 (1983) 57
- 1983WA19 R. Wadsworth, M.D. Cohler, M.J. Smithson, D.L. Watson, F. Jundt, L. Kraus, I. Linck and J.C. Sens, *J. Phys.* G9 (1983) 1237
- 1983WA1H Wagoner, in *Florence* (1983) 741
- 1983WA1J H. Walliser, Y.C. Tang, B. Buck and S.M. Perez, *Phys. Rev. Lett.* 41 (1983) 1495
- 1984ABZY B.M. Abramov, I.A. Dukhovskoi, V.V. Kishkurno, L.A. Kondratyuk, A.P. Krutenkova, V.V. Kulikov, M.A. Matsyuk, P.A. Murat, I.A. Radkevich, E.N. Turdakina et al., in *Alma Ata* (1984) 311
- 1984AI1A Aivazyan et al., in *Panic* (1984) N6
- 1984AJ01 F. Ajzenberg-Selove, *Nucl. Phys.* A413 (1984) 1
- 1984AL24 T.K. Alexander, G.C. Ball, W.N. Lennard, H. Geissel and H.-B. Mak, *Nucl. Phys.* A427 (1984) 526
- 1984AN16 Yu.P. Antufyev, A.S. Deineko, I.I. Zalyubovsky, V.D. Sarana, V.E. Storizhko, A.I. Tutubalin, C. Hategan and N.A. Schliakhov, *Yad. Fiz.* 40 (1984) 53; *Sov. J. Nucl. Phys.* 40 (1984) 35
- 1984AN1B Anagnostatos, in *Panic* (1984) I56
- 1984AS1D F. Asai, H. Bando and M. Sano, *Phys. Lett.* B145 (1984) 19
- 1984AV07 M. Avan, A. Baldit, J. Castor, G. Chaigne, A. Devaux, J. Fargeix, P. Force, G. Landaud, G. Roche, J. Vicente et al., *Phys. Rev.* C30 (1984) 521
- 1984BA1M P.D. Barnes, *AIP Conf. Proc.* 123 (1984) 265
- 1984BA1T Bayukov et al., in *Panic* (1984) I16
- 1984BA1U Bayukov et al., in *Panic* (1984) I25
- 1984BA53 J. Bang, F.A. Gareev, S.A. Goncharov and G.S. Kazacha, *Nucl. Phys.* A429 (1984) 330
- 1984BE1C Belozarov et al., in *Alma Ata* (1984) 379
- 1984BE1E Benenson, *Bull. Amer. Phys. Soc.* 29 (1984) 1046
- 1984BE35 V. Bernard, J. Girard, J. Julien, R. Legrain, J. Poitou, A. Oskarsson, L. Carlen, H.-A. Gustafsson, B. Jakobsson, P. Kristiansson et al., *Nucl. Phys.* A423 (1984) 511

- 1984BL21 L.D. Blokhintsev, A.M. Mukjamedzhanov and A.N. Safronov, *Fiz. Elem. Chastits At. Yad.* 15 (1984) 1296; *Sov. J. Part. Nucl* 15 (1984) 580
- 1984BO1C Boyd, Turner, Rybarcyk and Joseph, Private Communication (1984)
- 1984BO1H L.N. Bogdanova and V.E. Markushin, *Fiz. Elem. Chastits At. Yadra* 15 (1984) 808; *Sov. J. Part. Nucl.* 15 (1984) 361
- 1984BR03 F.P. Brady, G.A. Needham, J.L. Ullmann, C.M. Castaneda, T.D. Ford, N.S.P. King, J.L. Romero, M.L. Webb, V.R. Brown and C.H. Poppe, *J. Phys.* G10 (1984) 363
- 1984BR22 T. Bressani, E. Chiavassa, S. Costa, G. Dellacasa, N. De Marco, M. Gallio, A. Musso, E. Aslanides, G. Bergdolt, P. Fassnacht et al., *Phys. Rev.* C30 (1984) 1745
- 1984BR32 F.P. Brady, T.D. Ford, G.A. Needham, J.L. Romero, C.M. Castaneda and M.L. Webb, *Nucl. Instrum. Meth. Phys. Res.* A228 (1984) 89
- 1984BU1D Burkova, Zhusupov and Imamkekov, in *Alma Ata* (1984) 421
- 1984CA1D T.A. Cahill, Y. Matsuda, D. Shadoan, R.A. Eldred and B.H. Kusko, *Nucl. Instrum. Meth. Phys. Res.* B231 (1984) 263
- 1984CH1G H.Z. Chen, F. Zhuang, X.J. Shi and X.N. Jin, *Chin. J. Nucl. Phys.* 6 (1984) 303
- 1984CH1H R.E. Chrien, *AIP Conf. Proc.* 123 (1984) 841
- 1984CH24 Y. Chang and M.R. Meder, *Phys. Rev.* C30 (1984) 1320
- 1984CO20 J. Cook, K.W. Kemper, P.V. Drumm, L.K. Fifield, M.A.C. Hotchkis, T.R. Ophel and C.L. Woods, *Phys. Rev.* C30 (1984) 1538
- 1984DA07 T. Davinson, V. Rapp, A.C. Shotter, D. Branford, M.A. Nagarajan, I.J. Thompson and N.E. Sanderson, *Phys. Lett.* B139 (1984) 150
- 1984DA1H R. Davis, Jr., B.T. Cleveland and J.K. Rowley, *AIP Conf. Proc.* 123 (1984) 1037
- 1984DE53 P. De Bievre, M. Gallet, N.E. Holden and I.L. Barnes, *J. Phys. Chem. Ref. Data* 13 (1984) 809
- 1984DO20 T.W. Donnelly and I. Sick, *Rev. Mod. Phys.* 56 (1984) 461
- 1984DU13 S.B. Dubovitchenko and M.A. Zhusupov, *Yad. Fiz.* 39 (1984) 1378; *Sov. J. Nucl. Phys.* 39 (1984) 870
- 1984DU17 S.B. Dubovichenko and M.A. Zhusupov, *Izv. Akad. Nauk SSSR Ser. Fiz.* 48 (1984) 935; *Bull. Acad. Sci. USSR Phys. Ser.* 48 (1984) 95
- 1984EC01 J.S. Eck, K.W. Kemper and T.R. Ophel, *Nucl. Phys.* A425 (1984) 141
- 1984EN1A P. Englert, S. Theis, R. Michel, C. Tuniz, R.K. Moniot, S. Vajda, T.H. Kruse, D.K. Pal and G.F. Herzog, *Nucl. Instrum. Meth. Phys. Res.* B233 (1984) 415
- 1984EV01 H.C. Evans, I.P. Johnstone, J.R. Leslie, W. McLatchie, H.-B. Mak, P. Skensved and T.K. Alexander, *Can. J. Phys.* 62 (1984) 1139
- 1984FE1A Ferch et al., *INDC (CCP)-221/L* (1984) 18

- 1984FI10 S.A. Fisher and R.L. Hershberger, Nucl. Phys. A423 (1984) 121
- 1984FI20 G.F. Filippov, V.S. Vasilevskii and A.V. Nesterov, Yad. Fiz. 40 (1984) 1418; Sov. J. Nucl. Phys. 40 (1984) 901
- 1984FR13 H. Friedrich, Phys. Lett. B146 (1984) 135
- 1984FU04 Y. Fujiwara and Y.C. Tang, Phys. Rev. C29 (1984) 2025
- 1984GE05 J.-F. Germond and C. Wilkin, J. Phys. G10 (1984) 745
- 1984GL06 Yu.A. Glukhov, A.S. Demyanova, A.A. Ogloblin, S.B. Sakuta and V.V. Sukharevsky, Yad. Fiz. 40 (1984) 62; Sov. J. Nucl. Phys. 40 (1984) 41
- 1984GO03 A. Gokmen, H. Breuer, A.C. Mignerey, B.G. Glagola, K. Kwiatkowski and V.E. Viola, Jr., Phys. Rev. C29 (1984) 1595
- 1984GR05 G. Grawert and D. Mukhopadhyay, Nucl. Phys. A415 (1984) 304
- 1984GR08 R.E.L. Green, R.G. Korteling and K.P. Jackson, Phys. Rev. C29 (1984) 1806
- 1984GU06 R. Guigas, P. Blum, H. Koch, M. Meyer, H. Poth, U. Raich, B. Richter, G. Backenstoss, P. Pavlopoulos, L. Tauscher et al., Phys. Lett. B137 (1984) 323
- 1984GU14 P.C. Gugelot, Phys. Rev. C30 (1984) 654
- 1984HA1B Hampel, Nature 308 (1984) 312
- 1984HA1D D. Halderson, Phys. Rev. C30 (1984) 941
- 1984HA1M W.C. Haxton, AIP Conf. Proc. 123 (1984) 1026
- 1984HA53 Q. Haider and F.B. Malik, At. Data Nucl. Data Tables 31 (1984) 185
- 1984HI1A A.S. Hirsch, A. Bujak, J.E. Finn, L.J. Gutay, R.W. Minich, N.T. Porile, R.P. Scharenberg and B.C. Stringfellow, Phys. Rev. C29 (1984) 508
- 1984HO1C H.M. Hofmann, Nucl. Phys. A416 (1984) 363
- 1984HU1C Hupke et al., in Panic (1984) I50
- 1984IS02 A.Z.M. Ismail, M.S. El-Nagdy, K.L. Gomber, M.M. Aggarwal and P.L. Jai, Phys. Rev. Lett. 52 (1984) 1280
- 1984IW01 Z.R. Iwinski, L. Rosenberg and L. Spruch, Phys. Rev. C29 (1984) 349
- 1984JEZZ R.G. Jeppesen, P.N. Craig, D.A. Lind, J.R. Shepard, J.L. Ullmann, C.D. Zafiratos, C.A. Goulding, N.S.P. King, P.W. Lisowski, G.L. Morgan et al., Bull. Amer. Phys. Soc. 29 (1984) 628, AF12
- 1984JI03 R.I. Jibuti and R.Ya. Kezerashvili, Nucl. Phys. A430 (1984) 573
- 1984JO1A Johnson, Proc. 4th Int. Conf. Clustering Aspects of Nucl. Struct., Chester, England, 1984 (1985) 155
- 1984KA01 T. Kajino and A. Arima, Phys. Rev. Lett. 52 (1984) 739
- 1984KA04 T. Kajino, T. Matsuse and A. Arima, Nucl. Phys. A414 (1984) 185

- 1984KA06 T. Kajino, T. Matsuse and A. Arima, Nucl. Phys. A413 (1984) 323
- 1984KE1B Kegel, Ciarcia, Egan and McGinness, Bull. Amer. Phys. Soc. 29 (1984) 118
- 1984KR10 V.M. Krasnopolskii, V.I. Kukul'in and V.G. Neudachin, Izv. Akad. Nauk SSSR Ser. Fiz. 48 (1984) 84; Bull. Acad. Sci. USSR Phys. Ser. 48 (1984) 82
- 1984KR1B A.V. Kravtsov, N.P. Popov and G.E. Solvakin, Pisma Zh. Eksp. Teor. Fiz. 40 (1984) 124; JETP Lett. (USSR) 40 (1984) 875
- 1984LO09 R.G. Lovas and K.F. Pal, Nucl. Phys. A424 (1984) 143
- 1984LO1C Lovas, Proc. 4th Int. Conf. Clustering Aspects of Nucl. Struct., Chester, England, 1984 (1985) 231
- 1984MA28 J.F. Mateja, J. Garman, D.E. Fields, R.L. Kozub, A.D. Frawley and L.C. Dennis, Phys. Rev. C30 (1984) 134
- 1984MI1C Millener, Gal, Dover and Dalitz, in Panic (1984) M7
- 1984MI1E D.J. Millener, AIP Conf. Proc. 123 (1984) 850
- 1984MI1F Mihailovic, Proc. 4th Int. Conf. Clustering Aspects of Nucl. Struct., Chester, England, 1984 (1985) 85
- 1984MIZM I.A. Mitropolsky and E.F. Hefter, in Alma Ata (1984) 241
- 1984MO06 Z. Moroz, K. Rusek, P. Egelhof, S. Kossionides, K.-H. Mobius, G. Tungate, E. Stefens, G. Grawert, I. Koenig and D. Fick, Nucl. Phys. A417 (1984) 498
- 1984MO09 T. Motoba, H. Bando and K. Ikeda, Prog. Theor. Phys. 71 (1984) 222
- 1984MO1D J.A. Montgomery, K.-B. Yoo, H. Uberall and B. Bosco, Can. J. Phys. 62 (1984) 764
- 1984MO1H T. Motoba, H. Bando and K. Ikeda, Proc. Int. Summer School, Changchun, China, 1983 (1984) 702
- 1984MO29 D.J. Morrissey, W. Benenson, E. Kashy, B. Sherrill, A.D. Panagiotou, R.A. Blue, R.M. Ronningen, J. van der Plicht and H. Utsunomiya, Phys. Lett. B148 (1984) 423
- 1984NE05 O.F. Nemets, V.V. Ostashko, O.M. Povoroznik, V.N. Urin, A.M. Yasnogorodsky, I.Ya. Barit and S.V. Zuev, Yad. Fiz. 40 (1984) 43; Sov. J. Nucl. Phys. 40 (1984) 28
- 1984NE1A Nemets, Rudchik and Chuvil'ski, in Alma Ata (1984) 334
- 1984NE1B Newman, Fisher and Thomas, Bull. Amer. Phys. Soc. 29 (1984) 1309
- 1984NI01 H. Nishioka, J.A. Tostevin, R.C. Johnson and K.-I. Kubo, Nucl. Phys. A415 (1984) 230
- 1984OH01 H. Ohnishi, M. Tanifuji, M. Kamimura, Y. Sakuragi and M. Yahiro, Nucl. Phys. A415 (1984) 271
- 1984OS03 J.L. Osborne, C.A. Barnes, R.W. Kavanagh, R.M. Kremer, G.J. Mathews, J.L. Zyskind, P.D. Parker and A.J. Howard, Nucl. Phys. A419 (1984) 115
- 1984PA1B Pasechnik et al., in Alma Ata (1984) 288

- 1984PE12 F. Petrovich, R.J. Philpott, A.W. Carpenter and J.A. Carr, Nucl. Phys. A425 (1984) 609
- 1984RA1E N.C. Rana, Nuovo Cim. B84 (1984) 53
- 1984RE14 S.M. Read and V.E. Viola, Jr., At. Data Nucl. Data Tables 31 (1984) 359
- 1984REZZ D.S. Resler, H.D. Knox, R.O. Lane and S.M. Grimes, Bull. Amer. Phys. Soc. 29 (1984) 629, AG3
- 1984RO1B Romanov and Grechukhin, in Alma Ata (1984) 280, 281
- 1984SA1E D.C. Santry and R.D. Werner. Nucl. Instrum. Meth. Phys. Res. B233 (1984) 449
- 1984SA39 L. Satta, J. Duflo, F. Plouin, P. Picozza, L. Goldzahl, J. Banaigs, R. Frascaria, F.L. Fabbri, A. Codino, J. Berge et al., Phys. Lett. B139 (1984) 263
- 1984SH01 G.R. Shen, S.L. Wen, T.Z. Huang, A.L. Li and X.X. Bai, Nucl. Sci. Eng. 86 (1984) 184
- 1984SH17 A.C. Shotter, V. Rapp, T. Davinson, D. Branford, N.E. Sanderson and M.A. Nagarajan, Phys. Rev. Lett. 53 (1984) 1539
- 1984SH1C K. Shibata, Rept. JAERI-M-84-198 (1984)
- 1984SH1D Shvedov, Dobrikov and Nemets, in Alma Ata (1984) 331
- 1984SH1J M. Shoeb and M.Z. Khan, J. Phys. G10 (1984) 1047
- 1984SH26 V.K. Sharma and M.A. Nagarajan, J. Phys. G10 (1984) 1703
- 1984SI15 S.H. Simon, P.L. Gonthier, R.K. Choudhury, M.N. Namboodiri, K. Hagel, S. Kniffen, R. Patton, L. Adler and J.B. Natowitz, Nucl. Phys. A430 (1984) 249
- 1984SK01 R.T. Skelton and R.W. Kavanagh, Nucl. Phys. A414 (1984) 141
- 1984ST1B R.G. Stokstad, Comments on Nucl. Part. Phys. 13 (1984) 231
- 1984SU09 D. Sundholm, P. Pyykko, L. Laaksonen and A. Sadlej, Chem. Phys. Lett. 112 (1984) 1
- 1984SU1A Sur and Boyd, Private Communication (1984)
- 1984TA07 T.N. Taddeucci, T.A. Carey, C. Gaarde, J. Larsen, C.D. Goodman, D.J. Horen, T. Masterson, J. Rapaport, T.P. Welch and E. Sugarbaker, Phys. Rev. Lett. 52 (1984) 1960
- 1984TAZS T.N. Taddeucci, Bull. Amer. Phys. Soc. 29 (1984) 1032, BA4
- 1984TR1C J.W. Truran, Ann. Rev. Nucl. Part. Sci. 34 (1984) 53
- 1984UH1A M. Uhlig and A. Schafer, Z. Phys. A319 (1984) 97
- 1984VA06 A.G.M. van Hees and P.W.M. Glaudemans, Z. Phys. A315 (1984) 223
- 1984VAZS V.S. Vasilevsky, S.P. Kruchinin, G.F. Filippov and L.L. Chopovsky, in Alma Ata (1984) 463

- 1984VE03 W.J. Vermeer, M.T. Esat, M.P. Fewell, R.H. Spear, A.M. Baxter and S.M. Burnett, Phys. Lett. B138 (1984) 365
- 1984VE08 W.J. Vermeer, A.M. Baxter, S.M. Burnett, M.T. Esat, M.P. Fewell and R.H. Spear, Aust. J. Phys. 37 (1984) 273
- 1984VEZW V.A. Vesna, A.I. Egorov, E.A. Kolomensky, A.F. Korniyushkin, V.M. Lobashev, I.S. Okunev, B.G. Peskov, A.N. Pirozhkov, L.M. Smotrisky, N.A. Titov, et al., in Alma Ata (1984) 310
- 1984VI02 M.F. Vineyard, J. Cook, K.W. Kemper and M.N. Stephens, Phys. Rev. C30 (1984) 916
- 1984WA02 H. Walliser and Y.C. Tang, Phys. Lett. B135 (1984) 344
- 1984WA06 H. Walliser, H. Kanada and Y.C. Tang, Nucl. Phys. A419 (1984) 133
- 1984WA11 H. Walliser, H. Kanada and Y.C. Tang, Phys. Rev. Lett. 53 (1984) 399
- 1984WA1H L.-H. Wang, F.-A. Zeng and X. Zhao, Phys. Energ. Fortis Phys. Nucl. 8 (1984) 328
- 1984XI1A Xiao, Kexue Tongbao 29 (1984) 234
- 1984XI1B Y.-X. Xie, Y.-T. Zhu, E.-P. Fen, X. Yin, H.-B. Miao, J.-X. Cai, F.-W. Li, W.-Q. Shen, S.-M. Sun, J.-J. Wei et al., Phys. Energ. Fortis Phys. Nucl. 8 (1984) 748
- 1984YA1A J. Yang, M.S. Turner, G. Steigman, D.N. Schramm and K.A. Olive, Astrophys. J. 281 (1984) 493
- 1984ZA07 N.I. Zaika, A.V. Mokhnach, A.T. Rudchik, V.S. Semenov, V.A. Shityuk and P.L. Shmarin, Yad. Fiz. 39 (1984) 1081; Sov. J. Nucl. Phys. 39 (1984) 682
- 1984ZA1A M. Zamani, K. Zioutas and S. Charalambous, Nucl. Tracks Radiat. Meas. 8 (1984) 555
- 1984ZH1B F. Zhuang, H.-Z. Chen and X.-N. Jin, Phys. Energ. Fortis Phys. Nucl. 8 (1984) 215
- 1984ZW1A Zwartz, Unpublished Ph.D. Thesis, Utrecht (1984)
- 1985AD1B Adichev et al., in Leningrad (1985) 373
- 1985AG1A M.M. Aggarwal and P.L. Jain, Phys. Rev. C31 (1985) 1233
- 1985AH1A I. Ahmad, M. Mian and M.Z. Rahman Khan, Phys. Rev. C31 (1985) 1590
- 1985AJ01 F. Ajzenberg-Selove, Nucl. Phys. A433 (1985) 1; Erratum Nucl. Phys. A449 (1986) 155
- 1985AL1G Aleksandrov et al., Questions in At. Phys. and in Tech., USSR (1985) 3
- 1985AL29 D.V. Aleksandrov, Yu.A. Glukhov, B.G. Novatsky, E.Yu. Nikolsky, A.A. Ogloblin and D.N. Stepanov, Izv. Akad. Nauk SSSR, Ser. Fiz. 49 (1985) 2115; Bull. Acad. Sci. USSR, Phys. Ser. 49 (1985) 30
- 1985ALZL D.V. Aleksandrov, E.A. Ganza, Yu.A. Glukhov, E.Yu. Nikolsky, B.G. Novatsky, A.A. Ogloblin, D.N. Stepanov, in Leningrad (1985) 355

- 1985ALZM D.V. Aleksandrov, Yu.A. Glukhov, E.Yu. Nikolsky, B.G. Novatsky, A.A. Ogloblin, D.N. Stepanov, in Leningrad (1985) 354
- 1985AN28 M.S. Antony, J. Britz, J.B. Bueb and A. Pape, *At. Data Nucl. Data Tables* 33 (1985) 447
- 1985BA1L Barchuk et al., in Leningrad (1985) 368
- 1985BA1M J.N. Bahcall, *Solar Phys.* 100 (1985) 53
- 1985BA1N J.N. Bahcall, *AIP Conf. Proc.* 126 (1985) 60
- 1985BA1Q D. Baye and P. Descouvemont, *Ann. Phys.* 165 (1985) 115
- 1985BA66 F.M. Baumann, B. Bruggemann, H. Freiesleben, Th. Grodotzki and H.Chr. Hilber, *Nucl. Instrum. Meth.* 238 (1985) 443
- 1985BA68 F.C. Barker and C.L. Woods, *Aust. J. Phys.* 38 (1985) 563
- 1985BE30 S.L. Belostotsky, S.S. Volkov, A.A. Vorobyev, Yu.V. Dotsenko, L.G. Kudin, N.P. Kuropatkin, O.V. Miklukho, V.N. Nikulin and O.E. Prokofyev, *Yad. Fiz.* 41 (1985) 1425; *Sov. J. Nucl. Phys.* 41 (1985) 903
- 1985BH02 R. Bhanja, M. Shyam and S.K. Tuli, *Nucl. Phys.* A438 (1985) 740
- 1985BL1B S.L. Blatt, *AIP Conf. Proc.* 125 (1985) 570
- 1985BO1D Body and Mihaly, *INDC (HUN)-22/L* (1985)
- 1985BO1E R.N. Boyd, R.E. Turner, B. Sur, L. Rybarchyk and C. Joseph, *AIP Conf. Proc.* 126 (1985) 145
- 1985BO1K Boesgaard and Steigman, *Ann. Rev. Astron. Astrophys.* 23 (1985) 319
- 1985BU02 B. Buck, R.A. Baldock and J.A. Rubio, *J. Phys. (London)* G11 (1985) L11
- 1985CA36 R.F. Carlson, A.J. Cox, T.N. Nasr, M.S. De Jong, D.L. Ginther, D.K. Hasell, A.M. Sourkes, W.T.H. Van Oers and D.J. Margaziotis, *Nucl. Phys.* A445 (1985) 57
- 1985CA41 G.R. Caughlan, W. A. Fowler, M.J. Harris and B.A. Zimmerman, *At. Data Nucl. Data Tables* 32 (1985) 197
- 1985CH37 S. Chiba, M. Baba, H. Nakashima, M. Ono, N. Yabuta, S. Yukinori and N. Hirakawa, *J. Nucl. Sci. Tech. (Tokyo)* 22 (1985) 771
- 1985CL1A F.E. Close, *Nucl. Phys.* A446 (1985) 273
- 1985CO09 J. Cook and K.W. Kemper, *Phys. Rev.* C31 (1985) 1745
- 1985CO18 A.J. Cox and P.C. Warner, *Int. J. Appl. Radiat. Isotop.* 36 (1985) 537
- 1985DE17 E. Descroix, M. Bedjidian, J.Y. Grossiord, A. Guichard, M. Gusakow, M. Jacquin, J.R. Pizzi and G. Bagieu, *Nucl. Phys.* A438 (1985) 112
- 1985DE1E A. De Rujula, *Nucl. Phys.* A434 (1985) 605
- 1985DE1H A. De Bellefon, P. Espigat and G. Waysand, *AIP Conf. Proc.* 126 (1985) 227

- 1985DE1K P. Delbourgo-Salvador, C. Gry, G. Malinie and J. Audouze, *Astron. Astrophys.* 150 (1985) 53
- 1985DI08 S.A. Dickey, J.J. Kraushaar and R.J. Peterson, *Z. Phys.* A320 (1985) 649
- 1985DO16 Yu.V. Dotsenko and V.E. Starodubsky, *Yad. Fiz.* 42 (1985) 107; *Sov. J. Nucl. Phys.* 42 (1985) 66
- 1985DU05 O. Dumbrajs, *Phys. Scr.* 31 (1985) 485
- 1985FA02 H. Faissner, B.R. Kim and H. Reithler, *Phys. Rev. Lett.* 54 (1985) 1902
- 1985FI1D B.W. Filippone, *AIP Conf. Proc.* 126 (1985) 100
- 1985FI1E G.F. Filippov, V.S. Vasilevskii and L.L. Chopovskii, *Fiz. Elem. Chastits At. Yadra* 16 (1985) 349; *Sov. J. Part. Nucl.* 16 (1985) 153
- 1985FR01 R. Franke, K. Kochskamper, B. Steinheuer, K. Wingender, W. Von Witsch and H. Machner, *Nucl. Phys.* A433 (1985) 351
- 1985FR1F V. Franco and Y. Yin, *Phys. Rev. Lett.* 55 (1985) 1059
- 1985FU01 Y. Fujiwara and Y.C. Tang, *Phys. Rev.* C31 (1985) 342
- 1985FU11 Y. Fujiwara and Y.C. Tang, *Phys. Rev.* C32 (1985) 1428
- 1985GA1C A. Gal, *AIP Conf. Proc.* 133 (1985) 30
- 1985GI1C R.L. Gilliland, *Astrophys. J.* 290 (1985) 344
- 1985GL06 Yu.A. Glukhov, A.S. Demyanova, A.A. Ogloblin, S.B. Sakuta, I. Berceanu and I. Mihai, *Yad. Fiz.* 42 (1985) 561; *Sov. J. Nucl. Phys.* 42 (1985) 355
- 1985GO11 J. Gomez-Camacho, M. Lozano and M.A. Nagarajan, *Nucl. Phys.* A440 (1985) 543
- 1985GO18 E. Goldberg, R.L. Barber, P.E. Barry, N.A. Bonner, J.E. Fontanilla, C.M. Griffith, R.C. Haight, D.R. Nethaway and G.B. Hudson, *Nucl. Sci. Eng.* 91 (1985) 173
- 1985GO1A N.G. Goncharova, H.-R. Kissener and R.A. Eramzhyan, *Fiz. Elem. Chastits At. Yadra* 16 (1985) 773; *Sov. J. Part. Nucl.* 16 (1985) 337
- 1985GO1F C.D. Goodman, *AIP Conf. Proc.* 124 (1985) 375
- 1985GO20 J. Gomez-Camacho, M. Lozano and M.A. Nagarajan, *Phys. Lett.* B161 (1985) 39
- 1985GO23 J. Gomez-Camacho and M.A. Nagarajan, *J. Phys.* G11 (1985) L239
- 1985HA05 H.J. Hausman, S.L. Blatt, R.N. Boyd, T.R. Donoghue, R.G. Seyler, D.G. Marchlenski, T.W. Rackers, P. Schmalbrock, L.G. Arnold, M.A. Kovash et al., *Phys. Rev.* C31 (1985) 660
- 1985HA18 S.S. Hanna and J.W. Hugg, *Hyperfine Interactions* 21 (1985) 59
- 1985HA1H E. Hayward, *AIP Conf. Proc.* 125 (1985) 131
- 1985HE25 K. Heck, G. Grawert and D. Mukhopadhyay, *Nucl. Phys.* A437 (1985) 226
- 1985HO1A L.M. Hobbs, *Astrophys. J.* 290 (1985) 284

- 1985IR01 F. Irom, H.W. Baer, J.D. Bowman, M.D. Cooper, E. Piasezky, U. Sennhauser, H.J. Ziock, M.J. Leitch, A. Erell, M.A. Moinester et al., Phys. Rev. C31 (1985) 1464
- 1985IR02 F. Irom, M.J. Leitch, H.W. Baer, J.D. Bowman, M.D. Cooper, B.J. Dropesky, E. Piasezky and J.N. Knudson, Phys. Rev. Lett. 55 (1985) 1862
- 1985JA09 L. Jarczyk, B. Kamys, A. Magiera, A. Strzalkowski, A. Szczurek, K. Bodek, M. Hugi, J. Lang, R. Muller and E. Ungricht, J. Phys. G11 (1985) 843
- 1985JA12 L. Jarczyk, B. Kamys, Z. Rudy, A. Strzalkowski, B. Styczen, G.P.A. Berg, A. Magiera, J. Meissburger, W. Oelert, P. von Rossen et al., Z. Phys. A322 (1985) 221
- 1985JA18 B.V. Jacak, D. Fox and G.D. Westfall, Phys. Rev. C31 (1985) 704
- 1985JE1A Jeppesen et al., Bull. Amer. Phys. Soc. 30 (1985) 784
- 1985KA01 M. Kawai and Y. Iseri, Phys. Rev. C31 (1985) 400
- 1985KA1D Kadkin, in Leningrad (1985) 297
- 1985KA1H T. Kajino, Lecture Notes in Phys. 219 (1985) 85
- 1985KA1K T. Kajino, J. Phys. Soc. Jpn. 54 Suppl. 2 (1985) 321
- 1985KE1D G.H.R. Kegel, Comput. Phys. Commun. 36 (1985) 321
- 1985KH08 S.A.E. Khallaf and H.M. Ali Ahmed, Fizika 17 (1985) 169
- 1985KI1C C.O. Kim, S.N. Kim, I.K. Chae and D.H. Kim, Phys. Rev. C32 (1985) 1454
- 1985KL1A H.V. Klapdor, Fortschr. Phys. 33 (1985) 1
- 1985KL1B H.-J. Kluge, Hyperfine Interact. 22 (1985) 559
- 1985KN1A Knyr, Mazur and Smirnov, in Leningrad (1985) 198
- 1985KO1G Kolesnikov, Zakharov, Kopilov and Tarasov, in Leningrad (1985) 199
- 1985KO29 Yu.E. Kozyr, V.I. Medvedev, Yu.N. Pavlenko and V.M. Pugach, Izv. Akad. Nauk SSSR, Ser. Fiz. 49 (1985) 1026; Bull. Acad. Sci. USSR, Phys. Ser. 49 (1985) 179
- 1985KO47 P.J.J. Kok, K. Abrahams, H. Postma and W.J. Huiskamp, Nucl. Instrum. Meth. Phys. Res. B12 (1985) 325
- 1985KR1B L. Krauss and F. Wilczek, Phys. Rev. Lett. 55 (1985) 122
- 1985KW02 E. Kwasniewicz and L. Jarczyk, Nucl. Phys. A441 (1985) 77
- 1985LA20 I.A. Lantsev, V.I. Ostroumov, Yu.R. Gismatulin, V.N. Zbarag and A.A. Melentev, Izv. Akad. Nauk SSSR Ser. Fiz. 49 (1985) 143; Bull. Acad. Sci. USSR Phys. Ser. 49 (1985) 149
- 1985LE19 Y. Le Bornec, L. Bimbot, M.P. Combes-Comets, J.C. Jourdain, F. Reide, A. Willis and N. Willis, J. Phys. G11 (1985) 1125
- 1985LI1F Y.-G. Ling and X. Zhao, Chin. Phys. 5 (1985) 77

- 1985MA02 H. Machner, D. Protic, G. Riepe, H.G. Bohlen and H. Fuchs, Phys. Rev. C31 (1985) 443
- 1985MA13 M.T. Magda, A. Pop and A. Sandulescu, J. Phys. G11 (1985) L75
- 1985MAZZ C.J. Martoff, D. Pocanic, L.W. Whitlow, S.S. Hanna, H. Ullrich, S. Cierjacks, M. Furic, T. Petkovic and H.J. Weyer, Bull. Amer. Phys. Soc. 30 (1985) 794, IF7
- 1985MC03 M.A. McMahan, L.G. Moretto, M.L. Padgett, G.J. Wozniak, L.G. Sobotka and M.G. Mustafa, Phys. Rev. Lett. 54 (1985) 1995
- 1985MI1E G. Michaud, AIP Conf. Proc. 126 (1985) 75
- 1985MO08 M. Morjean, J.L. Charvet, J.L. Uzureau, Y. Patin, A. Peghaire, Y. Pranal, L. Sinopoli, A. Billerey, A. Chevarier, N. Chevarier et al., Nucl. Phys. A438 (1985) 547
- 1985MO17 D.J. Morrissey, W. Benenson, E. Kashy, C. Bloch, M. Lowe, R.A. Blue, R.M. Ronningen, B. Sherrill, H. Utsunomiya and I. Kelson, Phys. Rev. C32 (1985) 877
- 1985MO1F T. Motoba, H. Bando, K. Ikeda and T. Yamada, Suppl. Prog. Theor. Phys. 81 (1985) 42
- 1985MO24 D.J. Morrissey, W. Benenson, E. Kashy, C. Bloch, M. Lowe, B. Sherrill, R.A. Blue, R.M. Ronningen and H. Utsunomiya, Nucl. Phys. A447 (1986) 603c
- 1985NE08 O.F. Nemets, V.V. Ostashko, V.N. Urin and A.M. Yasnogorodskii, Yad. Fiz. 42 (1985) 809; Sov. J. Nucl. Phys. 42 (1985) 512
- 1985PA03 M.V. Pasechnik, L.S. Saltykov, E.P. Kadkin, I.I. Loshchakov and A.I. Vdovin, Izv. Akad. Nauk SSSR Ser. Fiz. 49 (1985) 53; Bull. Acad. Sci. USSR Phys. Ser. 49 (1985) 55
- 1985PA04 M.V. Pasechnik, L.S. Saltykov, E.P. Kadkin, I.I. Loshchakov and A.I. Vdovin, Izv. Akad. Nauk SSSR, Ser. Fiz. 49 (1985) 58; Bull. Acad. Sci. USSR, Phys. Ser. 49 (1985) 61
- 1985PA1A J.C. Palathingal, AIP Conf. Proc. 125 (1985) 847
- 1985PA1B Pasechnik, in Leningrad (1985) 265
- 1985PAZL M.V. Pasechnik, L.S. Saltykov, E.P. Kadkin, I.I. Loshchakov and A.I. Vdovin, in Leningrad (1985) 296
- 1985PO10 N.A.F.M. Poppelier, L.D. Wood and P.W.M. Glaudemans, Phys. Lett. B157 (1985) 120
- 1985RE1A Repenko et al., in Leningrad (1985) 342
- 1985RU01 W. Ruckstuhl, B. Aas, W. Beer, I. Beltrami, K. Bos, G. De Chambrier, P.F.A. Goudsmit, H.J. Leisi, G. Strassner, A. Vacchi et al., Nucl. Phys. A433 (1985) 634
- 1985SA13 Y. Sakuragi, M. Kamimura, M. Yahiro and M. Tanifuji, Phys. Lett. B153 (1985) 372
- 1985SA25 D.P. Sanderson, S.P. Van Verst, J. Cook, K.W. Kemper and J.S. Eck, Phys. Rev. C32 (1985) 887

- 1985SA32 H. Sato and Y. Okuhara, Phys. Lett. B162 (1985) 217
- 1985SC1C Schramm, Nature 317 (1985) 386
- 1985SC1D R. Schaeffer, P. Delbourgo-Salvador and J. Audouze, Nature 317 (1985) 407
- 1985SE17 M.R. Sene, I. Anthony, D. Branford, A.G. Flowers, A.C. Shotter and C.H. Zimmerman, Nucl. Phys. A442 (1985) 215
- 1985SH1G W.-Q. Shen, W.-M. Qiao, Y.-T. Zhu and W.-L. Zhan, Chin. Phys. 5 (1985) 657
- 1985SH22 R. Shyam, R.G. Lovas, K.F. Pal, V.K. Sharma and M.A. Nagarajan, J. Phys. G11 (1985) 1199
- 1985ST1A Stibunov, in Leningrad (1985) 341
- 1985ST1B R.G. Stokstad, Treatise on Heavy-Ion Sci. 3 (1985) 83
- 1985SW01 M.T. Swinhoe and C.A. Uttley, Nucl. Sci. Eng. 89 (1985) 261
- 1985TA18 I. Tanihata, H. Hamagaki, O. Hashimoto, Y. Shida, N. Yoshikawa, K. Sugimoto, O. Yamakawa, T. Kobayashi and N. Takahashi, Phys. Rev. Lett. 55 (1985) 2676
- 1985TA1D I. Tanihata, Hyperfine Interactions 21 (1985) 251
- 1985TAZY T.N. Taddeucci, C.D. Goodman, C.C. Foster, R.C. Byrd, C. Gaarde, J.S. Larsen, D.J. Horen, J. Rapaport and E. Sugarbaker, Bull. Amer. Phys. Soc. 30 (1985) 1255, BB4
- 1985TR1B Trockel et al., in Visby (1985) 148
- 1985TU1A G. Tungate, W. Ott and H. Leucker, Z. Phys. A321 (1985) 103
- 1985WA17 H. Walliser and T. Fliessbach, Phys. Rev. C31 (1985) 2242
- 1985WA1F Waddington and Freier, in Visby (1985) 22
- 1985WA1K T.P. Walker, G.J. Mathews and V.E. Viola, Astrophys. J. 299 (1985) 745
- 1985WA22 S. Wald, S.B. Gazes, C.R. Albiston, Y. Chan, B.G. Harvey, M.J. Murphy, I. Tserruya, R.G. Stokstad, P.J. Countryman, K. Van Bibber et al., Phys. Rev. C32 (1985) 894
- 1985WE08 A. Weller, P. Egelhof, R. Caplar, O. Karban, D. Kramer, K.-H. Mobius, Z. Moroz, K. Rusek, E. Steffens, G. Tungate et al., Phys. Rev. Lett. 55 (1985) 480
- 1985WH1A R.E. White, P.H. Baker and D.M.J. Lovelock, Metrologia 21 (1985) 193
- 1985WO11 L.W. Woo, K. Kwiatkowski, S.H. Zhou and V.E. Viola, Phys. Rev. C32 (1985) 706
- 1986AB1E K. Abrahams, J. Phys. Soc. Jpn. Suppl. 55 (1986) 572
- 1986AH03 M.H. Ahsan and H.H. Thies, Nucl. Instrum. Meth. Phys. Res. A243 (1986) 523
- 1986AJ01 F. Ajzenberg-Selove, Nucl. Phys. A449 (1986) 1
- 1986AJ04 F. Ajzenberg-Selove, Nucl. Phys. A460 (1986) 1
- 1986AN1R H.H. Ansari, M. Shoeb and M.Z.R. Rahman Khan, J. Phys. G12 (1986) 1369
- 1986AN29 N. Anantaraman, J.S. Winfield, S.M. Austin, A. Galonsky, J. van der Plicht, C.C. Chang, G. Ciangaru and S. Gales, Phys. Rev. Lett. 57 (1986) 2375

- 1986AN40 M. Anikina, A. Golokhvastov, K. Iovchev, S. Khorozov, E. Kuznetsova, J. Lukstins, E. Okonov, T. Ostanevich, V. Toneev, G. Vardenga et al., Phys. Rev. C33 (1986) 895
- 1986AU1A V.E. Aushev, N.I. Zaika, Yu.V. Kibkalo, A.V. Mokhnach, G.G. Zaikin, A.A. Kluchnikov, A.A. Kozur, A.L. Taradanov, Yu.A. Chvanov and V.N. Scherbin, J. Phys. Soc. Jpn. Suppl. 55 (1986) 1074
- 1986AU1C Austin, Anant Araman and Winfield, MSUCL-578 (1986)
- 1986AU1D N. Auerbach, AIP Conf. Proc. 150 (1986) 520
- 1986AV07 A.R. Avakyan, G.A. Vartapetyan, E.O. Grigoryan and N.A. Demekhina, Yad. Fiz. 44 (1986) 566; Sov. J. Nucl. Phys. 44 (1986) 187
- 1986AV08 G.V. Avakov, L.D. Blokhintsev, T.D. Blokhintseva, V.P. Kurochkin and Zh.P. Pustyl'nik, Yad. Fiz. 44 (1986) 1471; Sov. J. Nucl. Phys. 44 (1986) 958
- 1986AV1A V.V. Avdeichikov, A.I. Bogdanov, V.A. Budilov, N.K. Zhidkov, N.L. Gorshkova, A. Kotus, Yu.A. Murin, V.A. Nikitin, P.V. Nomokonov and M.D. Traikova, Yad. Fiz. 44 (1986) 440; Sov. J. Nucl. Phys. 44 (1986) 282
- 1986AV1B Avdeichikov, in Dubna (1986) 122
- 1986BA1C H.W. Baer and G.A. Miller, Comments Nucl. and Part. Phys. 15 (1986) 269
- 1986BA1W H. Bando, Nucl. Phys. A450 (1986) 217c
- 1986BA2G Barlamov, Ishkanov, Chernyaev and Eramzhian, in Kharkov (1986) 345
- 1986BA2J Badalov, Belenskii and Filippov, in Kharkov (1986) 495
- 1986BA2N M. Balcazar, L. Tavera and E. Belmont, Nucl. Track Radiat. Meas. 12 (1986) 669
- 1986BA32 C.M. Bartle, Nucl. Instrum. Meth. Phys. Res. A244 (1986) 582
- 1986BA50 G. Baur, C.A. Bertulani and H. Rebel, Nucl. Phys. A458 (1986) 188
- 1986BA68 C.M. Bartle, Radiat. Eff. 95 (1986) 331
- 1986BA88 W. Bauhoff, At. Data Nucl. Data Tables 35 (1986) 429
- 1986BA89 G. Baur, Phys. Lett. B178 (1986) 135
- 1986BAYN R.A. Baldock, P.J.B. Hopkins and B. Buck, Proc. Int. Nucl. Phys. Conf., Harrogate, U.K. (1986) 410; C223
- 1986BE1H M. Betz, M. Haller, W. Kretschmer, H. Loh, F. Post, A. Rauscher, R. Schmitt, W. Schuster and D. Votisch, J. Phys. Soc. Jpn. Suppl. 55 (1986) 576
- 1986BE1J H. Bechtel and D. Fick, J. Phys. Soc. Jpn. Suppl. 55 (1986) 1082
- 1986BL12 C. Bloch, W. Benenson, E. Kashy, D.J. Morrissey, R.A. Blue, R.M. Ronningen and H. Utsunomiya, Phys. Rev. C34 (1986) 850
- 1986BO01 D.H. Boal and J.C. Shillcock, Phys. Rev. C33 (1986) 549
- 1986BO1H A.M. Boesgaard and R.J. Lavery, Astrophys. J. 309 (1986) 762

- 1986BOZG I.M. Bondarenko and E.E. Petrov, INDC(CCP)-265/L (1986)
- 1986BR1L J.M. Brock, A.P. Fewes and D.L. Henshaw, Nucl. Track Radiat. Meas. 12 (1986) 603
- 1986CA28 A.D. Carlson, W.P. Poenitz, G.M. Hale and R.W. Peelle, Radiat. Eff. 96 (1986) 87
- 1986CA29 A.D. Carlson, Radiat. Eff. 96 (1986) 109
- 1986CA30 L. Carlen, H.-A. Gustafsson, B. Jakobsson, A. Kristiansson, A. Oskarsson, H. Ryde, M. Westenius, J.P. Bondorf, O.-B. Nielsen, G. Lovhoiden et al., Phys. Scr. 34 (1986) 475
- 1986CE04 C. Cernigoi, N. Grion, G. Pauli, R. Rui and R. Cherubini, Nucl. Phys. A456 (1986) 599
- 1986CH1P R.E. Chrien, Czech. J. Phys. B36 (1986) 410
- 1986CH1Q P. Chaumette, J. Deregél, G. Durand, J. Fabre, J. Movchet, L. van Rossum, J. Ball, V. Bouffard, G. Fournier and Y. Roinel, Helv. Phys. Acta 59 (1986) 767
- 1986CH1S Cheng and Huang, in Santa Fe (1986) 231
- 1986CH24 S. Chiba, M. Baba, H. Nakashima, M. Ono, N. Yabuta, S. Yukinori and N. Hirakawa, Radiat. Eff. 92 (1986) 227
- 1986CL03 N.M. Clarke and J. Cook, Nucl. Phys. A458 (1986) 137
- 1986CL1B N.M. Clarke, P.J. Simmons, K.I. Pearce, S. Roman, A. Farooq and G. Rai, J. Phys. Soc. Jpn. Suppl. 55 (1986) 756
- 1986CO02 J. Cook, M.N. Stephens, K.W. Kemper and A.K. Abdallah, Phys. Rev. C33 (1986) 915
- 1986CO1H Cohn, Bull. Amer. Phys. Soc. 31 (1986) 830
- 1986CO1L Conde et al., Bull. Amer. Phys. Soc. 31 (1986) 1233
- 1986CO1M G. Constantine, L.J. Baker and N.P. Taylor, Nucl. Instrum. Meth. Phys. Res. A250 (1986) 565
- 1986CS1A L.P. Csernai and J.I. Kapusta, Phys. Rept. 131 (1986) 223
- 1986DA1B D.H. Davis and J. Pniewski, Contemp. Phys. 27 (1986) 91
- 1986DAZP T. Davinson, A.C. Shotton, V. Rapp and D. Branford, Proc. Int. Nucl. Phys. Conf., Harrogate, U.K. (1986) 402
- 1986DE1J L. De Barbaro, K.J. Heller and J. Szwed, J. Phys. Soc. Jpn. Suppl. 55 (1986) 962
- 1986DO01 C.B. Dover, A. Gal, L. Klieb and D.J. Millener, Phys. Rev. Lett. 56 (1986) 119
- 1986DO11 T.W. Donnelly and A.S. Raskin, Ann. Phys. 169 (1986) 247
- 1986DR10 M. Drosig, P.W. Lisowski, R.A. Hardekopf, D.M. Drake and K. Treitl, Radiat. Eff. 92 (1986) 145
- 1986DU03 E.I. DubovoI and G.I. Chitanava, Yad. Fiz. 43 (1986) 587; Sov. J. Nucl. Phys. 43 (1986) 373

- 1986DU10 O. Dumbrajs, H. Heiselberg, A.S. Jensen, A. Miranda, G.C. Oades and J.M. Richard, Nucl. Phys. A457 (1986) 491
- 1986DU1E Dushkesas and Makarionas, in Kharkov (1986) 247
- 1986EN1A Engelmann and Bardy, Rept. CEA-R-5340 (1986)
- 1986ER05 O.N. Ermakov, I.L. Karpikhin, P.A. Krupchitsky, G.A. Lobov, V.F. Perepelitsa, F. Stecher-Rasmussen and P. Kok, Yad. Fiz. 43 (1986) 1359; Sov. J. Nucl. Phys. 43 (1986) 874
- 1986ER1A R.A. Eramzhyan, B.S. Ishkhanov, I.M. Kapitonov and V.G. Neudatchin, Phys. Rept. 136 (1986) 229
- 1986FA11 M. Fatemian, R.A. Baldock and D.M. Brink, J. Phys. G12 (1986) L251
- 1986FA13 L.R. Fawcett, Jr., Radiat. Eff. 96 (1986) 239
- 1986FI07 G.F. Filippov, V.S. Vasilevsky, S.P. Kruchinin and L.L. Chopovsky, Yad. Fiz. 43 (1986) 843; Sov. J. Nucl. Phys. 43 (1986) 536
- 1986FI15 B.W. Filippone, Ann. Rev. Nucl. Part. Sci. 36 (1986) 717
- 1986FI1C B.W. Filippone and M. Wahlgren, Nucl. Instrum. Meth. Phys. Res. A243 (1986) 41
- 1986FI1D D. Fick, J. Phys. Soc. Jpn. Suppl. 55 (1986) 423
- 1986FR03 P. Frobrich and G. Grawert, Nucl. Phys. A451 (1986) 338
- 1986FR12 V. Franco and Y. Yin, Phys. Rev. C34 (1986) 608
- 1986GA1H A. Gal, AIP Conf. Proc. 150 (1986) 127
- 1986GA33 A. Gal, Nucl. Phys. A450 (1986) 23c
- 1986GI10 A. Gillibert, L. Bianchi, A. Cunsolo, B. Fernandez, A. Foti, J. Gastebois, Ch. Gregoire, W. Mittig, A. Peghaire, Y. Schutz et al., Phys. Lett. B176 (1986) 317
- 1986GL1A Glaudemans, AIP Conf. Proc. 142 (1986) 316
- 1986GL1E Glukhov et al., in Kharkov (1986) 377, 378
- 1986GLZU Yu.A. Glukhov, E.I. Koshchy, N.S. Lutsay, Yu.G. Mashkarov, E.Yu. Nikolsky, A.T. Rudchik, S.B. Sakuta and K.F. Ustimenkov, in Kharkov (1986) 371
- 1986GLZV Yu.A. Glukhov, E.I. Koshchy, Yu.G. Mashkarov, E.Yu. Nikolsky, A.T. Rudchik, S.B. Sakuta and K.F. Ustimenkov, in Kharkov (1986) 370
- 1986GO1B Gorionov et al., in Kharkov (1986) 373
- 1986GO1F Goldring, J. Phys. Soc. Jpn. Suppl. 55 (1986) 498
- 1986GO1H Gorionov et al., in Kharkov (1986) 374
- 1986GO1K Y. Gohar, Radiat. Eff. 92 (1986) 15
- 1986GO1M B.I. Goryachev, Sov. J. Nucl. Phys. 44 (1986) 252
- 1986GR04 K. Grotz, H.V. Klapdor and J. Metzinger, Phys. Rev. C33 (1986) 1263

- 1986GR1A C. Gregoire and B. Tamain, *Ann. Phys. (France)* 11 (1986) 323
- 1986GR1F J.A. Grundl, in *Sante Fe* (1985) 471
- 1986HA1B B.G. Harvey, *J. Phys. Colloq. (Paris)* 47 (1986) C4-29
- 1986HA1I W.C. Haxton, *AIP Conf. Proc.* 150 (1986) 738
- 1986HA1Q Haxton, *Proc. Int. Nucl. Phys. Conf., Harrogate, U.K., No. 68, Vol. 2* (1986) 415
- 1986HA1T Harmon and Knox, *Bull. Amer. Phys. Soc.* 31 (1986) 1285
- 1986HA27 H.J. Hauser, M. Walz, F. Weng, G. Staudt and P.K. Rath, *Nucl. Phys. A456* (1986) 253
- 1986HA45 G.M. Hale, *Radiat. Eff.* 95 (1986) 97
- 1986HAZR L.F. Hansen, J. Rapaport, X. Wang and F.A. Barrios, *Bull. Amer. Phys. Soc.* 31 (1986) 1237, ED3
- 1986HU1B E.V. Hungerford, *Nucl. Phys. A450* (1986) 157c
- 1986HU1D C.A. Hughes, S.D. Bloom and G.J. Mathews, *Astrophys. J.* 311 (1986) 485
- 1986IM1A Imambekov and Uzikov, in *Kharkov* (1986) 410
- 1986JA02 L. Jarczyk, B. Kamys, Z. Rudy, A. Strzalkowski, B. Styczen, G.P.A. Berg, A. Magiera, J. Meissburger, W. Oelert, P. Von Rossen et al., *Nucl. Phys. A448* (1986) 1
- 1986JA03 L. Jarczyk, B. Kamys, Z. Rudy, A. Strzalkowski, B. Styczen, G.P.A. Berg, A. Magiera, J. Meissburger, W. Oelert, P. von Rossen et al., *Phys. Rev. C33* (1986) 934
- 1986JA15 L. Jarczyk, B. Kamys, Z. Rudy, A. Strzalkowski, B. Styczen, G.P.A. Berg, A. Magiera, J. Meissburger, W. Oelert, P. von Rossen et al., *Z. Phys. A325* (1986) 303
- 1986JO1A R.C. Johnson, *J. Phys. Soc. Jpn. Suppl.* 55 (1986) 7
- 1986KA1B M. Kamimura, M. Yahiro, Y. Iseri, Y. Sakuragi, H. Kameyama and M. Kawai, *Prog. Theor. Phys. Suppl.* 89 (1986) 1
- 1986KA1C M. Kamimura, Y. Sakuragi, M. Yahiro and M. Tanifuji, *J. Phys. Soc. Jpn. Suppl.* 55 (1986) 205
- 1986KA1G O. Karban, *J. Phys. Soc. Jpn. Suppl.* 55 (1986) 774
- 1986KA1J M. Kaur, *Can. J. Phys.* 64 (1986) 338
- 1986KA26 K. Kadija and G. Paic, *Phys. Rev. C34* (1986) 380
- 1986KA30 T. Kaneko, M. Shirata, H. Kanada and Y.C. Tang, *Phys. Rev. C34* (1986) 771
- 1986KA45 T. Kajino, *Nucl. Phys. A460* (1986) 559
- 1986KI1G D.S. Kim, W. Kim, Y.H. Kang, B.N. Sung and J.C. Kim, *New Phys. (South Korea)* 26 (1986) 442
- 1986KL1B Klein and Mutsgers, *Bull. Amer. Phys. Soc.* 31 (1986) 1308

- 1986KN06 D.W. Kneff, B.M. Oliver, E. Goldberg and R.C. Haight, Nucl. Sci. Eng. 94 (1986) 136
- 1986KO19 P.J.J. Kok, J.B.M. de Haas, K. Abrahams, H. Postma and W.J. Huiskamp, Z. Phys. A324 (1986) 271
- 1986KO1E H. Koch, AIP Conf. Proc. 150 (1986) 490
- 1986KO1L S. Kossionides, P. Egelhof, H. Gemmeke, I. Koenig, K.-H. Mobius, E. Steffens and D. Fick, J. Phys. Soc. Jpn. Suppl. 55 (1986) 778
- 1986KO1U Kostin and Trubnikov, in Kharkov (1986) 422, 423
- 1986KR12 A.T. Kruppa, R.G. Lovas, R. Beck and F. Dickmann, Phys. Lett. B179 (1986) 317
- 1986KR1C D. Kramer, K. Becker, K. Blatt, R. Butsch, D. Fick, B. Heck, H. Jansch, H. Leucker, W. Luck, K.-H. Mobius et al., J. Phys. Soc. Jpn. Suppl. 55 (1986) 1080
- 1986LA22 K. Langanke, Nucl. Phys. A457 (1986) 351
- 1986LI04 Q.K.K. Liu, H. Kanada and Y.C. Tang, Phys. Rev. C33 (1986) 1561
- 1986LI15 H. Liskien, Radiat. Eff. 95 (1986) 271
- 1986LI1J H.H. Lin, L.W. Li and E. Norbeck, Nucl. Instrum. Meth. Phys. Res. B17 (1986) 91
- 1986MA16 C.J. Martoff, D. Pocanic, L.W. Whitlow, S.S. Hanna, H. Ullrich, S. Cierjacks, M. Furic, T. Petkovic and H.J. Weyer, Czech. J. Phys. B36 (1986) 378
- 1986MA19 J.F. Mateja, A.D. Frawley, L.C. Dennis and K. Sartor, Phys. Rev. C33 (1986) 1649
- 1986MA1C L. Majling, J. Zofka, V.N. Fetisov and R.A. Eramzhyan, Nucl. Phys. A450 (1986) 189c
- 1986MA1R H. Maekawa, M. Nakagawa, Y. Ikeda, Y. Oyama, S. Yamaguchi, K. Tsuda, T. Fukumoto, A. Hasegawa, T. Mori, K. Kosako et al., in Santa Fe (1985) 101
- 1986MA1S G.S. Masson, T. Wise, P.A. Quin and W. Haeberli, Nucl. Instrum. Meth. Phys. Res. A242 (1986) 196
- 1986MA1U R.A. Matzner, Publ. Astron. Soc. Pac. 98 (1986) 1049
- 1986MC09 M.W. McNaughton, H. Spinka and H. Shimizu, Nucl. Instrum. Meth. Phys. Res. A243 (1986) 137
- 1986MC1D McNally and Nering, Bull. Amer. Phys. Soc. 31 (1986) 891
- 1986ME06 M.C. Mermaz, T. Suomijarvi, R. Lucas, B. Berthier, J. Matuszek, J.P. Coffin, G. Guillaume, B. Heusch, F. Jundt and F. Rami, Nucl. Phys. A456 (1986) 186
- 1986ME13 T. Mertelmeier and H.M. Hofmann, Nucl. Phys. A459 (1986) 387
- 1986ME1F D.F. Measday, Czech. J. Phys. 36 (1986) 395
- 1986MI11 D. Miljanic, S. Blagus and M. Zadro, Phys. Rev. C33 (1986) 2204
- 1986MI1G M. Mizumoto, Proc. 1985 Seminar on Nucl. Data; JAERI-M-86-080 (1986) 124

- 1986MO13 D.J. Morrissey, C. Bloch, W. Benenson, E. Kashy, R.A. Blue, R.M. Ronningen and R. Aryaeinejad, Phys. Rev. C34 (1986) 761
- 1986MO1E Z. Moroz, J. Phys. Soc. Jpn. Suppl. 55 (1986) 221
- 1986MO1J A.M. Mosienko, U. Gensch, T. Naumann, C. Speiring, L. Diosi, T. Gemesy, L. Jenik, J. Krasnovsky, Gy. Pinter, I. Wagner et al., Z. Phys. C30 (1986) 559
- 1986NAZV S. Nakayama, T. Yamagata, M. Tanaka, K. Yuasa, T. Itahashi and H. Ogata, in Harrogate (1986) 138
- 1986NO1C Y. Nojiri, K. Takeyama, K. Matsuta, K. Asahi and T. Minamisono, J. Phys. Soc. Jpn. Suppl. 55 (1986) 391
- 1986PA12 S.B. Patangi and G. Ramachandran, Pramana 26 (1986) 337
- 1986PA1H Pagel, Phil. Trans. Roy. Soc. London A320 (1986) 557
- 1986PAZN Yu.N. Pavlenko, Yu.O. Vasilev, A.S. Gass, V.A. Kiva, V.I. Medvedev, V.M. Pugach, V.A. Usik and A.M. Shidlyk, in Kharkov (1986) 320
- 1986PE05 J.P. Perroud, A. Perrenoud, J.C. Alder, B. Gabioud, C. Joseph, J.F. Loude, N. Morel, M.T. Tran, E. Winkelmann, H. Von Fellenberg et al., Nucl. Phys. A453 (1986) 542
- 1986PE1K S. Pelloni and E.T. Cheng, in Santa Fe (1985) 113
- 1986PF1A H.G. Pfitzner, A.L. Li, K. Murphy, C.R. Howell, M.L. Roberts, I. Slaus, R.L. Walter, M. Herman and H.M. Hofmann, J. Phys. Soc. Jpn. Suppl. 55 (1986) 556
- 1986PO1F Powell, Maglich and Neric, Bull. Amer. Phys. Soc. 31 (1986) 891
- 1986PR01 M. Prakash, P. Braun-Munzinger and J. Stachel, Phys. Rev. C33 (1986) 937
- 1986RA15 Md.A. Rahman and H.M. Sen Gupta, Nuovo Cim. A93 (1986) 236
- 1986RA1D J. Raisanen and R. Lappalainen, Nucl. Instrum. Meth. Phys. Res. B15 (1986) 546
- 1986RA21 J. Rapaport, in Santa Fe (1986) 1229; Radiat. Eff. 95 (1986) 223
- 1986RE13 B.A. Remington, G. Caskey, A. Galonsky, C.K. Gelbke, L. Heilbronn, J. Heltsley, M.B. Tsang, F. Deak, A. Kiss, Z. Seres et al., Phys. Rev. C34 (1986) 1685
- 1986RE1C R. Rebolo, L. Crivellari, F. Castelli, B. Foing and J.E. Beckman, Astron. Astrophys. 166 (1986) 195
- 1986RI01 R. Rieder, P.D. Barnes, B. Bassalleck, R.A. Eisenstein, G. Franklin, R. Grace, C. Maher, P. Pile, J. Szymanski, W.R. Wharton et al., Phys. Rev. C33 (1986) 614
- 1986RO03 R. Rockmore and B. Saghai, Phys. Rev. C33 (1986) 576
- 1986RO1N S.P. Rosen and J.M. Gelb, in Harrogate (1986) F2
- 1986RO1P R.G.H. Robertson, AIP Conf. Proc. 150 (1986) 115
- 1986SA15 Y. Sakuragi, M. Kamimura, M. Yahiro and M. Tanifuji, Phys. Lett. B175 (1986) 105
- 1986SA1D Y. Sakuragi, M. Yahiro and M. Kamimura, Prog. Theor. Phys. Suppl. 89 (1986) 136

- 1986SA1G K.E. Sale and G.J. Mathews, Bull. Amer. Phys. Soc. 31 (1986) 780
- 1986SA1H M.E. Sawan and E.T. Cheng, in Santa Fe (1986) 167
- 1986SA1M J.A. Sawicki, J. Nucl. Mater. A141-143 (1986) 327
- 1986SA1N Y. Sakuragi, Rept. Joint Seminar on Heavy-Ion Nucl. Phys. Nucl. Chem. in the Energy Region of Tandem Accelerators (II), Apr. 1986, Tokai, Ibaraki, Japan (1986) 70
- 1986SA1P K.E. Sale, T.R. Donoghue, A. Abduljalil, J. Cummings, C. Rolfs, P. Schmalbrock, R.G. Seyler, T. Clegg, E.J. Ludwig, R. Fauber et al., J. Phys. Soc. Jpn. Suppl. 55 (1986) 992
- 1986SA1Q H. Sakai, N. Matsuoka, T. Saito and A. Shimizu, J. Phys. Soc. Jpn. Suppl. 55 (1986) 1112
- 1986SA1R H. Sano, T. Kojima, J. Akashi, T. Sato and M. Katada, Hyperfine Interactions 29 (1986) 1259
- 1986SA30 H. Sato and Y. Okuhara, Phys. Rev. C34 (1986) 2171
- 1986SAZL Y. Sakuragi, in Harrogate (1986) 273
- 1986SC28 C.J.S. Scholz, L. Ricken and E. Kuhlmann, Z. Phys. A325 (1986) 203
- 1986SC35 R.L. Schulte, J.M. Papazian and P.N. Adler, Nucl. Instrum. Meth. Phys. Res. B15 (1986) 550
- 1986SE1D H. Sekimoto, K. Oishi, K. Hojo, T. Hojo, D.W. Lee, S. Yukinori, N. Yamamuro, T. Hyodo and J. Yamamoto, in Santa Fe (1985) 107
- 1986SH1F W.Q. Shen, S.Z. Yin, Z.Y. Guo, W.L. Zhan, Y.T. Zhu, G.M. Jin, W.M. Qiao, E.C. Wu and C.L. Jiang, Chin. Phys. 6 (1986) 80
- 1986SH1G Yu.A. Shchekinov and B.V. Vainer, Astrophys. Space Sci. 123 (1986) 103
- 1986SH1L K. Shoda, O. Sasaki, S. Toyama, H. Tsubota, T. Kobayashi and A. Kagaya, Proc. Int. Symp. Weak and Electromag. Interactions in Nuclei, 1-5 July 1986, Heidelberg, West Germany (1986) 352
- 1986SH1P Shostak et al., in Kharkov (1986) 395
- 1986SHZO A.C. Shotter, V. Rapp, T. Davinson and D. Branford, in Harrogate (1986) C217, 404
- 1986SHZP T. Shimoda, N. Ikeda, A. Nakamura, S. Shimoura, K. Katori, T. Fukuda and H. Ogata, in Harrogate (1986) C159, 346
- 1986SI18 S.A. Siddiqui, N. Dytlewski and H.H. Thies, Nucl. Phys. A458 (1986) 387
- 1986SIZS P.J. Simmonds, N.M. Clarke, K.I. Pearce, R.J. Griffiths, C.A. Ogilvie and M. Mannon, in Harrogate (1986) C128, 315
- 1986SO10 L.G. Sobotka, D.G. Sarantites, H. Puchta, F.A. Dilmanian, M. Jaaskelainen, M.L. Halbert, J.H. Barker, J.R. Beene, R.L. Ferguson, D.C. Hensley et al., Phys. Rev. C34 (1986) 917

- 1986SP1A F. Spite and M. Spite, *Astron. Astrophys.* 163 (1986) 140
- 1986ST1E E. Steffens, *J. Phys. Soc. Jpn. Suppl.* 55 (1986) 459
- 1986SU1J H. Sugai, K. Kushita and M. Tanase, *J. Nucl. Mater.* 139 (1986) 248
- 1986SY1A T.J.M. Symons, *Nucl. Phys.* A447 (1986) 157c
- 1986TA1E T.N. Taddeucci, *J. Phys. Soc. Jpn. Suppl.* 55 (1986) 156
- 1986TA1F M. Tanifuji and M. Kamimura, *J. Phys. Soc. Jpn. Suppl.* 55 (1986) 694
- 1986TA1G M. Tanifuji, M. Kamimura and Y. Sakuragi, *J. Phys. Soc. Jpn. Suppl.* 55 (1986) 198
- 1986TA1H A. Takahashi, in *Santa Fe* (1986) 59
- 1986TA1M B. Tamain, *Proc. Int. Nucl. Phys. Conf., Harrogate, U.K., No. 68, Vol. 2* (1986) 247
- 1986TU01 G. Tungate, D. Kramer, R. Butsch, O. Karban, K.H. Mobius, W. Ott, P. Paul, A. Weller, E. Steffens, K. Becker et al., *J. Phys.* G12 (1986) 1001
- 1986TU02 M. Turk, B. Eman and B. Antolkovic, *Fizika (Zagreb)* 18 (1986) 179
- 1986TU1A I. Turkiewicz, K. Becker, K. Blatt, R. Butsch, D. Fick, G. Grawert, B. Heck, H. Jansch, O. Karban, D. Kramer et al., *J. Phys. Soc. Jpn. Suppl.* 55 (1986) 776
- 1986VA13 V.S. Vasilevsky, G.F. Fillipov, L.L. Chopovsky and S.P. Kruchinin, *Izv. Akad. Nauk SSSR Ser. Fiz.* 50 (1986) 151; *Bull. Acad. Sci. USSR Phys. Ser.* 50 (1986) 148
- 1986VE1A Verlarde et al., in *Santa Fe* (1986) 195
- 1986VO20 Yu.M. Volkov, G.A. Kolomensky, E.F. Lakovichev, E.D. Makhnovsky, V.V. Popov, V.P. Fominenko and V.P. Chizhov, *Yad. Fiz.* 44 (1986) 1153; *Sov. J. Nucl. Phys.* 44 (1986) 747
- 1986WA11 R.E. Warner, B.A. Vaughan, D.L. Friesel, P. Schwandt, J.-Q. Yang, G. Caskey, A. Galonsky, B. Remington and A. Nadasen, *Nucl. Phys.* A453 (1986) 605
- 1986WA1H D.-Y. Wang, G.-M. Jin, L. Zhang, H.-K. Yue and X.-M. Wang, *Phys. Energ. Fortis Phys. Nucl.* 10 (1986) 68
- 1986WAZY D. Wang and J. Rapaport, *Bull. Amer. Phys. Soc.* 31 (1986) 853, HH1
- 1986WE1C G.D. Westfall, *Nucl. Phys.* A447 (1986) 591c
- 1986WH01 W.R. Wharton, P.D. Barnes, B. Bassalleck, R.A. Eisenstein, G. Franklin, R. Grace, C. Maher, P. Pile, R. Rieder, J. Szymanski et al., *Phys. Rev.* C33 (1986) 1435
- 1986WI1B D.R. Winn, *IEEE Trans. Nucl. Sci.* 33 (1986) 213
- 1986WI1D D.T. Wilkinson, *Science* 232 (1986) 1517
- 1986XU02 H.M. Xu, D.J. Fields, W.G. Lynch, M.B. Tsang, C.K. Gelbke, M.R. Maier, D.J. Morrissey, J. Pochodzalla, D.G. Sarantites, L.G. Sobotka et al., *Phys. Lett.* B182 (1986) 155
- 1986XU1B H.M. Xu and W.G. Lynch, *Int. Conf. on Nucl. Radiochem, 1-5 Sept. 1986, Beijing, China* (1986) 54

- 1986YA14 A.M. Yasnogorodsky, S.B. Kumshaev, V.V. Ostashko, V.N. Urin and A.N. Nenakhov, *Yad. Fiz.* 44 (1986) 867; *Sov. J. Nucl. Phys.* 44 (1986) 558
- 1986YA1F Y. Yamamoto, *Prog. Theor. Phys.* 75 (1986) 639
- 1986YA1L Yamagata et al., in *Harrogate* (1986) B63
- 1986YA1M A.M. Yasnogorodsky, V.V. Ostashko, V.N. Urin and A.N. Nenakhov, *J. Phys. Soc. Jpn. Suppl.* 55 (1986) 892
- 1986YO06 H. Yokota, K. Nakayama, K. Ichimaru, T. Katsumi, T. Mori, S. Igarashi, K. Hama, R. Chiba, K. Nakai, J. Chiba et al., *Phys. Rev. Lett.* 57 (1986) 807
- 1986YO1A M.I. Yousef, *J. Phys. Soc. Jpn. Suppl.* 55 (1986) 766
- 1986YOZU J. Yorkston, A.C. Shotter, T. Davinson, D. Branford and E.W. Macdonald, in *Harrogate* (1986) C216, 403
- 1986ZA1C Zaritskii et al., in *Kharkov* (1986) 401
- 1986ZE01 N.S. Zelenskaya and A.K. Morzabaev, *Yad. Fiz.* 43 (1986) 879; *Sov. J. Nucl. Phys.* 43 (1986) 559
- 1986ZO1A J. Zofka, *Nucl. Phys.* A450 (1986) 165c
- 1987AJ1A F. Ajzenberg-Selove, in *Dubna* (1987) 341
- 1987AK1A Akhverdyan et al., in *Panic* (1987) 708
- 1987AL10 D.V. Aleksandrov, Yu.A. Glukhov, E.Yu. Nikolsky, B.G. Novatsky, A.A. Ogloblin and D.N. Stepanov, *Yad. Fiz.* 45 (1987) 1217; *Sov. J. Nucl. Phys.* 45 (1987)
- 1987AR13 A.E. Aravantinos and A.C. Xenoulis, *Phys. Rev.* C35 (1987) 1746
- 1987AR1C Arnould, *Phil. Trans. Roy. Soc. (London)* 323 (1987) 251
- 1987AR1E Arima, *Proc. Beijing Int. Symp. on Phys. at Tandem 1986* (1987) 3
- 1987AR1J K. Arai, M. Hasimoto and T. Fukui, *Astron. Astrophys.* 179 (1987) 17
- 1987AS05 H.J. Assenbaum, K. Langanke and C. Rolfs, *Z. Phys.* A327 (1987) 461
- 1987AU04 S.M. Austin, N. Anantaraman and J.S. Winfield, *Can. J. Phys.* 65 (1987) 609
- 1987AU1C Auchev et al., in *Yurmala* (1987) 395
- 1987AU1E J. Audouze, *J. Astrophys. Astron.* 8 (1987) 81
- 1987BA13 J. Banaigs, J. Berger, P. Berthet, G. Bizard, M. Boivin, M. De Sanctis, J. Duflo, F.L. Fabbri, R. Frascaria, L. Goldzahl et al., *Phys. Rev.* C35 (1987) 1416
- 1987BA1I B.F. Bayman and Y.C. Tang, *Phys. Rept.* 147 (1987) 155
- 1987BA2F Baer et al., in *Panic* (1987) 352
- 1987BA38 G.J. Balster, P.C.N. Crouzen, P.B. Goldhoorn, R.H. Siemssen and H.W. Wilschut, *Nucl. Phys.* A468 (1987) 93
- 1987BA89 J.N. Bahcall, *Rev. Mod. Phys.* 59 (1987) 505

- 1987BE1K Begnhanov et al., in Yurmala (1987) 53
- 1987BE58 B. Berthier, R. Boisgard, J. Julien, J.M. Hisleur, R. Lucas, C. Mazur, C. Ngo, M. Ribrag and C. Cerruti, Phys. Lett. B193 (1987) 417
- 1987BEYI A.V. Belozyorov, C. Borcea, Z. Dlouhy, A.M. Kalinin, Nguyen Hoai Chau and Yu.E. Penionzhkevich, JINR-E15-87-733 (1987)
- 1987BL13 C. Bloch, W. Bensenon, A.I. Galonsky, E. Kashy, J. Heltsley, L. Heilbronn, M. Lowe, B. Remington, D.J. Morrissey and J. Kasagi, Phys. Rev. C36 (1987) 203
- 1987BO40 C. Borcea, A.V. Belozyorov, Z. Dlouhy, A.M. Kalinin, Nguyen Hoai Chau and Yu.E. Penionzhkevich, Rev. Roum. Phys. 32 (1987) 497
- 1987BR32 F.P. Brady, Can. J. Phys. 65 (1987) 578
- 1987BU04 N.A. Burkova and M.A. Zhusupov, Izv. Akad. Nauk SSSR Ser. Fiz. 51 (1987) 182; Bull. Acad. Sci. USSR Phys. Ser. 51 (1987) 167
- 1987BU18 S. Burzynski, K. Czerski, A. Marcinkowski and P. Zupranski, Nucl. Phys. A473 (1987) 179
- 1987BU27 N.T. Burtebaev, A.D. Duisebaev, V.S. Sadkovskii and G.A. Feofilov, Izv. Akad. Nauk SSSR Ser. Fiz. 51 (1987) 615; Bull. Acad. Sci. USSR Phys. Ser. 51 (1987) 191
- 1987CH1D Chrien et al., Bull. Amer. Phys. Soc. 32 (1987) 1560
- 1987CH26 Z. Chen, C.K. Gelbke, J. Pochodzalla, C.B. Chitwood, D.J. Fields, W.G. Gong, W.G. Lynch and M.B. Tsang, Nucl. Phys. A473 (1987) 564
- 1987CO02 J. Cook, A.K. Abdallah, M.N. Stephens and K.W. Kemper, Phys. Rev. C35 (1987) 126
- 1987CO16 J. Cook, M.N. Stephens and K.W. Kemper, Nucl. Phys. A466 (1987) 168
- 1987CO1X A.A. Coley, Astrophys. Space Sci. 138 (1987) 393
- 1987COZZ J. Cook and K.W. Kemper, Bull. Amer. Phys. Soc. 32 (1987) 1542, AB6
- 1987DE14 E. Dekempeneer, H. Liskien, L. Mewissen and F. Poortmans, Nucl. Instrum. Meth. Phys. Res. A256 (1987) 489
- 1987DE37 F. Deak, A. Kiss, Z. Seres, G. Caskey, A. Galonsky and B. Remington, Nucl. Instrum. Meth. Phys. Res. A258 (1987) 67
- 1987DE43 H. De Vries, C.W. De Jager and C. De Vries, At. Data Nucl. Data Tables 36 (1987) 495
- 1987DM1C Dmitrenko et al., in Yurmala (1987) 330
- 1987DO02 A. d'Onofrio, B. Delaunay, J. Delaunay, H. Dumont, J. Gomez del Campo, A. Brondi, R. Moro, M. Romano, F. Terrasi and J.F. Bruandet, Z. Phys. A326 (1987) 335
- 1987DO1H R. Dominguez-Tenreird and G. Yepes, Astron. Astrophys. 177 (1987) 5
- 1987DR1A Drukarev and Strikman, in Yurmala (1987) 228

- 1987DU07 J. Dufflo, Phys. Rev. C36 (1987) 1425
- 1987DU1C D.K. Duncan and L.M. Hobbs, J. Astrophys. Astron. 8 (1987) 83
- 1987FA02 A. Fahli, J.P. Coffin, G. Guillaume, B. Heusch, F. Jundt, F. Rami, P. Wagner, P. Fintz, A.J. Cole, S. Kox et al., Z. Phys. A326 (1987) 169
- 1987FE1A E.-P. Feng, Q. Wang, Y.-T. Zhu, X. Yin, H.-B. Miao, S.-M. Sun, S.-L. Li, Z.-L. Wu, G.-Y. Fan, Y.-X. Xie et al., Chin. Phys. 7 (1987) 121
- 1987FI1C E.L. Fireman, A.E. Litherland and J.K. Rowley, Nucl. Instrum. Meth. Phys. Res. B29 (1987) 387
- 1987FI1D D. Fick, Phys. Bl. (West Germany) 43 (1987) 446
- 1987FL1A Flerov, in Dubna (1987) 9
- 1987FO08 D. Fox, D.A. Cebra, J. Karn, C. Parks, G.D. Westfall and W.K. Wilson, Phys. Rev. C36 (1987) 640
- 1987FO1B W.A. Fowler, Quart. J. Roy. Astron. Soc. 28 (1987) 87
- 1987FR1C G. Friedlander and J. Weneser, Science 235 (1987) 760
- 1987GAZM S.A. Gaidenko, E.P. Kadkin, M.V. Pasechnik, L.S. Saltykov and A.D. Fursa, in Yurmala (1987) 299
- 1987GE1B C.-K. Gelbke and D.H. Boal, Prog. Part. Nucl. Phys. 19 (1987) 33
- 1987GL05 Yu.A. Glukhov, A.S. Demyanova, A.A. Ogloblin and S.B. Sakuta, Yad. Fiz. 45 (1987) 1236; Sov. J. Nucl. Phys. 45 (1987) 767
- 1987GO17 P.L. Gonthier, B. Bouma, P. Harper, R. Ramaker, D.A. Cebra, Z.M. Koenig, D. Fox and G.D. Westfall, Phys. Rev. C35 (1987) 1946
- 1987GO1V C.D. Goodman, Can. J. Phys. 65 (1987) 549
- 1987GOZF O.K. Gorpinich, E.P. Kadkin, S.N. Kondratev, L.S. Saltykov, V.D. Sklyarenko and V.V. Tokarevsky, in Yurmala (1987) 341
- 1987GOZN M.G. Gornov, P.V. Morokhov, V.A. Pechkurov, F.M. Sergeev, A.A. Khomutov and R.R. Shafigullin, in Yurmala (1987) 269
- 1987GR11 R.E.L. Green, R.G. Korteling, J.M. D'Auria, K.P. Jackson and R.L. Helmer, Phys. Rev. C35 (1987) 1341
- 1987GR1I A.M. Green and J.A. Niskanen, Prog. Part. Nucl. Phys. 18 (1987) 93
- 1987HA30 P.G. Hansen and B. Jonson, Europhys. Lett. 4 (1987) 409
- 1987HA45 D. Hahn and H. Stocker, Phys. Rev. C35 (1987) 1311
- 1987HE1H T.K. Hemmick, D. Elmore, P.W. Kubik, S.L. Olsen, T. Gentile, D. Nitz, D. Ciampa, H. Kagan, P. Haas, P.F. Smith et al., Nucl. Instrum. Meth. Phys. Res. B29 (1987) 389

- 1987HE24 R.S. Henderson, W.P. Alford, D. Frekers, O. Hausser, R.L. Helmer, K.H. Hicks, K.P. Jackson, C.A. Miller, M.C. Vetterli and S. Yen, Nucl. Instrum. Meth. Phys. Res. A257 (1987) 97
- 1987HNZZ V. Hnizdo and K.W. Kemper, Bull. Amer. Phys. Soc. 32 (1987) 1566, DB1
- 1987HO1M L.M. Hobbs and D.K. Duncan, Astrophys. J. 317 (1987) 796
- 1987IM04 O. Imambekov and Yu.N. Uzikov, Izv. Akad. Nauk SSSR Ser. Fiz. 51 (1987) 947; Bull. Acad. Sci. USSR Phys. Ser. 51 (1987) 107
- 1987IM1F Imambekov, Uzikov and Zhusupov, in Panic (1987) 276
- 1987IR01 F. Irom, H.W. Baer, A.G. Bergmann, J.D. Bowman, P. Heusi, D.H. Fitzgerald, C.J. Seftor, M.E. Sadler, J.N. Knudson, W.J. Briscoe et al., Phys. Rev. C36 (1987) 1453
- 1987JA06 B.V. Jacak, G.D. Westfall, G.M. Crawley, D. Fox, C.K. Gelbke, L.H. Harwood, B.E. Hasselquist, W.G. Lynch, D.K. Scott, H. Stocker et al., Phys. Rev. C35 (1987) 1751
- 1987KA09 T. Kajino, H. Toki and K.-I. Kubo, Phys. Rev. C35 (1987) 1370
- 1987KA17 K. Kadija, G. Paic, B. Antolkovic, D. Ferenc, A. Djaloeis and J. Bojowald, Phys. Rev. C36 (1987) 425
- 1987KA1I M. Kamimura, Y. Sakuragi, Y. Iseri, M. Yahiro, H. Kameyama, M. Kawai and M. Tanifuji, INS-REP.-606 (1987)
- 1987KA1R T. Kajino, H. Toki and S.M. Austin, Astrophys. J. 319 (1987) 531
- 1987KA1U Kajino, Toki, Kubo and Tanihata, MSUCL-614 (1987)
- 1987KA1V Kajino, MSUCL-618 (1987)
- 1987KA22 T. Kaneko, M. Shirata, H. Kanada and Y.C. Tang, Phys. Lett. B192 (1987) 259
- 1987KA25 K. Kadija, G. Paic, D. Vranic, A. Berdoz, F. Foroughi, Ch. Nussbaum, H.H. Muller, P. Schober and St. Steiner, Nucl. Phys. A469 (1987) 183
- 1987KI05 A. Kiss, F. Deak, Z. Seres, G. Caskey, A. Galonsky, L. Heilbronn, B.A. Remington and J. Kasagi, Phys. Lett. B184 (1987) 149
- 1987KI1C H.R. Kissener, I. Rotter and N.G. Goncharova, Fortschr. Phys. 35 (1987) 277
- 1987KIZY A. Kiss, F. Deak, Z. Seres, G. Caskey, A. Galonsky, B. Remington, C.K. Gelbke, M.B. Tsang and J.J. Kolata, Bull. Amer. Phys. Soc. 32 (1987) 1551, BB11
- 1987KN04 H.D. Knox, D.A. Resler and R.O. Lane, Nucl. Phys. A466 (1987) 245
- 1987KN09 V.A. Knyr, A.I. Mazur and Yu.F. Smirnov, Ukr. Fiz. Zh. 32 (1987) 1129
- 1987KO15 T. Kozik, J. Buschmann, K. Grotowski, H.J. Gils, N. Heide, J. Kiener, H. Klewe-Nebenius, H. Rebel, S. Zagromski, A.J. Cole et al., Z. Phys. A326 (1987) 421
- 1987KO1L Kozmyr and Sokolov, in Yurmala (1987) 331
- 1987KO43 E.A. Kotikov and E.D. Makhnovsky, Yad. Fiz. 46 (1987) 1009; Sov. J. Nucl. Phys. 46 (1987) 579

- 1987KR10 D. Krofcheck, E. Sugarbaker, A.J. Wagner, J. Rapaport, D. Wang, J.N. Bahcall, R.C. Byrd, C.C. Foster, C.D. Goodman, C. Gaarde et al., Phys. Lett. B189 (1987) 299
- 1987KU23 Y. Kuno, K. Nagamine and T. Yamazaki, Nucl. Phys. A475 (1987) 615
- 1987KW01 E. Kwasniewicz and J. Kisiel, J. Phys. G13 (1987) 121
- 1987KW03 E. Kwasniewicz and J. Kisiel, Rev. Roum. Phys. 32 (1987) 607
- 1987LA1J A. Lamberty, E. Michels and P. De Bievre, Int. J. Mass Spectrom. Ion Proc. 79 (1987) 311
- 1987LE33 F.S. Levin, Nucl. Phys. A463 (1987) 487c
- 1987LI1J Lichtenstadt et al., in Panic (1987) 636
- 1987LU1B Lubovoi and Chitanava, in Yurmala (1987) 512
- 1987LY04 W.G. Lynch, Nucl. Phys. A471 (1987) 309c
- 1987MA1I Matthews et al., in Panic (1987) 360
- 1987MA1X C.J. Martoff, Science 237 (1987) 507
- 1987MA2C Malaney and Fowler, OAP-680, To be published in Origin and Distribution of the Elements (1987)
- 1987MAZC G.J. Mathews, G.M. Fuller and C. Alcock, Bull. Am. Phys. Soc. 32 (1987) 1123, KH 1
- 1987MI34 S. Micek, H. Rebel, H.J. Gils, H. Klewe-Nebenius, S. Zagromski and D.K. Srivastava, Z. Phys. A328 (1987) 467
- 1987MI38 M. Mian, Phys. Rev. C35 (1987) 1463
- 1987MU03 J.A. Muzycka and B.I. Pustyl'nik, Yad. Fiz. 45 (1987) 90; Sov. J. Nucl. Phys. 45 (1987) 57
- 1987MU04 D. Mukhopadhyay, K.-H. Mobius, K. Heck and G. Grawert, Phys. Rev. C35 (1987) 1324
- 1987MU1D Muzitshka, Pustil'nik, and Avdechikov, in Dubna (1987) 589
- 1987NA01 M.N. Namboodiri, R.K. Choudhury, L. Adler, J.D. Bronson, D. Fabris, U. Garg, P.L. Gonthier, K. Hagel, D.R. Haenni, Y.W. Lui et al., Phys. Rev. C35 (1987) 149
- 1987NI04 W. Nitsche, G.J. Wagner, K.T. Knopfle, P. Grabmayr and Y. Kawazoe, Z. Phys. A326 (1987) 435
- 1987OSZZ V.V. Ostashko and A.M. Yasnogorodskii, in Yurmala (1987) 322
- 1987PA12 S.J. Padalino, K. Sartor, L.C. Dennis and K.W. Kemper, Phys. Rev. C35 (1987) 1692
- 1987PA1F R. Pallavicini, M. Cerruti-Sola and D.K. Duncan, Astron. Astrophys. 174 (1987) 116
- 1987PA1G Pasechnik et al., in Yurmala (1987) 268
- 1987PE1C Penionshkevich, in Dubna (1987) 364

- 1987PO03 J. Pochodzalla, C.K. Gelbke, W.G. Lynch, M. Maier, D. Ardouin, H. Delagrange, H. Doubre, C. Gregoire, A. Kyanowski, W. Mittig et al., Phys. Rev. C35 (1987) 1695
- 1987PO05 H. Poth, H. Barth, G. Buche, A.D. Hancock, H. Koch, Th. Kohler, A. Kreissl, U. Raich, D. Rohmann, A. Wolf et al., Nucl. Phys. A466 (1987) 667
- 1987PO1H B. Povh, Prog. Part. Nucl. Phys. 18 (1987) 183
- 1987PO23 J. Pochodzalla, Nucl. Phys. A471 (1987) 289c
- 1987RA1D R. Ramaty and R.J. Murphy, Space Sci. Rev. 45 (1987) 213
- 1987RA32 J. Rapaport, Can. J. Phys. 65 (1987) 574
- 1987RE1F R. Rebolo, J. Beckman and P. Molaro, Astron. Astrophys. 172 (1987) L17
- 1987RI1E J. Rich, D.L. Owen and M. Spiro, Phys. Rept. 151 (1987) 239
- 1987RO25 C. Rolfs, H.P. Trautvetter and W.S. Rodney, Rept. Prog. Phys. 50 (1987) 233
- 1987ROZY S.H. Rokni, H.W. Baer, J.D. Bowman, F. Irom, M.J. Leitch, J. Alster, E. Piasetzky, J.R. Comfort, J.N. Knudson, B.L. Clausen et al., Bull. Amer. Phys. Soc. 32 (1987) 1119, KE9
- 1987SA04 Y. Sakuragi, M. Yahiro, M. Kamimura and M. Tanifuji, Nucl. Phys. A462(1987) 173
- 1987SA1C Sakuragi, Yahiro and Kamimura, INS-REP.-600 (1986)
- 1987SA46 H. Sakai, N. Matsuoka, T. Noro, T. Saito, A. Shimizu, M. Tosaki, M. Ieiri, K. Imai, A. Sakaguchi, Y. Takeuchi et al., Nucl. Instrum. Meth. Phys. Res. A257 (1987) 279
- 1987SC08 D. Schmidt, D. Seeliger, G.N. Lovchikova and A.M. Trufanov, Nucl. Sci. Eng. 96 (1987) 159
- 1987SC18 U. Schroder, A. Redder, C. Rolfs, R.E. Azuma, L. Buchmann, C. Campbell, J.D. King and T.R. Donoghue, Phys. Lett. B142 (1987) 55
- 1987SH23 W. Shen, Y. Zhu, W. Zhan, Z. Guo, S. Yin, W. Qiao and X. Yu, Nucl. Phys. A472 (1987) 358
- 1987SI1C Siemssen, Proc. Beijing Int. Symp. on Phys. at Tandem, 1986 (1987) 317
- 1987SO13 L.G. Sobotka, D.G. Sarantites, Ze Li, E.L. Dines, M.L. Halbert, D.C. Hensley, R.P. Schmitt, Z. Majka, G. Nebbia, H.C. Griffin et al., Nucl. Phys. A471 (1987) 131c
- 1987SO15 L.G. Sobotka, D.G. Sarantites, Ze Li, E.L. Dines, M.L. Halbert, D.C. Hensley, J.C. Lisle, R.P. Schmitt, Z. Majka, G. Nebbia et al., Phys. Rev. C36 (1987) 2713
- 1987SO1C Soundranayagam, Seth and Parker, in Panic (1987) 292
- 1987SP1C F. Spite, M. Spite, R.C. Peterson and F.H. Chaffee, Jr., Astron. Astrophys. 171 (1987) L8
- 1987SP1D F. Spite and M. Spite, J. Astron. Astrophys. 8 (1987) 93
- 1987ST01 G.S.F. Stephans, R.V.F. Janssens, D.G. Kovar and B.D. Wilkins, Phys. Rev. C35 (1987) 614

- 1987SU06 T. Suzuki, D.F. Measday and J.P. Roalsvig, Phys. Rev. C35 (1987) 2212
- 1987SV1A V.A. Sviciulis and R.K. Kalinauskas, Sov. Phys.-Collect. 27 (1987) 10
- 1987TA06 Y.C. Tang, Nucl. Phys. A463 (1987) 377c
- 1987TAZU I. Tanihata, H. Hamagaki, O. Hashimoto, Y. Shida, O. Yamakawa, T. Kobayashi, K. Sugimoto and N. Takahashi, in Panic (1987) 474; LBL-22820 (1987) 82
- 1987TE1D Ter Nersesyants, in Yurmala (1987) 540
- 1987TI05 C.I.W. Tingwell, J.D. King and D.G. Sargood, Aust. J. Phys. 40 (1987) 319
- 1987TO06 M. Tosaki, M. Fujiwara, K. Hosono, T. Noro, H. Ito, T. Yamazaki and H. Ikegami, Nucl. Phys. A463 (1987) 429c
- 1987TR05 W. Trautmann, K.D. Hildenbrand, U. Lynen, W.F.J. Muller, H.J. Rabe, H. Sann, H. Stelzer, R. Trockel, R. Wada, N. Brummund et al., Nucl. Phys. A471 (1987) 191c
- 1987TR1D Trofimenko, Tesevich and Kuzhir, in Yurmala (1987) 219
- 1987VA05 V.V. Varlamov, B.S. Ishkhanov, V.V. Surgutanov, A.P. Chernyaev and R.A. Er-amzhyan, Izv. Akad. Nauk SSSR Ser. Fiz. 51 (1987) 195; Bull. Acad. Sci. USSR Phys. Ser. 51 (1987) 179
- 1987VA29 Yu.O. Vasilev, V.V. Zerkin, V.A. Kiva, V.I. Medvedev, Yu.N. Pavlenko, Dzh. Pizent and V.M. Pugach, Izv. Akad. Nauk SSSR Ser. Fiz. 51 (1987) 983; Bull. Acad. Sci. USSR Phys. Ser. 51 (1987) 140
- 1987VD01 A.I. Vdovin and I.N. Loshchakov, Yad. Fiz. 45 (1987) 67; Sov. J. Nucl. Phys. 45 (1987) 42
- 1987VI14 V.E. Viola, Nucl. Phys. A471 (1987) 53c
- 1987WA09 R. Wada, K.D. Hildenbrand, U. Lynen, W.F.J. Muller, H.J. Rabe, H. Sann, H. Stelzer, W. Trautmann, R. Trockel, N. Brummund et al., Phys. Rev. Lett. 58 (1987) 1829
- 1987WA36 X.-C. Wang, H. Bando and H. Takaki, Z. Phys. A 327 (1987) 59
- 1987WAZT J.W. Watson, W.P. Alford, R. Helmer, C. Zafiratos, R. Abegg, A. Celler, S. El-Kateb, D. Frekers, O. Hausser, R. Henderson et al., Bull. Amer. Phys. Soc. 32 (1987) 1578, EC1
- 1987WE1C J. Weneser and G. Friedlander, Science 235 (1987) 755
- 1987WI09 J.S. Winfield, N. Anantaraman, S.M. Austin, Ziping Chen, A. Galonsky, J. van der Plicht, H.-L. Wu, C.C. Chang and G. Ciangaru, Phys. Rev. C35 (1987) 1734
- 1987YA16 Yu.P. Yakovlev, Yad. Fiz. 46 (1987) 459; Sov. J. Nucl. Phys. 46 (1987) 244
- 1987YA1M Y. Yamamoto, Phys. Rev. C36 (1987) 2166
- 1987ZA01 M. Zadro, S. Blagus, D. Miljanic and D. Rendic, Nucl. Sci. Eng. 95 (1987) 79
- 1987ZH1E Zhao et al., in Panic (1987) 710
- 1988AL1G Aleksandrov et al., in Baku (1988) 377

- 1988AL1H Alizade, in Baku (1988) 418
- 1988AN1J Anantaraman, Austin and Winfield, MSUCL-633 (1988)
- 1988BA1R Barabanov, in Baku (1988) 559
- 1988BA86 J.N. Bahcall and R.K. Ulrich, Rev. Mod. Phys. 60 (1988) 297
- 1988BE09 C.A. Bertulani and G. Baur, Nucl. Phys. A480 (1988) 615
- 1988BEYJ A.V. Belozerov, K. Borcha, I. Vintsour, Z. Dlougy, Nguen Khoai Tyau and Yu.Eh. Penionzhkevich, in Baku (1988) 380
- 1988BL09 C. Bloch, W. Benenson, A.I. Galonsky, E. Kashy, J. Heltsley, L. Heilbronn, M. Lowe, R.J. Radtke, B. Remington, J. Kassagi et al., Phys. Rev. C37 (1988) 2469
- 1988BO05 S. Boffi, C. Giusti and F.D. Pacati, Nucl. Phys. A476 (1988) 617
- 1988BO46 J. Bogdanowicz, Nucl. Phys. A479 (1988) 323c
- 1988BU1Q Buranov et al., in Baku (1988) 363
- 1988BUZH V.V. Buranov, N.I. Venikov, Yu.A. Glukhov, A.M. Dobyichin, A.A. Ogloblin, S.B. Sakuta and V.N. Unezhev, in Baku (1988) 362
- 1988BUZI V.V. Buranov, N.I. Venikov, Yu.A. Glukhov, A.M. Dobyichin, A.A. Ogloblin, S.B. Sakuta and V.N. Unezhev, in Baku (1988) 361
- 1988CA06 G. Caskey, L. Heilbronn, B. Remington, A. Galonsky, F. Deak, A. Kiss and Z. Seres, Phys. Rev. C37 (1988) 696
- 1988CEZZ D.A. Cebra, W. Benenson, Y. Chen, E. Kashy, D.J. Morrissey, A. Pradhan, A. Vandermoden, G.D. Westfall, W.K. Wilson, R.S. Tickle et al., Bull. Amer. Phys. Soc. 33 (1988) 963, DI12
- 1988DI02 S.S. Dietrich and B.L. Berman, At. Data Nucl. Data Tables 38 (1988) 199
- 1988DI1B G.H.F. Diercksen, A.J. Sadlej, D. Sundholm and P. Pyykko, Chem. Phys. Lett. 143 (1988) 163
- 1988DM1A Dmitrenko, Koyzr and Solokov, in Baku (1988) 348
- 1988FIZT G.F. Filippov and L.L. Chopovsky, in Baku (1988) 433
- 1988FO1A W.A. Fowler, Interact. and Struct. in Nuclei, Proc. Conf. to Honor D. Wilkinson FRS, 7-9 Sept. 1987, Brighton, UK (1988) 119
- 1988GIZU Yu.R. Gismatullin, A.A. Melentev, V.I. Ostroumov, A.M. Petukhov and M.A. Stalevich, in Baku (1988) 293
- 1988GO1F Goryonov et al., in Baku (1988) 365
- 1988GO1H Goryonov et al., in Baku (1988) 367
- 1988GR07 G. Grawert, Z. Moroz and G. Tungate, Phys. Lett. B205 (1988) 171
- 1988GU1C Guseninov et al., in Baku (1988) 258

- 1988HA44 R. Hausmann, Nucl. Phys. A479 (1988) 247c
- 1988HE08 R. Henneck, C. Gysin, P. Haffter, M. Hammans, W. Lorenzon, M.A. Pickar, I. Sick and S. Burzynski, Phys. Rev. C37 (1988) 2224
- 1988HI06 M. Hilgemeier, H.W. Becker, C. Rolfs, H.P. Trautvetter and J.W. Hammer, Z. Phys. A329 (1988) 243
- 1988IV1A Ivanov et al., in Baku (1988) 537
- 1988JO1C B. Jonson, S. Mattsson, G. Nyman, O. Tengblad, M.J.G. Borge, P.G. Hansen and K. Riisager, AIP Conf. Proc. 164 (1988) 223
- 1988KA02 T. Kajino, G.F. Bertsch and K. Kubo, Phys. Rev. C37 (1988) 512
- 1988KA07 T. Kajino, H. Toki, K.-I. Kubo and I. Tanihata, Phys. Lett. B202 (1988) 475
- 1988KA09 K. Katori, T. Shimoda, T. Fukuda, S. Shimoura, A. Sakaguchi, M. Tanaka, T. Yamagata, N. Takahashi, H. Ogata, M. Kamimura et al., Nucl. Phys. A480 (1988) 323
- 1988KA1H L. Kawano, D. Schramm and G. Steigman, Astrophys. J. 327 (1988) 750
- 1988KA1L Kademsky, Lukyanovich, Rudchik and Skalnitsky, in Baku (1988) 462
- 1988KAZY T. Kajino, G.J. Mathews and K. Ikeda, Bull. Amer. Phys. Soc. 33 (1988) 1029, GM3
- 1988KI05 J.M. Kidd, P.J. Lindstrom, H.J. Crawford and G. Woods, Phys. Rev. C37 (1988) 2613
- 1988KO1C Kozchy, Mashkarov and Rudchik, in Baku (1988) 350
- 1988KOZL L.P. Korda, B.A. Nemashkalo, G.K. Khomyakov, A.S. Kachan and A.N. Vodin, in Baku (1988) 586
- 1988KW02 E. Kwasniewicz and J. Kisiel, Acta Phys. Pol. B19 (1988) 141
- 1988LA1C A. Lamberty and P. de Bievre, Int. J. Mass Spectrom. Ion Proc. 83 (1988) 135
- 1988LI1A Liu et al., Bull. Amer. Phys. Soc. 33 (1988) 903
- 1988MA07 J.F. Mateja, G.L. Gentry, N.R. Fletcher, L.C. Dennis and A.D. Frawley, Phys. Rev. C37 (1988) 1004
- 1988MA1H Manokhin, INDC(CCP)-283 (1988)
- 1988MEZS B.S. Meyer, G.M. Fuller, G.J. Mathews and C.R. Alcock, Bull. Amer. Phys. Soc. 33 (1988) 988, EM12
- 1988NE1A Nemets, Pavlenko and Pugach, in Baku (1988) 325
- 1988OT01 W. Ott, R. Butsch, H. Jansch, G. Tungate, E. Steffens, K. Becker, K. Blatt, H. Leucker, D. Fick, J. Gomez-Camacho et al., J. Phys. G14 (1988) L7
- 1988PO1F Ponkratenko, Nemets and Rudchik, in Baku (1988) 365
- 1988POZS N.A.F.M. Poppelier, J.H. de Vries, A.A. Wolters and P.W.M. Glaudemans, AIP Conf. Proc. 164 (1988) 334

- 1988PR02 M. Prakash, P. Braun-Munzinger, J. Stachel and N. Alamanos, Phys. Rev. C37 (1988) 1959
- 1988RE1B R. Rebolo, P. Molaro, C. Abia and J.E. Beckman, Astron. Astrophys. 193 (1988) 193
- 1988RO03 S.H. Rokni, H.W. Baer, A.G. Bergmann, J.D. Bowman, F. Irom, M.J. Leitch, C.J. Seftor, J. Alster, E. Piassetzky, B.L. Clausen et al., Phys. Lett. B202 (1988) 35
- 1988RU01 V.A. Rubchenya and S.G. Yavshits, Z. Phys. A329 (1988) 217
- 1988SA10 Y. Sakuragi, M. Yahiro, M. Kamimura and M. Tanifuji, Nucl. Phys. A480 (1988) 361
- 1988SA19 H. Sato, Phys. Rev. C37 (1988) 2902
- 1988SH1E Shvedov, Nemets and Rudchik, in Baku (1988) 351
- 1988SH20 A.C. Shotter and M.A. Nagarajan, J. Phys. G14 (1988) L109
- 1988ST06 J. Stevenson, B.A. Brown, Y. Chen, J. Clayton, E. Kashy, D. Mikolas, J. Nolen, M. Samuel, B. Sherrill, J.S. Winfield et al., Phys. Rev. C37 (1988) 2220
- 1988TA1A I. Tanihata, Nucl. Phys. A478 (1988) 795c
- 1988TA1D Tartakovsky, Fu and Fursaev, in Baku (1988) 489
- 1988TA29 H. Tamura, W. Bruckner, H. Dobbeling, R.S. Hayano, T. Ishikawa, M. Iwasaki, T. Motoki, H. Outa, S. Paul, B. Povh et al., Nucl. Phys. A479 (1988) 161c
- 1988US1A Usmanov, Zhusupov and Ivkina, in Baku (1988) 168
- 1988VA03 A.G.M. van Hees, A.A. Wolters and P.W.M. Glaudemans, Nucl. Phys. A476 (1988) 61
- 1988VA1E Vagner et al., in Baku (1988) 383
- 1988VUZZ V.A. Vukolov and F.E. Chukreev, in Baku (1988) 560
- 1988WO04 A.A. Wolters, A.G.M. van Hees and P.W.M. Glaudemans, Europhys. Lett. 5 (1988) 7
- 1988ZH1B Zhusupov and Usmanov, in Baku (1988) 167
- 1990AJ01 F. Ajzenberg-Selove, Nucl. Phys. A506 (1990) 1

