

# Energy Levels of Light Nuclei $A = 18$

D.R. Tilley <sup>a,b</sup>, H.R. Weller <sup>a,c</sup> and C.M. Cheves <sup>a,c</sup>, R.M. Chasteler <sup>a,c</sup>

<sup>a</sup> *Triangle Universities Nuclear Laboratory, Durham, NC 27708-0308, USA*

<sup>b</sup> *Department of Physics, North Carolina State University, Raleigh, NC 27695-8202, USA*

<sup>c</sup> *Department of Physics, Duke University, Durham, NC 27708-0305, USA*

**Abstract:** An evaluation of  $A = 18$ – $19$  was published in *Nuclear Physics A595* (1995), p. 1. This version of  $A = 18$  differs from the published version in that we have corrected some errors discovered after the article went to press. The introduction and introductory tables have been omitted from this manuscript. [Reference](#) key numbers are in the NNDC/TUNL format.

(References closed October 31, 1994)

This work is supported by the US Department of Energy, Office of High Energy and Nuclear Physics, under: Contract No. DEFG05-88-ER40441 (North Carolina State University); Contract No. DEFG05-91-ER40619 (Duke University).

## Table of Contents for A = 18

Below is a list of links for items found within the PDF document. The introductory [Table 3](#) is available on this website via the link.

A. Nuclides: [<sup>18</sup>He](#), [<sup>18</sup>Li](#), [<sup>18</sup>Be](#), [<sup>18</sup>B](#), [<sup>18</sup>C](#), [<sup>18</sup>N](#), [<sup>18</sup>O](#), [<sup>18</sup>F](#), [<sup>18</sup>Ne](#), [<sup>18</sup>Na](#), [<sup>18</sup>Mg](#)

B. General Tables:

[Table 18.1](#): General table for <sup>18</sup>C

[Table 18.3](#): General table for <sup>18</sup>N

[Table 18.8](#): General table for <sup>18</sup>O

[Table 18.23](#): General table for <sup>18</sup>F

[Table 18.35](#): General table for <sup>18</sup>Ne

C. Tables of Recommended Level Energies:

[Table 18.2](#): Energy levels of <sup>18</sup>C

[Table 18.4](#): Energy levels of <sup>18</sup>N

[Table 18.9](#): Energy levels of <sup>18</sup>O

[Table 18.24](#): Energy levels of <sup>18</sup>F

[Table 18.36](#): Energy levels of <sup>18</sup>Ne

D. [References](#)

E. Figures: [<sup>18</sup>N](#), [<sup>18</sup>O](#), [<sup>18</sup>F](#), [<sup>18</sup>Ne](#), [Isobar diagram](#)

F. Erratum to the Publication: [PS](#) or [PDF](#)

### $^{18}\text{He}$

(Not illustrated)

Not observed: See (1982AV1A, 1983ANZQ).

### $^{18}\text{Li}$

(Not illustrated)

$^{18}\text{Li}$  has not been observed. Shell model calculations described in (1988POZS) predict the ground-state magnetic dipole moment and charge and matter radii.

### $^{18}\text{Be}$

(Not illustrated)

$^{18}\text{Be}$  has not been observed. It is predicted to have a mass excess of 78.43 MeV: see (1978AJ03).  $^{18}\text{Be}$  is then unstable with respect to breakup into  $^{16}\text{Be} + 2n$ ,  $^{15}\text{Be} + 3n$ ,  $^{14}\text{Be} + 4n$ ,  $^{13}\text{Be} + 5n$ ,  $^{12}\text{Be} + 6n$ ,  $^{11}\text{Be} + 7n$  and  $^{10}\text{Be} + 8n$  by, respectively 3.01, 3.04, 6.26, 2.92, 4.93, 1.76 and 1.26 MeV, using the masses for the residual nuclei adopted by (1991AJ01, 1993AU05, 1993TI07). See also (1983ANZQ, 1989OG1B).

### $^{18}\text{B}$

(Not illustrated)

$^{18}\text{B}$  has not been observed in the bombardment of Ta by 44 MeV/A Ar ions (1985DE60, 1985LA03, 1986PO13) or in the bombardment of Be by 12 MeV/A  $^{56}\text{Fe}$  ions (1984MU27).  $^{18}\text{B}$  has been predicted to have a mass excess of 52.3 MeV (1993AU05). It would then be unstable with respect to  $^{17}\text{B} + n$  by 0.5 MeV: see (1978AJ03, 1985WA02).  $^{18}\text{B}$  is calculated to have  $J^\pi = 4^-$  and to have excited states at 0.62, 0.86 and 1.59 MeV with  $J^\pi = 1^-, 2^-$  and  $2^-$  (1985PO10). The shell model calculations of (1992WA22) predict  $J^\pi = 2^-$  for the ground state with the first three excited states at 0.45, 0.52, 0.839 MeV with  $J^\pi = 4^-, 2^-, 3^-$ . See also (1987AJ02, 1988GUZT).

### $^{18}\text{C}$

(Figs. 1 and 5)

GENERAL: See Table 18.1.

*Mass of  $^{18}\text{C}$ :* The atomic mass excess of  $^{18}\text{C}$  adopted by (1993AU05) is  $24.920 \pm 0.030$  MeV, based on the  $Q$ -value of the  $^{48}\text{Ca}(^{18}\text{O}, ^{18}\text{C})^{48}\text{Ti}$  reaction.  $^{18}\text{C}$  is then bound by 4.188 MeV with respect to breakup into  $^{17}\text{C} + n$ . See also (1982FI10, 1987AJ02, 1992WA22).

Table 18.1:  $^{18}\text{C}$  – General

Reference	Description
Reviews:	
1987GIIC	Pion-nucleus interactions
1989AJ1A	Summary of recent work involving light nuclei (Sec. 4.2 covers $^{18}\text{C}$ )
1989DE52	Exotic light nuclei: production, mass meas., decay, & complex reactions
1989VOZM	History of & future prospects for production of nuclei far from stability
1994BO1H	Summary of recent research employing radioactive nuclear beams
Other Articles:	
1987BL18	Gogny's effective interaction used to calc. ground & excited states of light nuclei
1987SN01	Partitioning of 2 component particle syst. & isotope distrib. in nucl. fragmentation
1988POZS	Shell-model calcs. of exotic light nucl. ground state props. compared to exp. data
1989RA16	Predxns. from systematics & tabulation of $B(E2; 0_1^+ \rightarrow 2_1^+)$ values for even-even nucl.
1989SA10	Total cross sections of reactions induced by neutron-rich light nuclei
1990LO11	Self-consistent calcs. of light neutron-rich nuclei using density-functional method
1990ST08	2nd-generation microscopic predictions of $\beta$ -decay half-lives of neutron-rich nuclei
1991RE02	Meas. half-lives & neutron emission probabilities of neutron-rich Li-Al nuclei
1992LA13	Influence of separation energy on the radius of neutron-rich nuclei
1992WA22	Effective interactions for the $0p1s0d$ nuclear shell-model space
1993PA14	Relativistic mean field theory; calc. binding energy, rms radii, deformation parameters

1.  $^{18}\text{C}(\beta^-)^{18}\text{N}$   $Q_m = 11.807$

The half-life of  $^{18}\text{C}$  has been measured to be  $66_{-18}^{+25}$  ms (1988MU08),  $78_{-15}^{+20}$  ms (1989LE16),  $94 \pm 27$  ms (1991RE02),  $(95 \pm 10)$  ms (1991PR03).

Branching to states in  $^{18}\text{N}$  has been measured by (1991PR03) and is presented here in Table 18.6. These authors also measured the total branching probability to gamma emitting states plus the ground state of  $^{18}\text{N}$  to be  $P_\gamma = (81 \pm 5)\%$ . The  $\beta$ -delayed neutron emission probability is  $P_n = 1 - P_\gamma = (19 \pm 5)\%$ . Other values reported for  $P_n$  are  $(25 \pm 4.5)\%$  (1988MU08),  $(50 \pm 10)\%$  (1989LE16),  $(43.3 \pm 6.5)\%$  (1991RE02). The  $^{18}\text{C}(\beta^-)$  decay is also discussed in the analysis of Gamow-Teller rates presented in (1993CH06). Experimental Gamow-Teller matrix elements are compared with results of shell-model calculations.

2.  $^{18}\text{O}(\pi^-, \pi^+)^{18}\text{C}$   $Q_m = -25.706$

Table 18.2: Energy levels of  $^{18}\text{C}$

$E_x$ in $^{18}\text{C}$ (MeV $\pm$ keV)	$J^\pi; T$	$\tau_{1/2}$ (ms)	Decay	Reactions
0	$(0^+); 3$	$95 \pm 10$	$(\beta^-)$	2, 3
$1.62 \pm 20$	$(2^+); 3$			2, 3

The angular distribution of the  $\pi^+$  to the ground state of  $^{18}\text{C}$  has been measured at  $E_{\pi^-} = 164$  MeV by (1984GI10) [see also for excitation function at  $\theta = 5^\circ$  for  $E_{\pi^-} \approx 140$  to 240 MeV]. There is also some indication of the population of an excited state at  $E_x = 1.55$  MeV (1984GI10). See also (1983AJ01).

$$3. \text{}^{48}\text{Ca}(\text{}^{18}\text{O}, \text{}^{18}\text{C})\text{}^{48}\text{Ti} \quad Q_m = -21.434$$

At  $E(^{18}\text{O}) = 112$  MeV the ground state and an excited state at  $1.62 \pm 0.024$  MeV are observed by (1982FI10). See also (1983AJ01).

### $^{18}\text{N}$ (Figs. 1 and 5)

GENERAL: See Table 18.3.

*Mass of  $^{18}\text{N}$ :* The atomic mass excess derived from the  $Q$ -value of the  $^{18}\text{O}(\text{}^7\text{Li}, \text{}^7\text{Be})\text{}^{18}\text{N}$  reaction and adopted by (1993AU05) is  $13.117 \pm 0.020$  MeV (1983PU01).  $^{18}\text{N}$  is then stable with respect to breakup into  $^{17}\text{N} + n$  by 2.825 MeV. See (1983AJ01) for the earlier work.

$$1. \text{}^{18}\text{N}(\beta^-)\text{}^{18}\text{O} \quad Q_m = -13.899$$

The half-life of  $^{18}\text{N}$  is  $0.624 \pm 0.012$  s (1982OL01). The decay branches are displayed in Table 18.18. The nature of the decay leads to  $J^\pi = 1^-$  for the  $^{18}\text{N}$  ground state (1982OL01). See also (1983SN03), and see the measurements on beta branching reported in (1989ZH04) which indicate a total branching ratio to alpha-particle-emitting states in  $^{18}\text{O}$  of at least 12.2%. A delayed-neutron emission probability  $P_n = (14.3 \pm 2.0)\%$  was measured by (1991RE02). More recently a study reported by (1994SC01) gave  $P_n = (2.2 \pm 0.4)\%$  for transitions to neutron unstable states in  $^{18}\text{O}$  above  $E_x = 9.0$  MeV. See also reaction 22 under  $^{18}\text{O}$ .

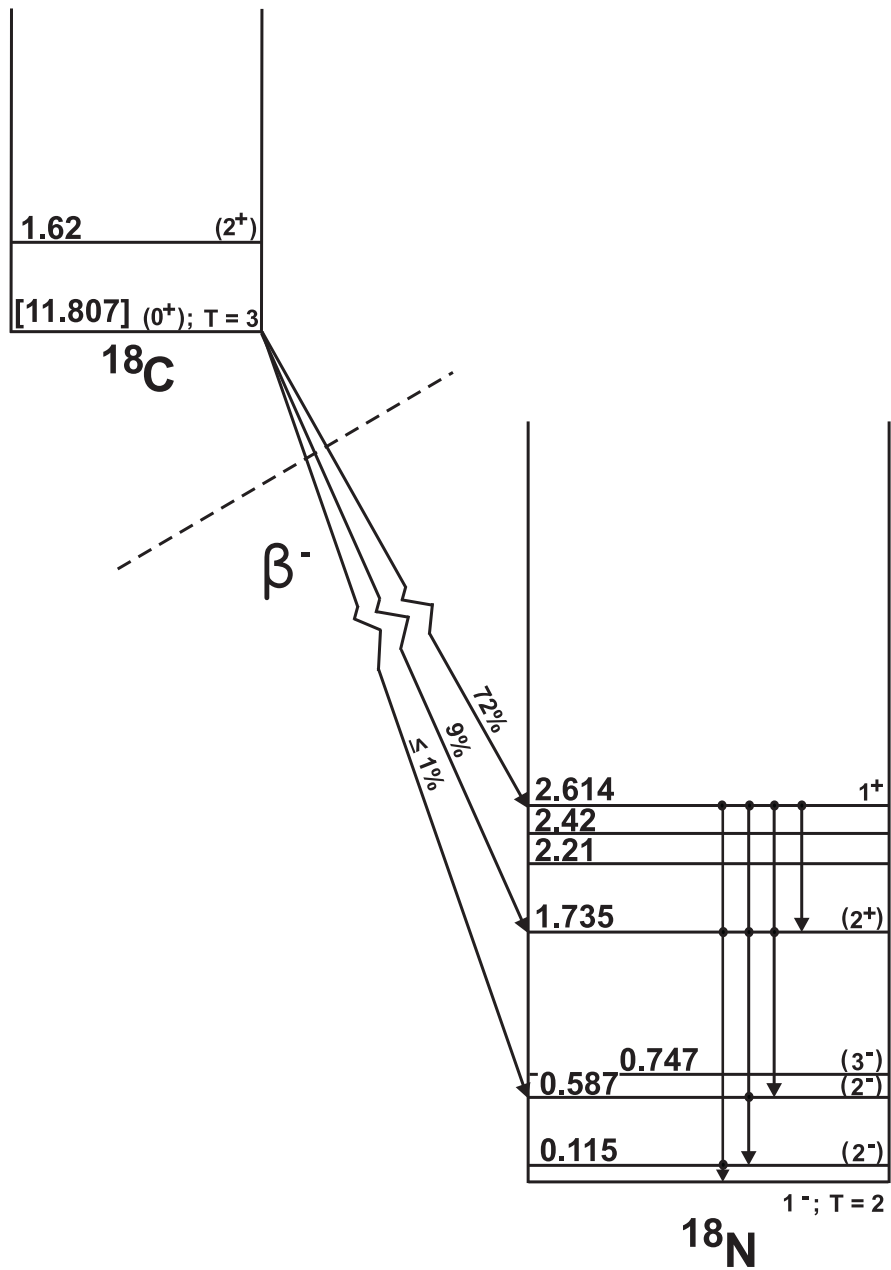

06-2013

Fig. 1: Energy levels of  $^{18}\text{C}$  and  $^{18}\text{N}$ . For notation see Fig. 2. For more detailed  $\beta^-$  branching information see  $^{18}\text{C}$  reaction 1.

Table 18.3:  $^{18}\text{N}$  – General

Reference	Description
Reviews:	
<a href="#">1988MI1J</a>	Shell model transition densities for electron and pion scattering
<a href="#">1990TH1E</a>	Summary of topics presented at Workshop on Primordial Nucleosynthesis
<a href="#">1994BO1H</a>	Summary of recent research employing radioactive nuclear beams
Other Articles:	
<a href="#">1987AN1A</a>	Use of LISE spectrometer at GANIL for identification of exotic light nuclei
<a href="#">1987RI03</a>	Isotopic distributions of fragments in $^{40}\text{Ar} + ^{68}\text{Zn}$ at 27.6 MeV/nucleon
<a href="#">1987SA25</a>	LISE spectrometer at GANIL: results of search for new exotic nuclei
<a href="#">1989SA10</a>	Total cross sections of reactions induced by neutron-rich light nuclei
<a href="#">1991RE02</a>	Meas. half-lives & neutron emission probabilities of neutron-rich Li-Al nuclei
<a href="#">1993PA14</a>	Relativistic mean field theory; calc. binding energy, rms radii, deformation parameters

$$2. \ ^{14}\text{C}(^7\text{Li}, ^3\text{He})^{18}\text{N} \quad Q_m = -10.121$$

The preliminary work described in ([1983AJ01](#)) has not been published.

$$3. \ ^{14}\text{C}(^{18}\text{O}, ^{14}\text{N})^{18}\text{N} \quad Q_m = -13.740$$

At  $E(^{18}\text{O}) = 92.2$  MeV groups are observed to the ground state of  $^{18}\text{N}$  (unresolved) and to an excited state at  $E_x = 575 \pm 25$  keV ([1980NA14](#)).

$$4. \ ^{18}\text{C}(\beta^-)^{18}\text{N} \quad Q_m = 11.807$$

See reaction 1 under  $^{18}\text{C}$ . Branching to states in  $^{18}\text{N}$  was measured by ([1991PR03](#)) and is presented here in Table [18.6](#). These authors measured the total branching probability to gamma emitting states of  $^{18}\text{N}$  to be  $P_\gamma = 81 \pm 5$  %. Measurements of  $\gamma$ -ray energies and branching lead to the level energies displayed in Table [18.7](#) and  $^{18}\text{N}$  radiative decays in Table [18.5](#).

$$5. \ ^{18}\text{O}(\pi^-, \pi^0)^{18}\text{N} \quad Q_m = -9.305$$

Table 18.4: Energy levels of  $^{18}\text{N}$

$E_x(\text{MeV} \pm \text{keV})$	$J^\pi; T$	$\tau_{1/2}$ (ms)	Decay	Reactions
0	$1^-; 2$	$624 \pm 12$	$\beta^-$	1, 3, 5, 6, 7
$0.11490 \pm 0.18^a$	$(2^-)^b$		$\gamma$	3, 4, 5, 7
$0.58756 \pm 0.24$	$(2^-)^b$		$\gamma$	3, 4, 7, 8
$0.747 \pm 10$ c	$(3^-)^b$			7
$1.73485 \pm 0.22^a$	$(2^+)^d$		$\gamma$	4
2.21				7
2.42				7
$2.61445 \pm 0.23^a$	$1^+ \text{ a,d}$		$\gamma$	4

<sup>a</sup> Level energies determined from  $\gamma$  energies reported in (1991PR03).

<sup>b</sup> Suggested by (1984BA24). See also (1982OL01).

<sup>c</sup> See (1984BA24) for a calculation suggesting additional states in this energy region.

<sup>d</sup> (1993CH06).

Table 18.5: Radiative decays in  $^{18}\text{N}^a$

$E_i$ (MeV)	$J_i^\pi$	$E_f$ (MeV)	Branch (%)
0.115	$(2^-)$	0	100
0.587	$(2^-)$	0.115	$100 \pm 16$
1.735	$(2^+)$	0	$33 \pm 8$
		0.115	$38 \pm 9$
		0.587	$29 \pm 10$
2.614	$1^+$	0	$49 \pm 8$
		0.115	$22 \pm 6$
		0.587	$3 \pm 2$
		1.735	$26 \pm 6$

<sup>a</sup> (1991PR03).



Table 18.6: Branchings in  $^{18}\text{C}(\beta^-)^{18}\text{N}$

Decay to $^{18}\text{N}^*$ (MeV)	Branch <sup>a</sup> (%)	$\log ft$ <sup>b</sup>
0.115		
0.587	$\leq 1$	$\geq 6.4$
1.735	$9 \pm 7$	$5.2 \pm 0.4$
2.614	$72 \pm 10$	$4.08 \pm 0.08$

<sup>a</sup> (1991PR03), calculated with the hypothesis that there is no direct  $\beta$ -feeding of the 0.115 MeV level. The total probability of  $\beta$  decay to gamma emitting states plus to the ground state is  $P_\gamma = (81 \pm 5)\%$ . The  $\beta$ -delayed neutron probability is  $P_n = 1 - P_\gamma$ .

<sup>b</sup>  $\log ft$ 's were recalculated by evaluators and are slightly different from those in (1991PR03) due to use of level energies from Table 18.4 and  $Q$ -values from (1993AU05).

Table 18.7:  $\gamma$ -ray intensities in  $^{18}\text{C}(\beta^-)^{18}\text{N}$  <sup>a</sup>

$E_\gamma$ (keV)	$E_i$ (keV)	$E_f$ (keV)	$I_\gamma$ <sup>b</sup>
$114.9 \pm 0.2$	115	0	$36.5 \pm 7.5$
$472.7 \pm 0.2$	587	115	$10.2 \pm 4.0$
$879.7 \pm 0.2$	2614	1735	$18.7 \pm 5.0$
$1147.8 \pm 0.4$	1735	587	$8.0 \pm 3.7$
$1619.9 \pm 0.3$	1735	115	$10.5 \pm 4.1$
$1734.8 \pm 0.4$	1735	0	$9.1 \pm 3.6$
$2025.3 \pm 0.8$	2614	587	$2.2 \pm 1.5$
$2499.3 \pm 0.4$	2614	115	$15.8 \pm 4.8$
$2614.2 \pm 0.4$	2614	0	$35.3 \pm 7.6$

<sup>a</sup> (1991PR03).

<sup>b</sup>  $\gamma$ -ray intensities are per 100 parent decays.

See (1983AS01, 1984AS05).

$$6. {}^{18}\text{O}(t, {}^3\text{He}){}^{18}\text{N} \quad Q_m = -13.880$$

See (1983AJ01).

$$7. {}^{18}\text{O}({}^7\text{Li}, {}^7\text{Be}){}^{18}\text{N} \quad Q_m = -14.761$$
$$Q_0 = -14761 \pm 20 \text{ keV (1983PU01)}$$

At  $E({}^7\text{Li}) = 52 \text{ MeV}$ ,  ${}^7\text{Be}$  groups are observed corresponding to the excitation of the states displayed in Table 18.4 here (1983PU01).

$$8. {}^{18}\text{O}({}^{11}\text{B}, {}^{11}\text{C}){}^{18}\text{N} \quad Q_m = -15.881$$

See (1983PU01).

<sup>18</sup>O  
(Figs. 2 and 5)

GENERAL: See Table 18.8.

$$\text{Isotopic abundance} = (0.200 \pm 0.012)\% \text{ (1984DE53).}$$

$$\langle r^2 \rangle^{1/2} = 2.784 \pm 0.020 \text{ fm: see reaction 25.}$$

<sup>18</sup>O\*(1.98)

$$g = -0.287 \pm 0.015 \text{ [see (1983AJ01)].}$$

$Q = -0.042 \pm 0.008$  b. [weighted mean of  $-0.036 \pm 0.009$  and  $-0.058 \pm 0.015$  b: see (1983GR28); see also (1983AJ01)].

$$\begin{aligned} B(E2; 0^+ \rightarrow 2^+) &= 39.0 \pm 1.8 e^2 \cdot \text{fm}^4 \text{ [(1979FE06, 1983GR10); see also (1983AJ01)];} \\ &= 44.8 \pm 1.3 e^2 \cdot \text{fm}^4 \text{ (1982NO04);} \\ &= 47.6 \pm 1.0 e^2 \cdot \text{fm}^4 \text{ (1982BA06); see also (1987RA01).} \end{aligned}$$

For a discussion of the hexadecapole deformation see (1983GR10). See also (1987RA01).

- |  |                |
|--|----------------|
| 1. (a) <sup>7</sup> Li( <sup>11</sup> B, nn) <sup>16</sup> O | $Q_m = 12.171$ |
| (b) <sup>9</sup> Be( <sup>9</sup> Be, nn) <sup>16</sup> O    | $Q_m = 11.291$ |

Reactions (a) and (b) have been studied by (1993CU01, 1993DA17) in low energy heavy-ion fusion reactions. It is reported that the  $\approx 3$  MeV wide resonance observed at  $E_x(^{18}\text{O}) \approx 28$  MeV in the <sup>7</sup>Li + <sup>11</sup>B  $\rightarrow$  <sup>18</sup>O  $\rightarrow$  <sup>16</sup>O + nn and <sup>9</sup>Be + <sup>9</sup>Be  $\rightarrow$  <sup>18</sup>O  $\rightarrow$  <sup>16</sup>O + nn reactions overlap with the higher part of the  $T_{<} = 1$ , <sup>18</sup>O GDR observed in photonuclear excitation.

---

Fig. 2: Energy levels of <sup>18</sup>O. In these diagrams, energy values are plotted vertically in MeV, based on the ground state as zero. Uncertain levels or transitions are indicated by dashed lines; levels which are known to be particularly broad are cross-hatched. Values of total angular momentum  $J$ , parity, and isobaric spin  $T$  which appear to be reasonably well established are indicated on the levels; less certain assignments are enclosed in parentheses. For reactions in which <sup>18</sup>O is the compound nucleus, some typical thin-target excitation functions are shown schematically, with the yield plotted horizontally and the bombarding energy vertically. Bombarding energies are indicated in laboratory coordinates and plotted to scale in cm coordinates. Excited states of the residual nuclei involved in these reactions have generally not been shown; where transitions to such excited states are known to occur, a brace is sometimes used to suggest reference to another diagram. For reactions in which the present nucleus occurs as a residual product, excitation functions have not been shown; a vertical arrow with a number indicating some bombarding energy, usually the highest, at which the reaction has been studied, is used instead. Further information on the levels illustrated, including a listing of the reactions in which each has been observed, is contained in the master table, entitled "Energy levels of <sup>18</sup>O". For more detailed  $\beta^-$  branching information, see <sup>18</sup>N reaction 1.

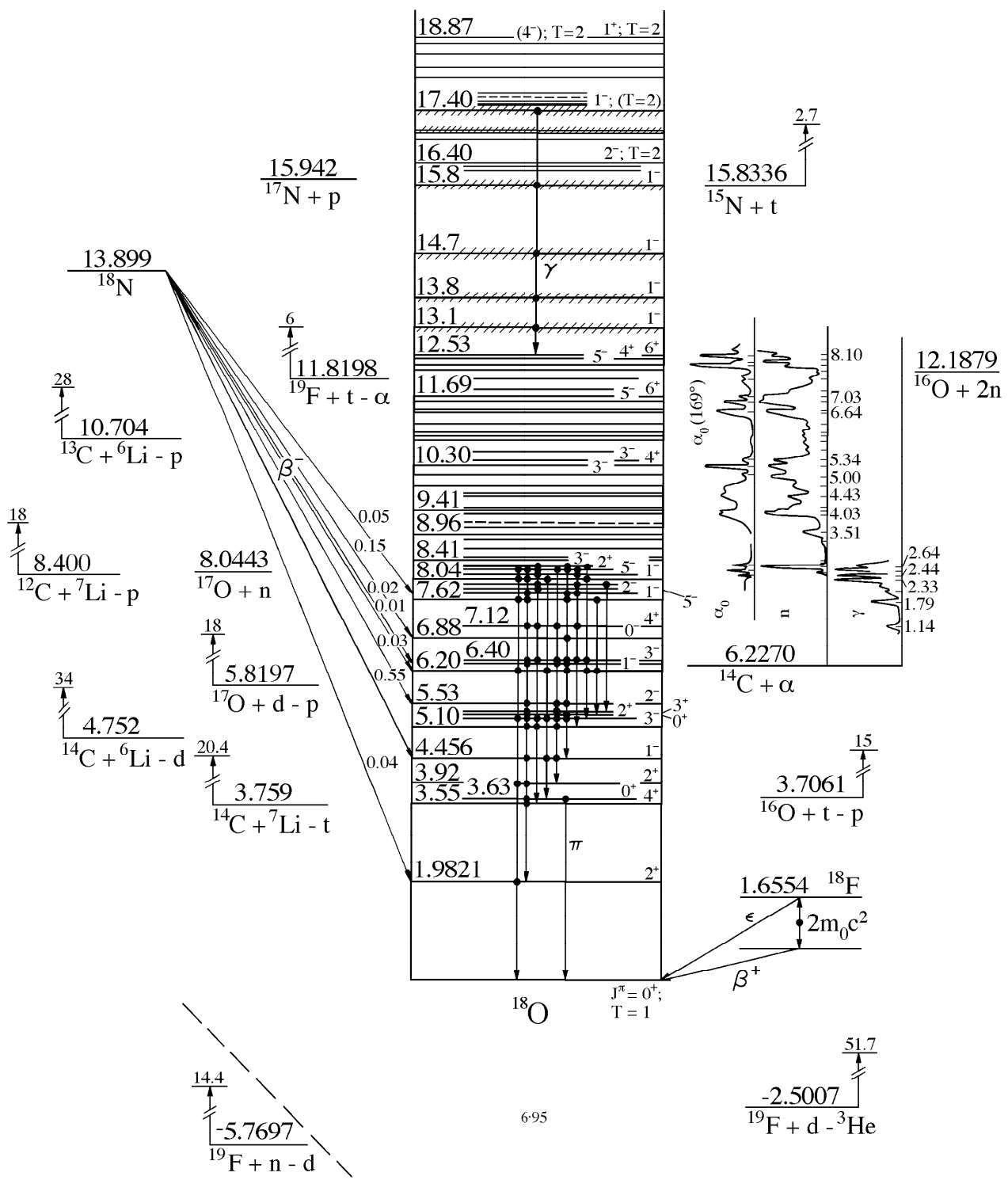

Table 18.8:  $^{18}\text{O}$  – General

Reference	Description
Shell model	
Review:	
<a href="#">1988BR1P</a>	Status of the nuclear shell model
Other articles:	
<a href="#">1987CH1J</a>	Nucl. struc. calcs. using mixed-config. shell model: effective & surface $\delta$ -interactions
<a href="#">1987LE1L</a>	Low-lying non-normal parity states of $^{18}\text{O}$ & $^{18}\text{F}$ calculated in shell model + tensor force
<a href="#">1987MU16</a>	Relativistic effects in the low-energy spectra of 1s0d-shell nuclei
<a href="#">1987SH1O</a>	Validity of M-3Y force equivalent G-matrix element for s-d shell nucl. struc. calcs.
<a href="#">1988BR11</a>	Semi-empirical effective interactions for the 1s-0d shell
<a href="#">1988FI01</a>	Effective interactions for sd-shell-model calculations
<a href="#">1988HI05</a>	Effect on Gamow-Teller strength of config. mixing and p-n correl. in e-e sd-shell nucl.
<a href="#">1989GU06</a>	Hartree-Fock & shell-model charge densities calc. for $^{16,18}\text{O}$ , $^{32,34}\text{S}$ , $^{40,48}\text{Ca}$
<a href="#">1989HJ03</a>	Effective interactions through 3rd order for $A = 18$ nuclei with the Paris potential
<a href="#">1989OR02</a>	Empirical isospin-nonconserving Hamiltonians for shell-model calculations
<a href="#">1990HJ01</a>	3rd order number-conserving sets & effective interactions calc. with Bonn-Jülich potential
<a href="#">1990HJ03</a>	Choice of single-particle potential & the convergence of the effective interaction
<a href="#">1990MI01</a>	Shell model states in the $^{18}\text{O}$ three-body wave function from Faddeev formalism
<a href="#">1990SK04</a>	Study of $A = 18$ nuclei and the effective interaction in the sd shell
<a href="#">1992FR01</a>	Nuclear charge radii systematics in the sd shell from muonic atom measurements
<a href="#">1992HJ01</a>	Folded-diagram effective interactions with the Bonn meson-exchange potential model
<a href="#">1992JI04</a>	Bonn potential used to evaluate energy spectra of some light sd-shell nuclei
<a href="#">1992OS01</a>	Spin-tensor analysis of realistic shell model interactions
<a href="#">1994VE04</a>	Exp. meas. & calc. of spectroscopic factors from one-proton stripping rxns. on sd-shell nucl.
Cluster models	
<a href="#">1988KU17</a>	Microscopic boson descrip. of p-n systems applied to electron scat. from $^{18}\text{O}$ , $^{20}\text{Ne}$
<a href="#">1989FU08</a>	Microscopic multichannel calc. of the molecular dipole degree of freedom in $^{18}\text{O}$
<a href="#">1989TR18</a>	2-nucleon and 4-nucleon clusters in light & heavy nuclei
<a href="#">1990OS03</a>	Cluster-stripping reactions in the heavy-ion collisions (includes $^{14}\text{C}(^6\text{Li}, d)^{18}\text{O}$ )

Table 18.8 from (1995TI07):  $^{18}\text{O}$  – General (continued)

Reference	Description
Special states	
Review:	
1988BR1P	Status of the nuclear shell model
1989RA17	Compilation of exp. data on nuclear moments for ground & excited states of nucl.
Other articles:	
1987BL18	Gogny's effective inter. used to calc. gnd. & excited states of specific spin-isospin order
1987CH1J	Nucl. struc. calcs. using mixed-config. shell model: effective & surface $\delta$ -interactions
1987LE1L	Non-normal parity states of $^{18}\text{O}$ & $^{18}\text{F}$ calculated in shell model + tensor force
1987LI1F	Double delta & surface delta interactions used to calc. low-lying spectra of $^{17-22}\text{O}$
1987MU16	Relativistic effects in the low-energy spectra of 1s0d-shell nuclei
1987SH1O	Validity of M-3Y force equivalent G-matrix element for s-d shell nucl. struc. calcs.
1987VA19	Microscopic analysis of excitation of first $2^+$ state of $^{18}\text{O}$ on $^{64}\text{Ni}$
1988KU17	Microscopic boson descrip. of p-n systems applied to electron scat. from $^{18}\text{O}$ & $^{20}\text{Ne}$
1989FU08	Microscopic multichannel calculation of the molecular dipole degree of freedom in $^{18}\text{O}$
1989HJ03	Effective interactions through 3rd order for $A = 18$ nuclei with the Paris potential
1989OR02	Empirical isospin-nonconserving Hamiltonians for shell-model calculations
1990MI01	Shell model states in the $^{18}\text{O}$ three-body wave function from Faddeev formation
1990SK04	Study of $A = 18$ nuclei and the effective interaction in the sd shell
Electromagnetic	
Review:	
1989RA17	Compilation of exp. data on nuclear moments for ground & excited states of nucl.
1993EN03	Strengths of $\gamma$ -ray transitions in $A = 5 - 44$ nuclei
Other articles:	
1987CH1J	Nucl. struc. calcs. using mixed-config. shell model: effective & surface $\delta$ -interactions
1989FU08	Microscopic multichannel calc. of the molecular dipole degree of freedom in $^{18}\text{O}$
1989RA16	Predxns. from systematics & tabulation of $B(E2; 0_1^+ \rightarrow 2_1^+)$ values for even-even nucl.
1989SP01	Reduced electric-octupole transition probabilities, $B(E3; 0_1^+ \rightarrow 3_1^-)$ , for even-even nucl.
1990NO1A	Calcs. of electric quadrupole excitations in relativistic nucleus-nucleus collisions
1993EG04	Calc. of transition probs. with angular-momentum-projected wave functions & realistic forces

Table 18.8 from (1995TI07):  $^{18}\text{O}$  – General (continued)

Reference	Description
Astrophysics	
Reviews:	
1988HU1E	Chronrules: chemical, mineralogical & isotopic constraints on theories of their origin
1989GU1L	Chemical analyses of cool stars (includes isotopic abundance ratios)
1989WH1B	Abundance ratios as a function of metallicity
1990AR10	Nuclear reactions in astrophysics
1990TH1E	Summary of topics presented at Workshop on Primordial Nucleosynthesis
1993MA1M	Review of primordial nucleosynthesis beyond the standard big bang
Other articles:	
1987BE1H	$^{12}\text{C}/^{13}\text{C}$ & $^{16}\text{O}/^{18}\text{O}$ ratios in Venus' atmosphere from high-res. 10- $\mu\text{m}$ spectroscopy
1987FA1C	$^{16}\text{O}$ excess in hibonites discredits late supernova injection origin of isotopic anomalies
1987SO1E	Interstellar shock waves related to high $^{10}\text{Be}$ & $^{18}\text{O}$ concentrations in ice cores
1987WA1F	Abundances in red giant stars: C & O isotopes in carbon-rich molecular envelopes
1988BE1B	Past solar activity & geomagnetism info. from $^{10}\text{Be}$ & $^{18}\text{O}$ concentrations in ice cores
1988BU01	Stellar reaction rates of $\alpha$ capture on light $N \neq Z$ nuclei & astrophysical implications
1988CA26	Analytic expressions for thermonuclear reaction rates involving $Z \leq 14$ nucl.
1989JI1A	Nucleosynthesis inside thick accretion disks around massive black holes
1989ME1C	Isotope abundances of solar coronal material derived from solar energetic particle meas.
1990MA1Z	Nuclear reaction uncertainties in standard & non-standard cosmologies
1990ST1G	High spatial resolution isotopic CO & CS observations of M17 SW
1990TO1F	$\text{C}^{18}\text{O}$ in the Chameleon 1 dark cloud (a nearby site of low-mass star formation)
1991KO31	$^{17}\text{O}(n, \alpha)^{14}\text{C}$ cross section measured from 25 meV to approximately 1 MeV
1991SA1F	Extragalactic $^{18}\text{O}/^{17}\text{O}$ ratios imply high-mass stars preferred in starburst systems
1992GA11	Implications of the $^{14}\text{C}(\alpha, \gamma)^{18}\text{O}$ reaction for nonstandard big bang nucleosynthesis
1992GO14	Alpha capture on $^{14}\text{C}$ from $E_{\alpha} = 1.14$ to 2.33 MeV and its astrophysical implications
1993GA1G	Secondary radioactive beams used to measure cross sections of astrophysical importance
1994BE29	Neutron capture rates of light isotopes for inhomogeneous Big Bang nucleosynthesis

### Applications

Reviews:

- 1987SE1D Progress in the field of accelerator mass spectrometry (1977 – 1987)  
 1989KU1P Production and application of stable enriched isotopes in the USSR

Table 18.8 from (1995TI07):  $^{18}\text{O}$  – General (continued)

Reference	Description
Applications – continued	
Other articles:	
1987MC1A	O isotopes in refractory stratospheric dust particles: proof of extraterrestrial origin
1987ZU1A	Oxygen isotope effect in high-temperature oxide superconductors
1988FA1A	Extreme $^{18}\text{O}$ depletion in calcite & chert clasts from Elephant Moraine (in Antarctica)
1988FI1C	Assessment of $^{18}\text{O}$ enriched water as a marker of total body water (A)
1988HI1F	Design & uses of target systems used to produce positron emitters (A)
1988HI1G	The oxygen isotope effect in $\text{Ba}_{0.625}\text{K}_{0.375}\text{BiO}_3$ (a high-temp. superconducting oxide)
1988KH06	Threshold track detectors used to study interaction of $^{18}\text{O}$ ions w/ light & heavy targets
1988MI1B	O-isotope analyses & deep-sea temp. changes: implications for rates of oceanic mixing
1988NW1A	Measurement of oil reservoir rock dispersivity by nuclear reaction analysis (A)
1989GR1F	Brachiopod calcite record of oceanic C & O isotope shifts at Permian/Triassic transition
1989NW1A	Assessment of $^{18}\text{O}$ enriched water as a marker of total body water
1989TA1Y	Separation of N & O isotopes by liquid chromatography
1990CH1I	$^{18}\text{O}$ isotope studies on redistribution of O obtained in O ion implantation
1990CO1K	Determination of $^{18}\text{O}$ concentrations in microsamples of biological fluids
1990MI15	Determination of absolute oxygen coverage by nuclear reaction analysis
1990SA1J	O isotope evidence for a stronger winter monsoon current during the last glaciation

#### Complex reactions

1986MA13	Experimental search for nonfusion yield in heavy residues emitted from $^{11}\text{B} + ^{12}\text{C}$
1987BE1I	Search for a nucleon-participant multiplicity effect on anomalous fragment production
1987BU07	Projectile-like fragments from $^{20}\text{Ne} + ^{197}\text{Au}$ – counting simultaneously emitted neutrons
1987HE1H	Search for anomalously heavy isotopes of low $Z$ nuclei
1987VA19	Microscopic analysis of excitation of first $2^+$ state of $^{18}\text{O}$ on $^{64}\text{Ni}$
1988BE56	Light nuclei formation in reactions of B & Ne ions with Ta & Th at $E = 18 - 20 \text{ MeV/A}$



Table 18.8 from (1995TI07):  $^{18}\text{O}$  – General (continued)

Reference	Description
Complex reactions – continued	
1988BL11	Systematics of cluster-radioactivity-decay constants as suggested by microscopic calcs.
1988KH06	Threshold track detectors used to study interaction of $^{18}\text{O}$ ions w/ light & heavy targets
1988PR1C	Target & projectile mass dependence of charge pickup reactions by $\approx \text{GeV}/N$ nuclei (A)
1988UT02	Extended Serber model applied to quasi-free stripping reactions
1989GE11	Complex fragments emitted in excited states
1989SA10	Total cross sections of reactions induced by neutron-rich light nuclei
1989TE02	Dissipative mechanisms in the 120 MeV $^{19}\text{F} + ^{64}\text{Ni}$ reaction
1989YO02	Quasi-elastic & deep inelastic transfer in $^{16}\text{O} + ^{197}\text{Au}$ for $E < 10 \text{ MeV}/u$
1990LE08	Statistical equilibrium in the $^{40}\text{Ar} + ^{12}\text{C}$ system at $E/A = 8 \text{ MeV}$
1990LI1J	$Z$ dependence of Coulomb dissociation cross sections in heavy ion reactions
Antimatter	
Reviews:	
1986KO1E	Search for $\bar{p}$ -atomic X-rays at LEAR
1987GR1I	Low energy antiproton physics in the early LEAR era
1987VO1B	Interaction and annihilation of antiprotons and nuclei
1987YA1E	Summary of scattering results at LEAR & unique features of the $(\bar{p}, \bar{n})$ reaction
Other articles:	
1987AD04	Microscopic analysis of antiproton-nucleus elastic scattering
1987GR20	Widths of $4f$ antiprotonic levels in the oxygen region
1987HA1J	Widths of $4f$ antiprotonic levels in the O region using realistic nucl. wavefunctions
1988LI1O	Optical model analysis of antiproton-nucleus elastic scattering (in Chinese)
1989CH13	Phenomenological model analysis of scattering of $\approx 180 \text{ MeV}$ antiprotons from nuclei
1989HE21	Microscopic analysis of antiproton elastic scattering on even-even nuclei
1989MA24	Microscopic analysis of antiproton-nucleus inelastic scattering at $600 \text{ MeV}/c$
1992TA08	Eikonal and Glauber calculations of scattering of antiprotons on $^{18}\text{O}$ at $180 \text{ MeV}$

Table 18.8 from (1995TI07):  $^{18}\text{O}$  – General (continued)

Reference	Description
Other topics	
Review:	
1988BA82	Use of reactions involving pions & kaons in the study of heavy hypernuclei
1993PE19	Overview of new experimental results in meson-nucleus interactions & future opportunities
Other articles:	
1987BL18	Gogny's effective interaction used to calc. ground & excited states of light nuclei
1988HI05	Effect on Gamow-Teller strength of config. mixing & p-n correl. in e-e sd-shell nucl.
1988KA39	Coulomb effects in the 4-body model of simultaneous 2n transfer induced by heavy ions
1988TR02	Interacting boson scheme for light nuclei
1989BA92	Evaluation of hypernucleus production cross-sections in relativistic heavy-ion collisions
1989OR02	Empirical isospin nonconserving Hamiltonians for shell-model calculations
1989TA32	Schmidt diagrams & configuration mixing effects on hypernuclear magnetic moments
1990BR13	Empir. p-n interactions: global trends, configuration sensitivity & $N = Z$ enhancements
1990HJ01	3rd order number-conserving sets & effective interactions calc. with Bonn-Jülich potential
1990KA1F	Theoretical aspects of nuclear parity violation
1990SK04	Study of the $A = 18$ nuclei and the effective interaction in the sd shell
1994CI02	Specific heat and shape transitions in light sd nuclei
1994LU01	Deep pionic bound states in a nonlocal optical potential
Ground state properties	
Review:	
1989RA17	Compilation of exp. data on nuclear moments for ground & excited states of nucl.
Other articles:	
1987BL18	Gogny's effective inter. used to calc. gnd. & excited states of specific spin-isospin order
1988GU03	Charge-density distribution of 1s-1p & 1d-2s shell nuclei & filling numbers of the states
1989CH1P	1s-0d effective interxns. of isospin triplet & $^{18}\text{Ne}$ - $^{18}\text{O}$ Coulomb displacmt. energ. (in Chin.)
1989GU06	Hartree-Fock & shell-model charge densities calc. for $^{16,18}\text{O}$ , $^{32,34}\text{S}$ , $^{40,48}\text{Ca}$
1989SA10	Total cross sections of reactions induced by neutron-rich light nuclei
1989TR18	2-nucleon & 4-nucleon clusters in nuclei

Table 18.8 from (1995TI07):  $^{18}\text{O}$  – General (continued)

Reference	Description
Ground state properties – continued	
1990GU10	Charge densities of sp- and sd-shell nuclei & occupation numbers of 2s states
1990LO11	Self-consistent calcs. of light neutron-rich nuclei using density-functional method
1992FR01	Behavior of nuclear charge radii systematics in the sd shell from muonic atom meas.
1993PA14	Relativistic mean field theory; calc. binding energy, rms radii, deformation parameters
1993PA19	Continuation of 1993PA14: effects of pairing correlation

(A) denotes that only an abstract is available for this reference.

2. (a)  $^{10}\text{B}(^9\text{Be}, \text{p})^{18}\text{O}$   $Q_m = 16.892$   
 (b)  $^{11}\text{B}(^9\text{Be}, \text{d})^{18}\text{O}$   $Q_m = 7.662$

See (1986CU02) for production cross sections of 1.98 MeV  $\gamma$ -rays.

3.  $^{12}\text{C}(^7\text{Li}, \text{p})^{18}\text{O}$   $Q_m = 8.401$

Observed proton groups are displayed in Table 18.5 of (1987AJ02). See also (1983AJ01).

In a recent experiment, the  $4^+$  state at 7117 keV in  $^{18}\text{O}$  was studied by (1994ME02) and an E2 strength for the 7117–5060 branches of  $B(E2) = 6.4 \pm 1.6$  W.u. was deduced in agreement with results of (1989GA01). It was concluded that it is highly improbable that the 7117 keV state is energetically degenerate with a state of different decay properties.

4.  $^{13}\text{C}(^6\text{Li}, \text{p})^{18}\text{O}$   $Q_m = 10.704$

See (1986SM01) and Table 18.5 in (1987AJ02). It is noted there that existing data indicate that when  $\sigma_{\text{tot}}$  to a particular state in  $^{18}\text{O}$  is large in this reaction, it is also large in the  $^{12}\text{C}(^7\text{Li}, \text{p})$  reaction. More recent data are reported in (1988SM01) (see Table 18.11 here). Differential cross sections were measured and compared with results of Hauser-Feshbach calculations. The results suggest the presence of an additional non-statistical mechanism.

Table 18.9: Energy levels of  $^{18}\text{O}$  <sup>a</sup>

$E_x$ (MeV $\pm$ keV)	$J^\pi; T$	$\tau^b$ or $\Gamma_{\text{c.m.}}$	Decay	Reactions
0	$0^+; 1$		stable	2, 3, 4, 5, 6, 7, 8, 9, 10, 11, 12, 15, 19, 20, 21, 22, 23, 24, 25, 26, 27, 28, 29, 30, 31, 32, 33, 34, 35, 36, 37, 39, 40, 41, 42, 43, 44, 45, 46, 47, 48, 49, 50, 51, 52
$1.98207 \pm 0.09$	$2^+$	$\tau_m = 2.80 \pm 0.07$ ps ( $g = -0.287 \pm 0.015$ ) ( $Q = -0.042 \pm 0.008$ b)	$\gamma$	1, 2, 3, 4, 5, 6, 7, 8, 9, 10, 11, 15, 17, 19, 20, 21, 22, 25, 26, 27, 28, 29, 30, 32, 33, 39, 40, 42, 44, 45, 47, 48, 49, 50, 51, 52
$3.55484 \pm 0.40$	$4^+$	$\tau_m = 24.8 \pm 1.2$ ps ( $g = -0.62 \pm 0.10$ )	$\gamma$	3, 4, 7, 9, 10, 15, 16, 17, 19, 20, 21, 22, 25, 28, 33, 39, 40, 51, 52
$3.63376 \pm 0.11$	$0^+$	$\tau_m = 1.38 \pm 0.16$ ps	$\gamma$	3, 4, 7, 9, 10, 15, 19, 22, 25, 28, 33, 39, 40, 50, 51, 52
$3.92044 \pm 0.14$	$2^+$	$\tau_m = 26.5 \pm 2.9$ fs	$\gamma$	3, 4, 7, 9, 10, 15, 19, 22, 25, 28, 33, 39, 51
$4.45554 \pm 0.10$	$1^-$	$\tau_m = 65 \pm 15$ fs	$\gamma$	3, 4, 7, 9, 10, 15, 19, 22, 25, 28, 33, 39, 40, 50, 51
$5.09778 \pm 0.54$	$3^-$	$\tau_m = 62 \pm 25$ fs	$\gamma$	3, 4, 7, 9, 10, 15, 19, 22, 25, 26, 27, 28, 33, 39, 40, 45, 51, 52
$5.2548 \pm 0.9$	$2^+$	$\tau_m = 10.1 \pm 0.5$ fs	$\gamma$	3, 4, 7, 9, 10, 15, 17, 19, 25, 28, 33, 50, 51
$5.3364 \pm 0.6$	$0^+$	$\tau_m = 200 \pm 40$ fs	$\gamma$	3, 4, 9, 15, 19, 25, 33, 51
$5.3778 \pm 1.2$	$3^+$	$\tau_m < 30$ fs	$\gamma$	3, 4, 15, 19, 20, 51
$5.53024 \pm 0.29$	$2^-$	$\tau_m < 25$ fs $\Gamma < 50$ keV	$\gamma$	3, 4, 15, 22, 25, 28, 33, 51
$6.19822 \pm 0.40$	$1^-$	$\tau_m = 3.7 \pm 0.6$ fs	$\gamma$	3, 4, 9, 15, 19, 22, 24, 25, 33, 51
$6.3513 \pm 0.6$	$(2^-)$	$\tau_m < 35$ fs $\Gamma < 50$ keV	$\gamma$	3, 4, 15, 19, 22, 25, 33, 51, 52

Table 18.9: Energy levels of  $^{18}\text{O}$  <sup>a</sup> (continued)

$E_x$ (MeV $\pm$ keV)	$J^\pi; T$	$\tau^b$ or $\Gamma_{\text{c.m.}}$	Decay	Reactions
6.4044 $\pm$ 1.2	$3^-$	$\tau_m = 30 \pm 15$ fs	$\gamma$	3, 4, 15, 33, 51
6.88045 $\pm$ 0.27	$0^-$	$\tau_m < 25$ fs	$\gamma$	3, 4, 15, 22, 33, 50, 51
7.1169 $\pm$ 1.2	$4^+$	$\tau_m < 25$ fs	$\gamma, \alpha$	3, 4, 7, 9, 10, 15, 17, 19, 20, 25, 28, 33, 37, 39, 40, 51
7.6159 $\pm$ 0.7	$1^-$	$\Gamma < 2.5$ keV	$\gamma, \alpha$	3, 4, 7, 9, 15, 22, 25, 33, 37, 39, 40, 51
7.77107 $\pm$ 0.50	$2^-$	$\Gamma < 50$ keV	$\gamma$	3, 4, 15, 22, 25, 51
7.864 $\pm$ 5	$5^-$		$\gamma$	3, 4, 7, 9, 10, 15, 19, 20, 25, 33, 37, 39, 40, 51, 52
7.977 $\pm$ 4	$(3^+, 4^-)$		$\gamma$	3, 4, 15, 19, 51
8.0378 $\pm$ 0.7	$1^-$	$\Gamma < 2.5$ keV	$\gamma, \alpha$	3, 4, 7, 8, 15, 16, 17, 22, 25, 37, 39, 40, 51
8.125 $\pm$ 2	$5^-$		$\gamma, \alpha$	3, 4, 7, 9, 10, 15, 25, 51
8.213 $\pm$ 4	$2^+$	$\Gamma = 1.0 \pm 0.8$ keV	$\gamma, n, \alpha$	3, 4, 7, 8, 15, 25, 28, 33, 37, 39, 40, 51
8.282 $\pm$ 3	$3^-$	$\Gamma = 8 \pm 1$ keV	$\gamma, n, \alpha$	3, 4, 7, 8, 9, 10, 15, 25, 33, 51
8.410 $\pm$ 8	$(2^-)$	$\Gamma = 8 \pm 6$ keV	$\gamma, n, \alpha$	8, 15, 25, 51
8.521 $\pm$ 6	$(4^-)$	$\Gamma < 50$ keV	$\gamma$	15, 25, 51
8.660 $\pm$ 6				15, 51
8.817 $\pm$ 12	$(1^+)$	$\Gamma = 70 \pm 12$ keV	$n, \alpha$	8, 20, 28, 33
8.955 $\pm$ 4	$(4^+)$	$\Gamma = 43 \pm 3$ keV	$\gamma, n, \alpha$	8, 15, 25, 33
(9.0 $\pm$ 200) <sup>d</sup>	$(1^-)$		$\alpha$	22
9.03				15, 19, 33
(9.10)				33
9.27 $\pm$ 20 <sup>d</sup>	$(0, 1, 2)^-$		$n$	22
9.361 $\pm$ 6	$2^+$	$\Gamma = 27 \pm 15$ keV	$\gamma, n, \alpha$	8, 10, 15, 25, 33, 37, 39, 40
9.414 $\pm$ 18		$\Gamma \approx 120$ keV	$n, \alpha$	8, 10, 15, 33
9.48 $\pm$ 24		$\Gamma \approx 65$ keV	$n, \alpha$	8, 15
9.672 $\pm$ 7	$(3^-)$	$\Gamma = 60 \pm 30$ keV	$n, \alpha$	8, 15, 33, 37, 39, 40
9.713 $\pm$ 7	$(5^-)$	$\Gamma < 50$ keV	$\gamma$	15, 25, 33
9.890 $\pm$ 11		$\Gamma \approx 150$ keV	$n, \alpha$	8, 15, 33

Table 18.9: Energy levels of  $^{18}\text{O}$  <sup>a</sup> (continued)

$E_x$ (MeV $\pm$ keV)	$J^\pi; T$	$\tau^b$ or $\Gamma_{\text{c.m.}}$	Decay	Reactions
10.118 $\pm$ 10	$3^-$	$\Gamma = 16 \pm 4$ keV	n, $\alpha$	8, 9, 15, 33
10.24 $\pm$ 20 <sup>d</sup>	$(0, 1, 2)^-$		n	22
10.295 $\pm$ 14	$4^+$	$\Gamma < 50$ keV	$\gamma$ , n, $\alpha$	8, 9, 10, 15, 16, 25, 33, 37, 39, 40
10.396 $\pm$ 9	$3^-$		n, $\alpha$	8, 15, 33
10.43 $\pm$ 40	$(2^-)$	$\Gamma < 50$ keV	$\gamma$	25
10.595 $\pm$ 15			n, $\alpha$	8, 15
10.67 $\pm$ 20	$(2^-)$	$\Gamma < 50$ keV	$\gamma$	25
10.82 $\pm$ 20			n, $\alpha$	8
10.91 $\pm$ 20			n, $\alpha$	8, 10
10.99 $\pm$ 20	$(2^-)$	$\Gamma < 50$ keV	$\gamma$ , n, $\alpha$	8, 25
11.06	$(6^-)$			20
11.13 $\pm$ 20			n, $\alpha$	8, 10, 50
11.39 $\pm$ 20	$(2^+)$		n, $\alpha$	8, 9
11.41 $\pm$ 20	$(4^+)$		n, $\alpha$	8, 9
11.49 $\pm$ 30 <sup>d</sup>	$(0, 1, 2)^-$		n	22
11.52 $\pm$ 50	$(2^-)$	$\Gamma < 50$ keV	$\gamma$	25
11.62 $\pm$ 20	$5^-$		n, $\alpha$	8, 9, 10, 33, 37, 39, 40
11.67 $\pm$ 20	$(3^-)$	$\Gamma = 112 \pm 0.02$ keV		25
11.69 $\pm$ 20	$6^+$		n, $\alpha$	8, 9, 10, 33
11.82 $\pm$ 20	$(3^-)$		n, $\alpha$	8
11.90 $\pm$ 30	$(2^-)$	$\Gamma < 50$ keV	$\gamma$	25
12.04 $\pm$ 20	$(2^+)$		n, $\alpha$	8, 9
12.09 $\pm$ 20	$(1^-, 2^+)$	$\Gamma < 50$ keV		25
12.25 $\pm$ 20	$(1^-)$		n, $\alpha$	8, 9
12.33 $\pm$ 20	$5^-$		n, $\alpha$	8, 9, 10
12.41 $\pm$ 20	$(3^-)$	$\Gamma = 143 \pm 24$ keV	$\gamma$	25
12.50 $\pm$ 20	$4^+$		n, $\alpha$	8, 37, 39, 40
12.52 $\pm$ 20		$\Gamma < 50$ keV	$\gamma$	25
12.53 $\pm$ 20	$6^+$		n, $\alpha$	8, 9, 10, 37, 39, 40

Table 18.9: Energy levels of  $^{18}\text{O}$  <sup>a</sup> (continued)

$E_x$ (MeV $\pm$ keV)	$J^\pi; T$	$\tau^b$ or $\Gamma_{\text{c.m.}}$	Decay	Reactions
12.66 $\pm$ 20	(2 <sup>-</sup> )	$\Gamma < 50$ keV	$\gamma$	25
12.99 $\pm$ 20	(4 <sup>-</sup> )	$\Gamma = 68 \pm 18$ keV	$\gamma$	25
13.1 <sup>c</sup>	1 <sup>-</sup>	$\Gamma = 700$ keV	$\gamma, n$	23
13.40 $\pm$ 20	(2 <sup>-</sup> )	$\Gamma = 108 \pm 20$ keV	$\gamma$	25
13.8	1 <sup>-</sup>	$\Gamma = 600$ keV	$\gamma, n$	23
13.85 $\pm$ 13	(6 <sup>-</sup> )	$\Gamma \approx 200$ keV	$\gamma$	20, 25
14.17 $\pm$ 40	(6 <sup>-</sup> )	$\Gamma = 140 \pm 50$ keV	$\gamma$	20, 25
14.45 $\pm$ 50		$\Gamma \approx 1070$ keV	$\gamma$	25
14.7	1 <sup>-</sup>	$\Gamma = 800$ keV	$\gamma, n$	23
15.23 $\pm$ 40		$\Gamma \approx 300$ keV	$\gamma$	25
15.8	1 <sup>-</sup>	$\Gamma = 700$ keV	$\gamma, n$	23
15.95 $\pm$ 30		$\Gamma < 50$ keV	$\gamma$	25
16.210 $\pm$ 10	1 <sup>(-)</sup>		$\gamma$	25
16.315 $\pm$ 10	(3, 2) <sup>-</sup>		$\gamma$	25
16.399 $\pm$ 5	2 <sup>-</sup> ; 2	$\Gamma < 20$ keV	$\gamma$	25, 28
16.88 $\pm$ 30	(4 <sup>-</sup> , 2 <sup>-</sup> ); (1)	$\Gamma < 50$ keV	$\gamma$	25
16.948 $\pm$ 10	(3, 2) <sup>-</sup>		$\gamma$	25
17.025 $\pm$ 10	(3 <sup>-</sup> ); 2	$\Gamma = 20 \pm 6$ keV	$\gamma$	25
17.05	(7 <sup>-</sup> )	$\Gamma \approx 350$ keV		9
17.398 $\pm$ 10	1 <sup>-</sup> ; (2)	$\Gamma = 600$ keV	$\gamma, n, p$	23, 25
17.450 $\pm$ 10	(2, 1, 3) <sup>-</sup>		$\gamma$	25
17.46 $\pm$ 30	(4 <sup>-</sup> ); 1	$\Gamma \approx 600$ keV	$\gamma$	25
17.5		$\Gamma \approx 150$ keV	$\gamma$	25
17.502 $\pm$ 10	(1, 2, 3) <sup>-</sup>		$\gamma$	25
(17.6 $\pm$ 200)	(8 <sup>+</sup> )			9
17.635 $\pm$ 10			$\gamma$	25
18.049 $\pm$ 10			$\gamma$	25
18.2		$\Gamma \approx 150$ keV	$\gamma$	25
18.45 $\pm$ 20	(3 <sup>-</sup> ); (1)	$\Gamma = 75 \pm 27$ keV	$\gamma$	25
18.5		$\Gamma \approx 4300$ keV	$\gamma$	25

Table 18.9: Energy levels of  $^{18}\text{O}$  <sup>a</sup> (continued)

$E_x$ (MeV $\pm$ keV)	$J^\pi; T$	$\tau$ <sup>b</sup> or $\Gamma_{\text{c.m.}}$	Decay	Reactions
18.70 $\pm$ 20	(4 <sup>-</sup> ); 2	$\Gamma < 20$ keV	$\gamma$	25
18.871 $\pm$ 5	1 <sup>+</sup> ; 2		$\gamma$	25
18.927 $\pm$ 10	(1, 2 <sup>+</sup> )		$\gamma$	25
18.95	(7 <sup>-</sup> )	$\Gamma \approx 350$ keV		9
19.027 $\pm$ 10	(1, 3) <sup>-</sup>		$\gamma$	25
19.150 $\pm$ 10	(1 <sup>-</sup> , 2 <sup>+</sup> , 3 <sup>-</sup> )		$\gamma$	25
19.24 $\pm$ 20	(> 2); 2	$\Gamma < 20$ keV	$\gamma$	25
19.4	1 <sup>-</sup> ; (2)	$\Gamma = 900$ keV	$\gamma, \text{p}$	23
19.7		$\Gamma \approx 200$ keV	$\gamma$	25
20.2		$\Gamma \approx 180$ keV	$\gamma$	25
20.36 $\pm$ 20	(4 <sup>-</sup> ); 2	$\Gamma < 20$ keV	$\gamma$	25
20.86 $\pm$ 20		$\Gamma = 97 \pm 41$ keV	$\gamma$	25
21.0	1 <sup>-</sup> ; (1)	$\Gamma \approx 150$ keV	$\gamma, \text{n}, \text{p}$	23, 25
21.42 $\pm$ 20	(4 <sup>-</sup> ); (2)	$\Gamma < 50$ keV	$\gamma$	25
22.40 $\pm$ 20	4 <sup>-</sup> ; 2	$\Gamma = 91 \pm 8$ keV	$\gamma$	25
22.7	1 <sup>-</sup>		$\gamma, \text{n}, \text{p}$	23
23.10 $\pm$ 20		$\Gamma = 49 \pm 24$ keV	$\gamma$	25
23.8	1 <sup>-</sup> ; (1)	$\Gamma \approx 1500$ keV	$\gamma, \text{n}, \text{p}$	23, 25
27	1 <sup>-</sup> ; (2)		$\gamma, \text{n}, \text{p}$	23
30			$\gamma, \text{n}$	23
36			$\gamma$	23

<sup>a</sup> See also Tables 18.10 and 18.21 here and 18.12 in (1983AJ01).

<sup>b</sup> See Table 18.14 in (1978AJ03) for a display of  $\tau_{\text{m}}$  measurements.

<sup>c</sup> For additional states with  $12.9 \leq E_x \leq 23.1$  MeV see (1983CU03) [reaction 9].

<sup>c</sup> See reaction 22 in  $^{18}\text{O}$  and Table 18.18 for discussion of this level.

5.  $^{13}\text{C}(^9\text{Be}, \alpha)^{18}\text{O}$

$$Q_{\text{m}} = 12.830$$

See (1983AJ01, 1987AJ02).



6.  $^{13}\text{C}(^{17}\text{O}, ^{12}\text{C})^{18}\text{O}$

$$Q_m = 3.098$$

See (1983AJ01, 1987AJ02).

7.  $^{14}\text{C}(\alpha, \gamma)^{18}\text{O}$

$$Q_m = 6.227$$

Table 18.10: Radiative decays in  $^{18}\text{O}$  <sup>a</sup>

$E_i$ (MeV)	$J_i^\pi$	$E_f$ (MeV)	Branch (%)	$\delta$
1.98	$2^+$	0	100	
3.55	$4^+$	1.98	100	
3.63	$0^+$	0	$0.30 \pm 0.06$ <sup>b</sup>	
		1.98	$99.70 \pm 0.06$	
3.92	$2^+$	0	$12.4 \pm 0.7$	
		1.98	$87.6 \pm 0.7$	c
4.46	$1^-$	1.98	$27.1 \pm 2.6$	c
		3.63	$70.4 \pm 1.7$	
		3.92	$2.5 \pm 0.9$	
5.10	$3^-$	1.98	$76.1 \pm 0.8$	c
		3.55	$6.3 \pm 0.8$	c
		3.92	$17.6 \pm 0.7$	c
5.26	$2^+$	0	$30.3 \pm 0.9$	
		1.98	$55.9 \pm 1.0$	$0.15 \pm 0.04$
		3.55	$1.1 \pm 0.6$	
		3.63	$1.0 \pm 0.6$	
		3.92	$8.7 \pm 0.4$	
		4.46	$3.0 \pm 0.3$	
5.34	$0^+$	0	<sup>d</sup>	
		1.98	$58 \pm 2$	
		4.46	$42 \pm 2$	
5.38	$3^+$	1.98	$86.5 \pm 2.2$	c
		3.92	$13.5 \pm 2.2$	c
5.53	$2^-$	1.98	$49 \pm 2$	c

Table 18.10: Radiative decays in  $^{18}\text{O}$  <sup>a</sup> (continued)

$E_i$ (MeV)	$J_i^\pi$	$E_f$ (MeV)	Branch (%)	$\delta$
6.20	$1^-$	3.92	$24 \pm 2$	c
		4.46	$27 \pm 2$	
		0	$88.7 \pm 0.9$	
		3.63	$2.5 \pm 0.3$	
		4.46	$4.1 \pm 0.4$	
		5.26	$3.6 \pm 0.4$	
6.35	$(2^-)$	5.34	$1.1 \pm 0.3$	c
		1.98	$32 \pm 2$	
		3.92	$55 \pm 2$	
6.40	$3^-$	4.46	$12 \pm 2$	c
		1.98	$68.1 \pm 1.8$	
		3.55	$7.4 \pm 1.2$	
		3.92	$6.3 \pm 1.0$	
		4.46	$2.8 \pm 1.0$	
		5.10	$9.8 \pm 0.9$	
		5.26	$5.6 \pm 0.9$	
		4.46	100	
6.88	$0^-$	4.46	100	c
7.12 <sup>c</sup>	$4^+$	1.98	$27.1 \pm 0.4$	$-(0.052 \pm 0.035)$
		3.55	$69.2 \pm 0.7$	
		3.92	$2.1 \pm 0.2$	
		5.10	$1.3 \pm 0.2$	
		5.26	$0.30 \pm 0.06$	
		7.62	$1^-$	
1.98	$62 \pm 3^f$			
4.46	$8 \pm 1$			
5.34	$6 \pm 1$			
6.20	$1 \pm 1$			
7.77	$2^-$	1.98	$53 \pm 3$	
		4.46	$11 \pm 2$	
		5.10	$36 \pm 3$	
7.86	$5^-$	3.55	$> 75$	

Table 18.10: Radiative decays in  $^{18}\text{O}$  <sup>a</sup> (continued)

$E_i$ (MeV)	$J_i^\pi$	$E_f$ (MeV)	Branch (%)	$\delta$
7.98	$(3^+, 4^-)$	3.55	$67 \pm 2$	
		5.10	$12 \pm 2$	
		5.38	$21 \pm 2$	
8.04	$1^-$	0	$16 \pm 1$	
		1.98	$70 \pm 2$ <sup>g</sup>	
		3.63	$10 \pm 1$	
		5.26	$4 \pm 1$	
8.13	$5^-$	3.55	$99 \pm 1$ <sup>h</sup>	
		5.10	$1 \pm 1$	
8.21	$2^+$	0	$19 \pm 4$	
		1.98	$29 \pm 3$	
		3.55	$3 \pm 1$	
		3.92	$3 \pm 1$	
		4.46	$29 \pm 3$	
		5.10	$17 \pm 1$	
		5.26	$36 \pm 3$	
8.28	$3^-$	3.55	$61 \pm 3$	
		4.46	$3 \pm 3$	
		5.26	$36 \pm 3$	

<sup>a</sup> For references and additional information see Tables 18.3 in (1978AJ03, 1983AJ01).

Upper limits for other transitions are not shown.

<sup>b</sup>  $\Gamma_\pi/\Gamma = (3.0 \pm 0.6) \times 10^{-3}$  (1975SO05).

<sup>c</sup>  $\delta$  is consistent with 0.

<sup>d</sup>  $\Gamma_\pi/\Gamma \leq 2.3 \times 10^{-3}$ .

<sup>e</sup>  $\Gamma_\gamma/\Gamma = 0.561 \pm 0.013$  (1994ME02)

<sup>f</sup>  $\Gamma_\alpha\Gamma_\gamma/\Gamma = 0.34$  eV.

<sup>g</sup>  $\Gamma_\alpha\Gamma_\gamma/\Gamma = 0.89$  eV.

<sup>h</sup>  $\Gamma_\alpha\Gamma_\gamma/\Gamma = 0.22$  eV.

Table 18.11: States of  $^{18}\text{O}$  from  $^{13}\text{C}(^6\text{Li}, \text{p})$  <sup>a</sup>

$E_x$ <sup>a</sup> (MeV $\pm$ keV)	$\sigma_{\text{tot}}$ <sup>a,b</sup> ( $\mu\text{b}$ )	$E_x$ <sup>a</sup> (MeV $\pm$ keV)	$\sigma_{\text{max}}$ <sup>a</sup> ( $\mu\text{b}/\text{sr}$ )
0	$6.1 \pm 0.3$	$8.667 \pm 13$	$20.8 \pm 1.0$
$1.987 \pm 8$	$39 \pm 1$	$8.82 \pm 20$	$13.0 \pm 0.9$
$3.555 \pm 10$	$56 \pm 1$	$8.96 \pm 20$	$16.3 \pm 1.0$
$3.632 \pm 15$	$13 \pm 1$	$9.72 \pm 30$	$26.3 \pm 1.3$
$3.926 \pm 6$	$36 \pm 1$	$10.09 \pm 30$	$30.6 \pm 1.5$
$4.455 \pm 8$	$46 \pm 1$	$10.28 \pm 30$	$100 \pm 5$
$5.095 \pm 11$	$74 \pm 1$	$10.63 \pm 30$	$31.3 \pm 1.6$
$5.256 \pm 9$	$44 \pm 1$	$10.90 \pm 30$	$42.7 \pm 2.1$
$5.374 \pm 8$	$35 \pm 1$	$10.99 \pm 20$	$84.8 \pm 4.2$
$5.532 \pm 8$	$45 \pm 1$	$11.12 \pm 20$	$17.7 \pm 0.9$
$6.199 \pm 8$	$37 \pm 1$	$11.26 \pm 20$	$33.9 \pm 1.7$
$6.383 \pm 11$ <sup>c</sup>	$131 \pm 2$	$11.42 \pm 30$	$46.6 \pm 2.3$
$6.882 \pm 19$	$5.3 \pm 0.4$	$11.61 \pm 30$	$34.1 \pm 1.7$
$7.117 \pm 5$ <sup>d</sup>	$208 \pm 2$	$11.70 \pm 30$	$75.4 \pm 3.8$
$7.618 \pm 10$	$33 \pm 1$	$11.85 \pm 30$	$81.9 \pm 4.1$
$7.764 \pm 14$	$37 \pm 1$	$12.07 \pm 30$	$34.2 \pm 1.7$
$7.850 \pm 13$	$101 \pm 1$	$12.23 \pm 30$	$32.1 \pm 1.6$
$7.962 \pm 12$	$84 \pm 1$	$12.33 \pm 30$	$50.4 \pm 2.5$
$8.026 \pm 14$	$19 \pm 1$	$12.44 \pm 30$	$96.0 \pm 4.8$
$8.120 \pm 12$	$140 \pm 2$	$12.54 \pm 30$	$90.2 \pm 4.5$
$8.200 \pm 17$	$48 \pm 1$	$13.08 \pm 30$	$48.4 \pm 2.4$
$8.274 \pm 15$	$103 \pm 2$	$13.23 \pm 30$	$99.3 \pm 5.0$
$8.401 \pm 12$	$45 \pm 1$	$13.48 \pm 30$	$24.6 \pm 1.2$
$8.496 \pm 15$	$75 \pm 1$	$13.60 \pm 30$	$29.0 \pm 1.5$
		$13.81 \pm 30$	$159 \pm 8$
		$14.14 \pm 30$	$92.7 \pm 4.6$
		$15.80 \pm 30$	$136 \pm 7$

<sup>a</sup> (1988SM01). The maximum value of the differential cross section results were compared with a Hauser-Feshbach calculation. The comparison suggests the the presence of an additional nonstatistical mechanism.

<sup>b</sup> See Table 18.5 in (1987AJ02), which shows a comparison with  $\sigma_{\text{tot}}$  from  $^{12}\text{C}(^7\text{Li}, \text{p})$  for  $E_x \leq 8.3$  MeV.

<sup>c</sup> Unresolved doublet (1988SM01).

<sup>d</sup> See discussion of  $\Gamma_\gamma/\Gamma$  results from (1994ME02) under reaction 3 here.

Table 18.12: Resonances in  $^{14}\text{C}(\alpha, \gamma)^{18}\text{O}$ ,  $^{14}\text{C}(\alpha, n)^{17}\text{O}$  and  $^{14}\text{C}(\alpha, \alpha)^{14}\text{C}$  <sup>a</sup>

$E_\alpha$ (MeV $\pm$ keV)	$\Gamma_{\text{lab}}$ (keV)	Particles out	$E_x(^{18}\text{O})$ (MeV)	$J^\pi$
1.140 $\pm$ 2 <sup>b</sup>		$\gamma$	7.114	4 <sup>+</sup>
1.790 $\pm$ 2 <sup>b</sup>	< 3	$\gamma$	7.619 <sup>h</sup>	1 <sup>-</sup>
2.10 <sup>b</sup>		$\gamma$	7.86	5 <sup>-</sup>
2.330 $\pm$ 2 <sup>b</sup>	< 3	$\gamma, \alpha_0$	8.039 <sup>b, h</sup>	1 <sup>-</sup>
2.440 $\pm$ 2 <sup>b</sup>		$\gamma$	8.125	5 <sup>-</sup>
2.554 $\pm$ 4 <sup>b</sup>	1.3 $\pm$ 1	$\gamma, n, \alpha_0$	8.213	2 <sup>+</sup>
2.643 $\pm$ 3 <sup>b</sup>	10 $\pm$ 1	$\gamma, n, \alpha_0$	8.282	3 <sup>-</sup>
2.800 $\pm$ 7	10 $\pm$ 7	n	8.404	
3.330 $\pm$ 12	90 $\pm$ 15	n, $\alpha_0$	8.817	
3.508 $\pm$ 4	55 $\pm$ 3	n, $\alpha_0$	8.955	
4.030 $\pm$ 15	35 $\pm$ 20	n, ( $\alpha_0$ )	9.361	
4.07 $\pm$ 40	$\approx$ 150	n, ( $\alpha_0$ )	9.39	
4.17 $\pm$ 40	$\approx$ 70	n, ( $\alpha_0$ )	9.47	
4.434 $\pm$ 10	80 $\pm$ 40	n, ( $\alpha_0$ )	9.675	
4.70 $\pm$ 40	$\approx$ 200	n, ( $\alpha_0$ )	9.88	
5.004 $\pm$ 10	21 $\pm$ 5	n, $\alpha_0$	10.118	3 <sup>-</sup>
5.23 <sup>c</sup>	d	n, $\alpha_0$	10.29	4 <sup>+</sup>
5.34	d	n, $\alpha_0$	10.38	3 <sup>-</sup>
5.60	e	n, $\alpha_0$	10.58	
5.90	f	n, $\alpha_0$	10.82	
6.02	f	n, $\alpha_0$	10.91	
6.13	f	n, $\alpha_0$	10.99	
6.30	e	n, $\alpha_0$	11.13	
6.64	d	n, $\alpha_0$	11.39	(2 <sup>+</sup> )
6.67	d	n, $\alpha_0$	11.41	(4 <sup>+</sup> )
6.93	d	n, $\alpha_0$	11.62	5 <sup>-</sup>
7.03	d	n, $\alpha_0$	11.69	6 <sup>+</sup>
7.19	f	n, $\alpha_0$	11.82	(3 <sup>-</sup> )
7.47	f	n, $\alpha_0$	12.04	(2 <sup>+</sup> )
7.75	g	n, $\alpha_0$	12.25	(0 <sup>+</sup> , 1 <sup>-</sup> )
7.85	d	n, $\alpha_0$	12.33	5 <sup>-</sup>
8.06	d	n, $\alpha_0$	12.50	4 <sup>+</sup>
8.10	d	n, $\alpha_0$	12.53	6 <sup>+</sup>

<sup>a</sup> See also Table 18.11. For references see Table 18.5 in (1978AJ03).

<sup>b</sup> (1987GA15):  $\Gamma_\gamma = 0.095 \pm 0.020, 0.41 \pm 0.08, 0.043 \pm 0.009, 1.07 \pm 0.22, 0.27 \pm 0.05, 0.41 \pm 0.09,$  and  $0.49 \pm 0.13$  eV, respectively for  $^{18}\text{O}^*(7.11, 7.62, 7.86, 8.04, 8.13, 8.21, 8.28 \text{ MeV})$ .

<sup>c</sup>  $\pm 10 - 20$  keV for this and all higher resonances (G.E. Mitchell, private communication).

<sup>d</sup>  $\Gamma_\alpha$ , large;  $\Gamma_n$ , large.

<sup>e</sup>  $\Gamma_\alpha$ , small;  $\Gamma_n$ , small.

<sup>f</sup>  $\Gamma_\alpha$ , small;  $\Gamma_n$ , large.

<sup>g</sup>  $\Gamma_\alpha$ , large;  $\Gamma_n$ , small.

<sup>h</sup> Recent  $^{14}\text{C}(\alpha, \gamma)$  measurements for these two  $1^-$  states by (1994HA17) gave  $E_x = 7.6159 \pm 0.0007$  and  $8.0378 \pm 0.0007$  keV.

Resonances in the yield of capture  $\gamma$ -rays are observed at  $E_\alpha = 1.14, 1.79, 2.09, 2.33, 2.44, 2.55,$  and  $2.64$  MeV: see Tables 18.12 here and 18.5 in (1978AJ03). Gamma-ray angular distribution and correlation measurements lead to  $J^\pi = 4^+, 1^-, 1^-,$  and  $5^-$  for  $^{18}\text{O}^*(7.11, 7.62, 8.04, 8.13)$ , as well as to  $J^\pi$  assignments for lower states involved in the cascade decay. See also references in (1987AJ02) and see the cross section measurements of (1993DA17). The speculated presence of enhanced E1  $\gamma$  de-excitation in  $^{18}\text{O}$  (1983GA02) was followed by further experimental and theoretical investigations of collective band structure in  $^{18}\text{O}$  (1989FU08, 1993RE03). See however (1986HA1J). See also (1989FU1H, 1989KAZH). The  $4_2^+ \rightarrow 2_2^+$  (7117  $\rightarrow$  5260) keV  $\gamma$  branching ratio of  $0.30 \pm 0.08\%$  was measured by (1989GA01) and an E2 transition strength  $B(\text{E2}) = 5.7 \pm 1.9$  W.u. was deduced. This result is conformed by the  $(\Gamma_{\alpha X} \Gamma_\gamma)/(\Gamma_\alpha + \Gamma_\gamma)$  and (7117  $\rightarrow$  5260) keV  $\gamma$  branching ( $0.24 \pm 0.08\%$ ) measurements of (1992GO14) and the  $\Gamma_\gamma/\Gamma_\alpha$  measurement of (1994ME02).

The  $^{14}\text{C}(\alpha, \gamma)$  reaction is important in astrophysical processes and the details of the cross section are relevant to the process of heavy element formation in inhomogeneous big bang nucleosynthesis (1988AP1A, 1989FU06, 1990WIZP, 1992GA11, 1992GO14). See also (1988BU01, 1988MA1U, 1989KA1K, 1989NO1A, 1989TH1C) and the review of thermonuclear reaction rates in (1988CA26).

8. (a)  $^{14}\text{C}(\alpha, \alpha')^{14}\text{C}$

$$E_b = 6.227$$

(b)  $^{14}\text{C}(\alpha, n)^{17}\text{O}$

$$Q_m = -1.817$$

Observed anomalies in the scattering [reaction (a)] for  $E_\alpha = 2$  to  $8.2$  MeV and the resonances in the relative neutron yield [reaction (b)] for  $E_\alpha = 2.3$  MeV are displayed in Table 18.12. See also (1978AJ03).

The  $\alpha$ -cluster structure of  $^{18}\text{O}$  has been investigated in theoretical work of (1989FU08, 1993RE03) based on  $^{14}\text{C}(\alpha, \alpha)$  scattering, and the results do not support the existence of proposed negative-parity molecular dipole states. See (1989GA01).

9. (a)  $^{14}\text{C}(^6\text{Li}, \text{d})^{18}\text{O}$

$$Q_m = 4.752$$

(b)  $^{14}\text{C}(^6\text{Li}, \text{d}\alpha)^{14}\text{C}$

$$Q_m = -1.475$$

Table 18.13: Gamma-ray branching ratios in  $^{14}\text{C}(\alpha, \gamma)^{18}\text{O}$  <sup>a</sup>

$E_i$ (MeV)	$J_i^\pi$	$E_f$ (MeV)	$J_f^\pi$	Branching ratio (%)
$7.620 \pm 0.002$	$1^-$	0	$0^+$	$23 \pm 2$
		1.98	$2^+$	$62 \pm 3$
		3.63	$0^+$	$< 1$
		3.92	$2^+$	$< 3$
		4.46	$1^-$	$8 \pm 2$
		5.26	$2^+$	$< 3$
		5.34	$0^+$	$6 \pm 1$
		5.53	$2^-$	$< 5$
		6.20	$1^-$	$1 \pm 1$
		$7.859 \pm 0.005$	$5^-$	3.56
$8.040 \pm 0.002$	$1^-$	0	$0^+$	$17 \pm 1$
		1.98	$2^+$	$71 \pm 2$
		3.63	$0^+$	$9 \pm 1$
		3.92	$2^+$	$< 1$
		4.46	$1^-$	$< 1.5$
		5.10	$3^-$	$< 1$
		5.26	$2^+$	$3.2 \pm 0.9$
		5.34	$0^+$	$< 1$
		5.53	$2^-$	$< 2$
		6.20	$1^-$	$< 2$
$8.125 \pm 0.002$	$5^-$	3.55	$4^+$	$99 \pm 1$
		5.10	$3^-$	$1 \pm 1$
		7.12	$4^+$	$< 2$
$8.214 \pm 0.004$	$2^+$	0	$0^+$	$19 \pm 4$
		1.98	$2^+$	$29 \pm 3$
		3.55	$4^+$	$3 \pm 1$
		3.63	$0^+$	$< 3$

Table 18.13: Gamma-ray branching ratios in  $^{14}\text{C}(\alpha, \gamma)^{18}\text{O}$  <sup>a</sup> (continued)

$E_i$ (MeV)	$J_i^\pi$	$E_f$ (MeV)	$J_f^\pi$	Branching ratio (%)
$8.283 \pm 0.003$	$3^-$	3.92	$2^+$	$3 \pm 1$
		4.46	$1^-$	$29 \pm 3$
		5.10	$3^-$	$17 \pm 1$
		5.26	$2^+$	$< 3$
		5.34 – 6.35		$< 1$
		0	$0^+$	$< 7$
		1.98	$2^+$	$< 3$
		3.55	$4^+$	$61 \pm 3$
		3.92	$2^+$	$< 3$
		4.46	$1^-$	$3 \pm 3$
		5.10	$3^-$	$< 8$
		5.26	$2^+$	$36 \pm 3$
		5.38	$3^+$	$< 4$
5.53	$2^-$	$< 8$		
6.40	$3^-$	$< 5$		

<sup>a</sup> (1987GA15). See also Table 18.12 for measured  $\Gamma_\gamma$  for these levels.

At  $E(^6\text{Li}) = 34$  MeV angular distributions have been measured for the deuteron groups to many states of  $^{18}\text{O}$  (1981CU07) [see also (1983AJ01)] including  $^{18}\text{O}^*(17.6 \pm 0.2)$  (1982CU01).  $J^\pi = 4^+, 2^+, 2^+, (4^+)$ , and  $(4^+)$  are suggested for  $^{18}\text{O}^*(7.86, 8.9, 12.04, 14.6, 17.0)$  (1981CU07). The  $2^+, 4^+, 6^+$  and  $8^+$  members of the  $K^\pi = 0_2^+$  rotational band based on  $^{18}\text{O}^*(3.62)$  are  $^{18}\text{O}^*(5.26, 7.12, 11.69, 17.6)$  (1982CU01).

Angular correlations have been measured at  $E(^6\text{Li}) = 34$  MeV; these lead to the assignment of  $J^\pi = 8^+$  to  $^{18}\text{O}^*(17.6)$  (1982CU01) and to the assignment of  $J^\pi = 4^+, 5^-, 6^+, 7^-$  and  $8^+$  to sixteen states in  $^{18}\text{O}$  with  $11.4 \leq E_x \leq 23.1$  MeV (1983CU03) [see (1983CU03) for assignment of  $^{18}\text{O}$  states to bands]. At  $E(^6\text{Li}) = 32$  MeV (1983AR11) find that the strongest groups are those to (unresolved) structures at  $E_x = 17.05$  and  $18.95$  MeV [each  $\Gamma \approx 0.35$  MeV] dominated by  $J^\pi = 7^-$ .  $^{18}\text{O}^*(11.6, 12.6)$  with  $J^\pi = (6^+, 5^-)$  and  $5^-$  are also observed (1983AR11) [see, however, the density of states]. See also (1987AJ02, 1990OS03).

10.  $^{14}\text{C}(^7\text{Li}, t)^{18}\text{O}$

$Q_m = 3.760$



At  $E(^7\text{Li}) = 20.4$  MeV, triton groups are observed corresponding to a number of states of  $^{18}\text{O}$  with  $E_x < 12.6$  MeV. Angular distributions were obtained for some of these, including  $^{18}\text{O}^*(0, 1.98, 7.12, 11.69)$  with  $J^\pi = 0^+, 2^+, 4^+, 6^+$ . The latter two are the most strongly populated in this reaction: they appear to be part of the ground-state rotational band: see (1972AJ02). See also (1987AJ02).

In more recent work at  $E(^7\text{Li}) = 15$  MeV,  $^{18}\text{O}$  gamma de-excitation modes for all natural parity states up to the alpha-particle threshold at  $E_x = 6.227$  MeV were studied (1991GA08). See Table 18.14.

Table 18.14: Gamma decay branching ratios for  $^{18}\text{O}$  from  $^{14}\text{C}(^7\text{Li}, t\gamma)^{18}\text{O}$  <sup>a</sup>

$E_i$ (MeV)	$J_i^\pi$	$E_f$ (MeV)	$J_f^\pi$	Branching ratio (%)
1.98	$2_1^+$	0.00	$0^+$	100
3.55	$4_1^+$	1.98	$2^+$	100
3.63	$0_2^+$	1.98	$2^+$	100
3.92	$2_2^+$	0.00	$0^+$	$11.1 \pm 1.0$
		1.98	$2^+$	$88.9 \pm 1.0$
4.45	$1_1^-$	0.00	$0^+$	$< 0.2$
		1.98	$2^+$	$29.5 \pm 1.0$
		3.63	$0_2^+$	$68.9 \pm 1.0$
		3.92	$2_2^+$	$1.6 \pm 0.2$
5.10	$3_1^-$	1.98	$2^+$	$76.5 \pm 1.0$
		3.55	$4^+$	$5.6 \pm 1.0$
		3.92	$2_2^+$	$17.9 \pm 0.8$
		4.45	$1^-$	$< 0.14$
5.26	$2_3^+$	0.00	$0^+$	$30.3 \pm 0.9$
		1.98	$2^+$	$55.9 \pm 1.0$
		3.55	$4^+$	$1.1 \pm 0.6$
		3.63	$0_2^+$	$1.0 \pm 0.6$
		3.92	$2_2^+$	$8.7 \pm 0.4$
		4.45	$1^-$	$3.0 \pm 0.3$
5.34	$0_3^+$	1.98	$2^+$	$45.2 \pm 5.0$
		3.92	$2_2^+$	$< 12.0$
		4.45	$1^-$	$54.8 \pm 5.0$
6.20	$1_2^-$	0.00	$0^+$	$88.7 \pm 0.9$
		1.98	$2^+$	$< 1.3$

Table 18.14: Gamma decay branching ratios for  $^{18}\text{O}$  from  $^{14}\text{C}(^7\text{Li}, t\gamma)^{18}\text{O}$  <sup>a</sup>  
(continued)

$E_i$ (MeV)	$J_i^\pi$	$E_f$ (MeV)	$J_f^\pi$	Branching ratio (%)
6.40	$3_2^-$	3.63	$0_2^+$	$2.5 \pm 0.3$
		3.92	$2_2^+$	$< 0.9$
		4.45	$1^-$	$4.1 \pm 0.4$
		5.09	$3^-$	$< 0.7$
		5.26	$2_3^+$	$3.6 \pm 0.4$
		5.34	$0_3^+$	$1.1 \pm 0.3$
		1.98	$2^+$	$68.1 \pm 1.8$
		3.55	$4^+$	$7.4 \pm 1.2$
		3.92	$2_2^+$	$6.3 \pm 1.0$
		4.45	$1^-$	$2.8 \pm 1.0$
7.12	$4_2^+$	5.09	$3^-$	$9.8 \pm 0.9$
		5.26	$2_3^+$	$5.6 \pm 0.9$
		1.98	$2^+$	$27.0 \pm 0.5$
		3.55	$4^+$	$70.0 \pm 1.0$
		3.92	$2_2^+$	$1.8 \pm 0.4$
		5.09	$3^-$	$1.2 \pm 0.3$
		5.26	$2_3^+$	$< 0.6$
		6.40	$3_2^-$	$< 0.2$

<sup>a</sup> (1991GA08). See Table 1 of (1991GA08) for additional information including transition strengths. See also Table 18.10 here.

11.  $^{14}\text{C}(^{14}\text{C}, ^{10}\text{Be})^{18}\text{O}$   $Q_m = -5.785$

See (1985KO04).

12.  $^{14}\text{C}(^{16}\text{O}, ^{12}\text{C})^{18}\text{O}$   $Q_m = -0.935$

See (1978AJ03).

Table 18.15: States in  $^{18}\text{O}$  from  $^{16}\text{O}(t, p)$  <sup>a</sup>

$E_x$ (keV)	$L$	$J^\pi$	$E_x$ (keV)	$E_x$ (keV)
0	0	$0^+$	$7623 \pm 18$	$9713 \pm 7$
$1986 \pm 4$	2	$2^+$	$7782 \pm 6$	$9890 \pm 11$
$3556 \pm 2$	4	$4^+$	$7871 \pm 2^d$	$10120 \pm 40$
3634 <sup>b</sup>	0	$0^+$	$7983 \pm 3^d$	$10300 \pm 20$
$3915 \pm 2$	2	$2^+$	$8046 \pm 7$	$10400 \pm 10$
$4458 \pm 3$	1	$1^-$	$8140 \pm 10$	$10610 \pm 20$
$5105 \pm 2$	3	$3^-$	$8233 \pm 9$	
$5258 \pm 6$	2	$2^+$	$8294 \pm 5^d$	
$5340 \pm 4$	0	$0^+$	$8430 \pm 12$	
$5382 \pm 4$			$8521 \pm 3^d$	
$5530 \pm 4$			$8660 \pm 6$	
$6197 \pm 3$	1	$1^-$	$9030 \pm 15^e$	
$6356 \pm 7$	1, 2	$(1^-, 2^+)^c$	$9362 \pm 5^d$	
$6399 \pm 3$	3	$3^-$	$9420 \pm 20$	
$6885 \pm 9$			$9480 \pm 30$	
$7123 \pm 7$	4	$4^+$	$9671 \pm 8$	

<sup>a</sup> (1981CO13):  $E_t = 15$  MeV; DWBA analysis. See also Table 18.6 in (1978AJ03).

<sup>b</sup> Nominal energy.

<sup>c</sup> See, however, Table 18.18.

<sup>d</sup> Comparisons of  $E_x$  shown here with those displayed in Table 18.3 for  $^{18}\text{O}^*(3.92, 5.10, 6.40, 7.77)$  suggest that the uncertainty shown may be low:  $\pm 6$  keV was arbitrarily used in calculating the best value for  $E_x$  for this state in Table 18.3 of (1987AJ02).

<sup>e</sup> This is the “average” of several unresolved levels. (1985FO11) states that the main components are at 8.96 and 9.03 MeV. [Comment: It is not clear whether these states are actually resolved (1987AJ02).]

13.  $^{15}\text{N}(\alpha, \text{p})^{18}\text{O}$   $Q_{\text{m}} = -3.980$

Several states in  $^{18}\text{O}$  at  $E_{\text{x}} = 10\text{--}25$  MeV were observed in  $^{15}\text{N}(\alpha, \text{p})$  experiments reported in (1987MIZY, 1988BRZY, 1989BR1J).

14.  $^{15}\text{N}(^{13}\text{C}, ^{10}\text{B})^{18}\text{O}$   $Q_{\text{m}} = -8.042$

See (1983AJ01).

15.  $^{16}\text{O}(\text{t}, \text{p})^{18}\text{O}$   $Q_{\text{m}} = 3.706$

Proton groups corresponding to states of  $^{18}\text{O}$  are displayed in Table 18.15 here (1981CO13). See (1976LA13) for a general discussion of the properties of the states of  $^{18}\text{O}$ . Lifetime measurements are reported in Table 18.4 of (1978AJ03). See also reaction 19 and (1982AN12, 1985AN17, 1985BA1A).

16.  $^{16}\text{O}(\alpha, 2\text{p})^{18}\text{O}$   $Q_{\text{m}} = -16.108$

At  $E_{\alpha} = 65$  MeV, the angular distribution to  $^{18}\text{O}^*(3.55) [J^{\pi} = 4^+]$  has been studied.  $^{18}\text{O}^*(8.04, 9.15, 10.3)$  are also populated: see (1983AJ01).

17. (a)  $^{16}\text{O}(^{10}\text{B}, ^8\text{B})^{18}\text{O}$   $Q_{\text{m}} = -14.825$

(b)  $^{16}\text{O}(^{13}\text{C}, ^{11}\text{C})^{18}\text{O}$   $Q_{\text{m}} = -11.480$

At  $E(^{10}\text{B}) = 100$  MeV,  $^{18}\text{O}^*(3.55)$  [first  $(d_{5/2})_{4^+}^2$  state] is preferentially populated.  $^{18}\text{O}^*(1.98, 5.26, 7.12, 8.0, 8.3, 9.1)$  are also observed. The angular distribution to  $^{18}\text{O}^*(3.55)$  has been measured at  $E(^{13}\text{C}) = 105$  MeV. See (1983AJ01, 1983OS07).

18. (a)  $^{17}\text{O}(\text{n}, \gamma)^{18}\text{O}$   $Q_{\text{m}} = 8.044$

(b)  $^{17}\text{O}(\text{n}, \text{n}')^{17}\text{O}$   $E_{\text{b}} = 8.044$

(c)  $^{17}\text{O}(\text{n}, \alpha)^{14}\text{C}$   $Q_{\text{m}} = 1.817$

For reaction (a) see (1983AJ01). [The work reported there has not been published.] The scattering amplitude (bound)  $a = 5.62 \pm 0.45$  fm,  $\sigma_{\text{free}} = 3.55 \pm 0.25$  b. The thermal cross section for reaction (c) is  $235 \pm 10$  mb. See (1983AJ01) for references. See also (1988MCZT).

In more recent work, the cross section for  $^{17}\text{O}(n, \alpha)$  has been measured from  $E_n = 25 \times 10^{-3}$  eV to 1 MeV (1991KO31). An evaluation of the cross sections from  $E_n = 10^{-5}$  eV to 20 MeV has been carried out by (1991HI15). Results are given in tabular and graphical form. See also (1991KO1P).

19.  $^{17}\text{O}(d, p)^{18}\text{O}$

$$Q_m = 5.820$$

Table 18.16: States of  $^{18}\text{O}$  from  $^{17}\text{O}(d, p)$  <sup>a</sup>

$E_x$ (MeV $\pm$ keV) <sup>b</sup>	$l_n$ <sup>b</sup>	$J^\pi$ <sup>b</sup>	$S$ <sup>b</sup>
0	2	$0^+$	1.22
$1.982 \pm 10$	$0 + 2$	$2^+$	$0.21 + 0.83$
$3.552 \pm 10$	2	$4^+$	1.57
3.63	2	$0^+$	0.28
3.92	$0 + 2$	$2^+$	$0.35 + 0.66$
4.46	1	$1^-$	0.03
5.10	3	$3^-$	0.03
$5.255 \pm 10$	0	$2^+$	0.35
5.34	2	$0^+$	0.16
$5.375 \pm 10$	0	$3^+$	1.01
6.20	1	$1^-$	0.03
6.35	1	$(2^-)$	0.03
$7.110 \pm 15$	2	$4^+$	
$7.855 \pm 20$			
$7.962 \pm 20$			
9.0 <sup>c</sup>			

<sup>a</sup> See references in Tables 18.7 of (1972AJ02, 1978AJ03).

<sup>b</sup>  $E_x$  values without uncertainties are nominal.  $J$  are consistent with  $l_n$  and are used to calculate  $S$ .

<sup>c</sup> (1985FO11). See text.

Table 18.17: Some states in  $^{18}\text{O}$  from  $^{17}\text{O}(\alpha, ^3\text{He})$  <sup>a</sup>

$E_x$ (MeV) <sup>b</sup>	$J^\pi$ <sup>b</sup>	$\sigma_{\text{int}}$ (mb) <sup>c</sup>
0.0	$0^+$	0.22
1.98	$2^+$	0.64
3.55	$4^+$	1.59
5.38	$3^+$	0.12
7.12	$4^+$	0.09
7.86	$5^-$	0.14
8.12	$5^-$	0.06
8.82	$(1^+)$	0.04
11.06 <sup>a</sup>	$(6^-)$ <sup>a</sup>	0.18
13.85	$(6^-)$ <sup>d</sup>	0.02
14.17	$(6^-)$ <sup>d</sup>	0.01

<sup>a</sup> (1992YA08);  $E_\alpha = 65$  MeV.

<sup>b</sup>  $E_x$  and  $J^\pi$  values from Table (18.9).

<sup>c</sup> Integrated cross section. See Tables III and IV in (1992YA08) for spectroscopic factors.

<sup>d</sup> (1990SEZZ).

Observed proton groups are displayed in Table 18.16. A strong asymmetric peak is observed at  $E_d = 12$  MeV corresponding to  $E_x = 9.0$  MeV. On the basis of this work and the measurement of the cross section at a peak at about the same energy observed in the  $^{16}\text{O}(t, p)$  reaction, (1985FO11) assign  $J^\pi = 4^+$  and a  $(1d_{5/2})(1d_{3/2})$  configuration to  $^{18}\text{O}^*(9.0)$ . Proton- $\gamma$  coincidence measurements are shown in Table 18.10.

$$20. \ ^{17}\text{O}(\alpha, ^3\text{He})^{18}\text{O} \quad Q_m = -12.533$$

Differential cross sections were measured at  $E_\alpha = 65$  MeV (1992YA08) for  $^{18}\text{O}$  states up to  $E_x = 15$  MeV. DWBA analysis led to proposed spin parity and isospin assignments, and spectroscopic factors. See Table 18.17.

$$21. \ ^{17}\text{O}(^{12}\text{C}, ^{11}\text{C})^{18}\text{O} \quad Q_m = -10.677$$

Angular distributions involving  $^{18}\text{O}^*(0, 1.98, 3.55)$  have been studied at  $E(^{12}\text{C}) = 115$  MeV: see (1983AJ01).

Table 18.18: Branching in  $^{18}\text{N}(\beta^-)^{18}\text{O}$  <sup>a</sup>

Decay to $^{18}\text{O}^*$ (keV)	Decay mode	$J^\pi$	Branch <sup>b</sup> (%)	$\log ft$
$1982.05 \pm 0.09$ <sup>c</sup>	$\gamma$	$2^+$	$3.4 \pm 1.3$	$6.79 \pm 0.17$
$3554.13 \pm 0.80$	$\gamma$	$4^+$	$< 0.5$	$> 7.3$
$3633.70 \pm 0.11$	$\gamma$	$0^+$	$< 0.3$	$> 7.5$
$3920.42 \pm 0.14$	$\gamma$	$2^+$	$< 0.4$	$> 7.4$
$4455.52 \pm 0.10$	$\gamma$	$1^-$	$47.2 \pm 0.9$	$5.167 \pm 0.013$
$5097.60 \pm 0.60$	$\gamma$	$3^-$	$< 0.4$	$> 7.1$
$5530.17 \pm 0.32$	$\gamma$	$2^-$	$2.7 \pm 0.3$	$6.16 \pm 0.05$
$6198.22 \pm 0.40$	$\gamma$	$1^-$	$1.2 \pm 0.2$	$6.34 \pm 0.08$
$6349.76 \pm 1.0$	$\gamma$	$(2^-)$	$1.9 \pm 0.2$	$6.10 \pm 0.05$
$6880.45 \pm 0.27$	$\gamma$	$0^-$ <sup>d</sup>	$12.8 \pm 0.7$	$5.13 \pm 0.03$
7620	$\alpha$	$1^-$	$6.8 \pm 0.5$	$5.17 \pm 0.04$
$7771.07 \pm 0.50$	$\gamma$	$2^-$ <sup>d</sup>	$4.3 \pm 0.4$	$5.32 \pm 0.05$
8040	$\alpha$	$1^-$	$1.8 \pm 0.2$	$5.61 \pm 0.05$
9000 <sup>e</sup>	$\alpha$	$(1^-)$	$\geq 3.6 \pm 0.2$	$\leq 5.0$
$(9090 \pm 30)$	n	$(0-2)^-$	$0.16 \pm 0.03$	$6.27 \pm 0.09$
$9270 \pm 20$	n	$(0-2)^-$	$0.39 \pm 0.09$	$5.80 \pm 0.11$
$9470 \pm 20$	n	$(0-2)^-$	$0.47 \pm 0.09$	$5.64 \pm 0.09$
$9690 \pm 20$	n	$(0-2)^-$	$0.14 \pm 0.03$	$6.06 \pm 0.10$
$9910 \pm 20$	n	$(0-2)^-$	$0.17 \pm 0.03$	$5.87 \pm 0.08$
$10240 \pm 30$	n	$(0-2)^-$	$0.16 \pm 0.03$	$5.73 \pm 0.09$
$10650 \pm 30$	n	$(0-2)^-$	$0.43 \pm 0.09$	$5.07 \pm 0.10$
$10990 \pm 30$	n	$(0-2)^-$	$0.13 \pm 0.03$	$5.38 \pm 0.11$
$11490 \pm 30$	n	$(0-2)^-$	$0.19 \pm 0.04$	$4.85 \pm 0.10$

<sup>a</sup> Branchings to  $\gamma$ -decaying levels (1982OL01), branchings to  $\alpha$ -decaying levels (1989ZH04) and branchings to n-decaying levels (1994SC01).

<sup>b</sup>  $12.2 \pm 0.6\%$  of the  $\beta$ -decay branching ratio has been measured to feed  $\alpha$ -emitting states (1989ZH04).  $14.3 \pm 2.0\%$  has been measured to feed n-decaying states (1991RE02). The branching ratio of  $\gamma$ -decaying states (1982OL01) have been renormalized to take these values into account. See reaction 22 of  $^{18}\text{O}$ . Branchings in this table do not add up to 100% since n-decaying levels below 9.00 MeV were not measured by (1994SC01) and there is a missing 12.1% branching to n-decaying levels not listed.

<sup>c</sup>  $E_\gamma = 1981.933 \pm 0.09$  keV is adopted by (1982OL01).

<sup>d</sup> See (1982OL01).

<sup>e</sup> Found as a broad bump at 3 MeV in  $\beta$ -delayed alpha spectrum. Could be several unresolved  $1^-$  states or a new broad  $1^-$  state in  $^{18}\text{O}$  (1989ZH04).

22.  $^{18}\text{N}(\beta^-)^{18}\text{O}$

$$Q_m = 13.899$$

The transitions observed in the  $\beta^-$  decay are displayed in Table 18.18.

The  $\gamma$ -decaying states were measured by (1982OL01) and estimated  $15 \pm 6\%$  branching to non- $\gamma$ -decaying states in  $^{18}\text{O}$  was assumed. At least  $12.2 \pm 0.6\%$  of the  $\beta$ -decay branching ratio has been measured to feed  $1^-$  alpha-particle emitting states (1989ZH04). See also the measurements of (1987GAZW, 1987ZHJV, 1988MI1G). A  $\beta$ -delayed neutron emission probability of  $14.3 \pm 2.0\%$  has been measured (1991RE02). The  $\beta^-$  branchings to  $\gamma$ -emitting states of (1982OL01) has been renormalized to take in account the  $26.5 \pm 2.1\%$  branches to particle emitting states. The  $\gamma$ -ray intensities of (1982OL01) also need to be renormalized by this factor, see Table 18.19. (1994SC01) has measured  $\beta$  decay branching ratios to 9 neutron emitting states in  $^{18}\text{O}$  listed in Table 18.18 for a total of  $2.2 \pm 0.4\%$ .

23. (a)  $^{18}\text{O}(\gamma, n)^{17}\text{O}$

$$Q_m = -8.044$$

(b)  $^{18}\text{O}(\gamma, 2n)^{16}\text{O}$

$$Q_m = -12.187$$

(c)  $^{18}\text{O}(\gamma, p)^{17}\text{N}$

$$Q_m = -15.942$$

(d)  $^{18}\text{O}(\gamma, t)^{15}\text{N}$

$$Q_m = -15.834$$

(e)  $^{18}\text{O}(\gamma, pn + np)^{14}\text{C}$

$$Q_m = -34.522$$

(f)  $^{18}\text{O}(\gamma, \alpha)^{14}\text{C}$

$$Q_m = -6.227$$

The cross sections for the  $(\gamma, p)$ ,  $(\gamma, n)$ ,  $(\gamma, 2n)$  and  $(\gamma, \text{tot})$  [tot = total absorption] have been measured with monoenergetic photons to 42 MeV: observed resonances are displayed in Table 18.20. All three of the partial cross sections have substantial strength in the giant resonance region; the  $(\gamma, 2n)$  cross section is a significant fraction of  $\sigma(\gamma, \text{tot})$  and is even larger than  $\sigma(\gamma, p)$ . Above the GDR the partial cross sections decrease. The integrated  $\sigma(\gamma, \text{tot})$  between 29 and 42 MeV is about one-third of the value integrated from threshold to 42 MeV. The relative strengths of partial cross sections leads to the  $T$  assignments shown in Table 18.20. The  $T_<$  and  $T_>$  components of the  $^{18}\text{O}$  photo absorption cross section are also derived (1979WO04).

In a related, but more recent, experiment the cross section for reaction (e) was measured (1991MC01) and it was determined that the cross section rises to a maximum of 1.2 mb at 27.5 MeV, approximately one-tenth of the total  $(\gamma, n)$  cross section there. The cross section integrated to 43 MeV is only 11.8 mb · MeV, and as a result the isospin assignments of (1979WO04) are unaffected by neglect of this channel. A recent extensive study of isospin effects in the photodisintegration of light nuclei (1993MC02) used a collection of data on  $(\gamma, p)$ ,  $(\gamma, n)$ ,  $(\gamma, 2n)$  and  $(\gamma, n_0)$  cross sections and separated the  $T_>$  and  $T_<$  isospin components of the GDR in several light nuclei including  $^{18}\text{O}$ . The relative strengths were extracted. See also the atlas of photoneutron cross sections with monoenergetic photons (1988DI02), and see (1988BE1T, 1989NO1C). Structures in the  $(\gamma, \alpha_0)$  cross section are reported at  $E_x = 18.2, 20.9, 22.1,$  and  $24.2$  MeV (1982BA03;  $E_{\text{brems.}}$ ). The decay of the GDR to  $^{14}\text{C}$ ,  $^{15}\text{N}$ ,  $^{16}\text{O}$ ,  $^{17}\text{N}$  and  $^{17}\text{O}$  states has been studied: see (1983AJ01). Less



Table 18.19:  $\gamma$ -ray intensities observed in  $^{18}\text{N}(\beta^-)^{18}\text{O}$  <sup>a</sup>

$E_\gamma$ (keV) <sup>b</sup>	$E_i$ (keV)	$E_f$ (keV)	$I_\gamma$ <sup>c</sup>
$535.24 \pm 0.05$	4456	3920	$2.85 \pm 0.14$
$821.71 \pm 0.09$	4456	3634	$60.6 \pm 1.8$
$1074.8 \pm 0.6$	5530	4456	$0.80 \pm 0.12$
$1177.3 \pm 0.9$	5098	3920	$0.42 \pm 0.13$
$1572.0 \pm 0.8$	3554	1982	$0.64 \pm 0.13$
$1609.6 \pm 0.9$	5530	3920	$0.85 \pm 0.34$
$1651.56 \pm 0.07$	3634	1982	$60.5 \pm 1.8$
$1893.9 \pm 0.9$	6350	4456	$0.37 \pm 0.06$
$1938.2 \pm 0.2$	3920	1982	$4.49 \pm 0.14$
$1981.93 \pm 0.09$	1982	0	$98.0 \pm 2.0$
$2424.8 \pm 0.3$	6880	4456	$17.53 \pm 0.70$
$2429.7 \pm 0.8$	6350	3920	$1.41 \pm 0.14$
$2473.0 \pm 0.3$	4456	1982	$20.4 \pm 1.0$
$2673.0 \pm 0.5$	7771	5098	$1.63 \pm 0.16$
$3114.5 \pm 0.6$	5098	1982	$0.92 \pm 0.14$
$3315.1 \pm 0.9$	7771	4456	$0.63 \pm 0.25$
$3547.7 \pm 0.4$	5530	1982	$2.01 \pm 0.14$
$3920.1 \pm 0.9$	3920	0	$0.65 \pm 0.07$
$4366.0 \pm 0.8$	6350	1982	$0.84 \pm 0.21$
$5788.5 \pm 0.7$	7771	1982	$3.58 \pm 0.32$
$6197.1 \pm 0.4$	6198	0	$1.40 \pm 0.14$

<sup>a</sup> (1982OL01).

<sup>b</sup>  $\gamma$ -ray energies have not been corrected for nuclear recoil.

<sup>c</sup>  $\gamma$ -ray intensities are normalized such that the flux into the ground state is 100. To obtain  $\gamma$ -ray intensities per 100 parent decays multiply by  $0.735 \pm 0.021$  (see reaction 22 under  $^{18}\text{O}$  for discussion of this normalization).

than 20% of the decay of states with  $14.5 < E_x < 20$  MeV goes via the  $n_0$  channel (1987JU07). See (1978AJ03, 1987AJ02) for the earlier work.

24.  $^{18}\text{O}(\gamma, \gamma)^{18}\text{O}$

For  $^{18}\text{O}^*(6.20)$   $\Gamma_{\gamma_0} = 0.18 \pm 0.03$  eV, assuming  $\Gamma_{\gamma_0}/\Gamma = 0.88$ ;  $E_x = 6202.7 \pm 0.8$  keV: see (1978AJ03).

25.  $^{18}\text{O}(e, e')^{18}\text{O}$

The  $^{18}\text{O}$  charge radius,  $\langle r^2 \rangle^{1/2} = 2.784 \pm 0.020$  fm, based on studies of the elastic charge form factors for  $E_e = 70$  to 370 MeV, the resulting determinations of the difference in the  $^{18}\text{O}$  and  $^{16}\text{O}$  radii, and the rms radius of  $^{16}\text{O}$ : see (1983AJ01).

Inelastic scattering has been reported to many states of  $^{18}\text{O}$ : see (1983AJ01, 1987AJ02) and Table 18.21 here which also includes the recent work reported in (1995SE02). See also the comment (1987MI25) and reply (1987MA40) on the work reported in (1986MA48). Recent measurements are reported for  $4^-$  and  $6^-$  states at  $E_e = 140$ –275 MeV (1990SEZZ), and for  $1^-$ ,  $3^-$ ,  $5^-$  states (1991MA14). Form factor measurements for the  $2^+$  level at  $E_x = 8.21$  MeV and the  $(2^+)$  level at  $E_x = 9.3$  MeV at momentum transfer  $0.9 < q < 2.1$  fm $^{-1}$  (1990MA06) and for the  $1^-$ ,  $3^-$  and  $5^-$  levels at  $0.6 < q < 2.7$  fm $^{-1}$  (1991MA14) are reported.

Several theoretical studies of inelastic electron scattering to states of  $^{18}\text{O}$  have been carried out. A microscopic calculation for scattering to  $2^+$  states is reported in (1988HAZZ) and to  $0^+$  and  $2^+$  states in (1988KU17). See also the calculations of transition charge densities described in (1988GU03, 1988GU12, 1992GU11) and see (1987GUID, 1988GU1B, 1989AJ1A).

26. (a)  $^{18}\text{O}(\pi^\pm, \pi^\pm)^{18}\text{O}$

(b)  $^{18}\text{O}(\pi^\pm, \pi^\pm p)^{17}\text{N}$   $Q_m = -15.942$

(c)  $^{18}\text{O}(\pi^-, \pi^- n)^{17}\text{O}$   $Q_m = -8.044$

Angular distributions for the scattering to  $^{18}\text{O}^*(0, 1.98, 5.10)$  have been reported at  $E_{\pi^\pm} = 29.2$  to 230 MeV [see (1983AJ01)] and at 50 MeV (1984TA1A;  $^{18}\text{O}^*(0, 1.98)$ ) at 140, 180, and 220 MeV (1984SE1A;  $^{18}\text{O}^*(1.98)$ ), at 164 MeV (1987CH14;  $^{18}\text{O}^*(0, 1.98, 4.46, 5.10)$ ) and (1988SE04;  $^{18}\text{O}^*(1.98, 3.92, 5.26$  MeV)). See also (1989GR1M, 1990WI1K). Measurements and analysis work reported in (1983AJ01) determine  $\langle r_n^2 \rangle^{1/2} = 2.81 \pm 0.03$  fm,  $\langle r_n^2 \rangle^{1/2} - \langle r_p^2 \rangle^{1/2} = 0.03 \pm 0.03$  fm. For a discussion of proton matter distribution in  $^{18}\text{O}$  see (1985BA27). Total reaction cross sections at  $E_\pi = 50$  MeV

Table 18.20: Resonances in  $^{18}\text{O} + \gamma$

$E_x$ (MeV) <sup>a</sup>				$\sigma$ (mb)	$\Gamma$ (MeV)
( $\gamma$ , tot)	( $\gamma$ , n)	( $\gamma$ , 2n)	( $\gamma$ , p)		
9.1	9.1			1.1 <sup>b</sup>	0.6
10.3	10.3			5.3 <sup>b</sup>	0.9
11.4	11.4			9.0 <sup>b</sup>	0.7
13.1	13.1	13.2		8.6 <sup>b</sup>	0.7
13.8	13.8	13.9		6.9 <sup>b</sup>	0.6
14.7	14.7	14.8		13.1 <sup>b</sup>	0.8
15.8	15.7	15.8		10.9 <sup>b</sup>	0.7
17.3 <sup>c</sup>	17.1		17.5	10.1 <sup>b</sup> , 1.2 <sup>e</sup>	0.6
19.4 <sup>c</sup>		(19.1)	19.4	10.0 <sup>b</sup> , 1.8 <sup>e</sup>	0.9
21.1 <sup>d</sup>		21.1	21.0	9.7 <sup>b</sup> , 1.2 <sup>e</sup>	
22.6	(22.6)	22.7	22.7		
23.7 <sup>d</sup>	23.7	23.5	23.7	17.7 <sup>b</sup> , 6.1 <sup>e</sup>	1.6
27 <sup>c</sup>	27		27 – 28		
30 <sup>f</sup>	30				
36 <sup>f</sup>					

<sup>a</sup> (1979WO04). See also (1987JU07, 1993MC02) and Table 18.9 in (1983AJ01).

<sup>b</sup>  $\sigma(\gamma, n) + 2\sigma(\gamma, 2n)$ .

<sup>c</sup>  $T = 2$ : see (1979WO04).

<sup>d</sup>  $T = 1$ : see (1979WO04).

<sup>e</sup>  $\sigma(\gamma, p)$ .

<sup>f</sup> Weak and broad resonances: may indicate the presence of particle-hole states at these high energies.

Table 18.21: Some states of  $^{18}\text{O}$  from  $^{18}\text{O}(e, e')$  <sup>a</sup>

$E_x$ (MeV)	$\Gamma$ (keV)	$J^\pi; T$	Mult.	Transition probability (in $e^2 \cdot \text{fm}^{2\lambda}$ )
1.98 <sup>b</sup>		$2^+; 1$	C2	$44.8 \pm 1.3$
3.55 <sup>b</sup>		$4^+; 1$	C4	$(9.04 \pm 0.90) \times 10^2$
3.92 <sup>b</sup>		$2^+; 1$	C2	$22.2 \pm 1.0$
4.46 <sup>c</sup>		$1^-$		
5.10 <sup>c</sup>		$3^-$	C3	$1301 \pm 39$
5.26 <sup>b</sup>		$2^+; 1$	C2	$28.3 \pm 1.5$
$5.53 \pm 0.01$ <sup>e</sup>	$< 50$	$2^-; 1$		
6.20 <sup>c</sup>		$1^-$		
$6.35 \pm 0.01$ <sup>e</sup>	$< 50$	$(2^-); 1$		
6.40 <sup>c</sup>		$3^-$	C3	$40 \pm 9$
7.12 <sup>b</sup>		$4^+; 1$	C4	$(1.31 \pm 0.06) \times 10^4$
7.62 <sup>c</sup>		$1^-$		
$7.77 \pm 0.01$ <sup>e</sup>	$< 50$	$2^-; 1$		
7.86 <sup>c</sup>		$5^-$	C5	$(3.54 \pm 0.64) \times 10^4$
8.04 <sup>c</sup>		$1^-$		
8.13 <sup>c</sup>		$5^-$	C5	$(1.88 \pm 0.35) \times 10^4$
8.21 <sup>d</sup>		$2^+; (1)$	C2	$7.3 \pm 4.2$
8.29 <sup>c</sup>		$3^-$	C3	$\leq 19$
$8.41 \pm 0.01$ <sup>e</sup>	$< 50$	$(2^-); 1$		
$8.52 \pm 0.01$ <sup>e</sup>	$< 50$	$(4^-); 1$		
$8.82 \pm 0.01$ <sup>e</sup>	$70 \pm 12$	$(1^+); 1$		
$8.96 \pm 0.01$ <sup>e</sup>	$43 \pm 3$	$(4^+); 1$		
$9.36 \pm 0.01$ <sup>d, e</sup>	$\leq 20$	$(2^+); 1$		
$9.71 \pm 0.01$ <sup>e</sup>	$< 50$	$(5^-); 1$		
$10.31 \pm 0.02$ <sup>e</sup>	$< 50$	$(4^+); 1$		
$10.43 \pm 0.04$ <sup>e</sup>	$< 50$	$(2^-); 1$		
$10.67 \pm 0.02$ <sup>e</sup>	$< 50$	$(2^-); 1$		
$10.99 \pm 0.02$ <sup>e</sup>	$< 50$	$(2^-); 1$		
$11.52 \pm 0.05$ <sup>e</sup>	$< 50$	$(2^-); 1$		
$11.67 \pm 0.02$ <sup>e</sup>	$112 \pm 7$	$(3^-); 1$		

Table 18.21: Some states of  $^{18}\text{O}$  from  $^{18}\text{O}(e, e')$  <sup>a</sup> (continued)

$E_x$ (MeV $\pm$ keV)	$\Gamma$ (keV)	$J^\pi; T$	Mult.	Transition probability (in $e^2 \cdot \text{fm}^{2\lambda}$ )
$11.90 \pm 0.03$ <sup>e</sup>	$< 50$	$(2^-); 1$		
$12.09 \pm 0.02$ <sup>e</sup>	$< 50$	$(1^-, 2^+); 1$		
$12.41 \pm 0.02$ <sup>e</sup>	$143 \pm 24$	$(3^-); 1$		
$12.52 \pm 0.02$ <sup>e</sup>	$< 50$			
$12.66 \pm 0.02$ <sup>e</sup>	$< 50$	$(2^-); 1$		
$12.99 \pm 0.02$ <sup>e</sup>	$68 \pm 18$	$(4^-); 1$		
$13.40 \pm 0.02$ <sup>e</sup>	$108 \pm 26$	$(2^-); 1$		
$13.85 \pm 0.13$ <sup>e</sup>	$\approx 200$	$(6^-); 1$		
$14.17 \pm 0.04$ <sup>e</sup>	$140 \pm 50$	$(6^-); 1$		
$14.45 \pm 0.05$ <sup>e</sup>	$\approx 1070$			
$15.23 \pm 0.04$ <sup>e</sup>	$\approx 300$			
$15.95 \pm 0.03$ <sup>e</sup>	$< 50$			
$16.210 \pm 0.01$ <sup>f, g</sup>		$1^{(-)}$		
$16.315 \pm 0.01$ <sup>f, g</sup>		$(3, 2)^-$		
$16.399 \pm 0.005$ <sup>f, h</sup>	$< 20$	$2^-; 2^i$	M2	$(64 \pm 8) \times 10^{-2}$
$16.40 \pm 0.02$ <sup>e</sup>	$< 50$	$(2^-); 2$		
$16.88 \pm 0.03$ <sup>e</sup>	$< 50$	$(4^-, 2^-); 1$		
$16.948 \pm 0.01$ <sup>f, g</sup>		$(3, 2)^-$		
$17.025 \pm 0.01$ <sup>e, f, g, h</sup>	$20 \pm 6$	$(3^-); 2$		
$17.398 \pm 0.01$ <sup>f, g</sup>		$(2, 1, 3)^-$		
$17.450 \pm 0.01$ <sup>f, g</sup>		$(2, 1, 3)^-$		
$17.46 \pm 0.03$ <sup>e</sup>	$\approx 600$	$(4^-); 1$		
$17.5$ <sup>f</sup>	$\approx 150$			
$17.502 \pm 0.01$ <sup>f, g</sup>		$(1, 2, 3)^-$		
$17.635 \pm 0.01$ <sup>f, g</sup>				
$18.049 \pm 0.01$ <sup>f, g</sup>		<sup>d</sup>		
$18.2$ <sup>f</sup>	$\approx 150$			
$18.45 \pm 0.02$ <sup>e</sup>	$75 \pm 27$	$(3^-); 1$		
$18.5$ <sup>f</sup>	$\approx 4300$			
$18.68 \pm 0.02$ <sup>e, h</sup>	$< 50$	$(4^-); 2$		$63 \pm 8$ <sup>h</sup>

Table 18.21: Some states of  $^{18}\text{O}$  from  $^{18}\text{O}(e, e')$  <sup>a</sup> (continued)

$E_x$ (MeV $\pm$ keV)	$\Gamma$ (keV)	$J^\pi; T$	Mult.	Transition probability (in $e^2 \cdot \text{fm}^{2\lambda}$ )	
18.871 $\pm$ 0.005 <sup>f</sup>		1 <sup>+</sup> ; 2	M1	$(3.1 \pm 0.4) \times 10^{-2}$	
18.927 <sup>f, g</sup>		1 (2 <sup>+</sup> )			
19.027 $\pm$ 0.01 <sup>f, g</sup>		(1, 3) <sup>-</sup>			
19.150 $\pm$ 0.01 <sup>f, g</sup>		1 <sup>-</sup> (2 <sup>+</sup> , 3 <sup>-</sup> )			
19.22 $\pm$ 0.02 <sup>e</sup>	< 50	(3 <sup>-</sup> ; 2)			
19.7 <sup>f</sup>	$\approx$ 200				
20.2 <sup>f</sup>	$\approx$ 180				
20.36 $\pm$ 0.02 <sup>e, h</sup>	< 20	(4 <sup>-</sup> ); 2	M4		66 $\pm$ 6
20.86 $\pm$ 0.02 <sup>e</sup>	97 $\pm$ 41				
21.0 <sup>f</sup>	$\approx$ 150				
21.42 $\pm$ 0.02 <sup>e, h</sup>	49 $\pm$ 37	(4 <sup>-</sup> ; 2)		400 $\pm$ 32	
22.40 $\pm$ 0.02 <sup>e, f, h</sup>	91 $\pm$ 8 <sup>e</sup>	4 <sup>-</sup> ; 2 <sup>e</sup>	M4		
23.10 $\pm$ 0.02 <sup>e</sup>	49 $\pm$ 24				
23.8 <sup>f</sup>	$\approx$ 1300				

<sup>a</sup> Additional states have been excited: see reaction 28 in (1983AJ01). For ground state see reaction 25 here.

<sup>b</sup> (1982NO04).

<sup>c</sup> (1991MA14).

<sup>d</sup> (1990MA06).

<sup>e</sup> (1995SE02).

<sup>f</sup> (1983BE36).

<sup>g</sup> Weakly excited.

<sup>h</sup> (1986MA48).

<sup>i</sup> See Fig. 5 for missing  $T = 2$  strength.

have been determined by (1987ME12). At  $E = 165$  MeV, the cross section for reaction (c) is larger for  $^{18}\text{O}$  than for  $^{16}\text{O}$  while reaction (b) has a lower cross section (1982PI06). For the ( $\pi^+$ , 2p), ( $\pi^+$ , pn) and ( $\pi^-$ , pn) reactions at  $E_\pi = 165$  MeV see (1984AL20, 1986AL22).

Results of Glauber model calculations of pion scattering from  $^{18}\text{O}$  at energies above the  $\Delta_{33}$  resonance are presented in (1991OS01). A microscopic study of inelastic scattering to the 2<sup>+</sup> states in  $^{18}\text{O}$  is reported in (1988HAZZ). See also the review of pion-nucleus physics in (1991MO13).

## 27. $^{18}\text{O}(n, n')^{18}\text{O}$

Angular distributions have been measured for  $E_n = 2.9$  to 24 MeV [see (1972AJ02, 1983AJ01)] and at  $E_n = 5.0$  to 7.5 MeV (1986KO10;  $n_0, n_1$ ).

## 28. $^{18}\text{O}(p, p')^{18}\text{O}$

Angular distributions have been measured for  $E_p = 0.84$  to 135 MeV [see (1978AJ03, 1983AJ01)], at  $E_p = 135$  MeV (1986KE05;  $p_1$ ) and at  $E_p = 800$  MeV (1982GL08;  $p$  to  $^{18}\text{O}^*(0, 1.98, 7.12)$ .) At  $E_p = 24.5$  MeV (1974ES02) have studied the angular distributions of the proton groups to  $^{18}\text{O}^*(1.98, 3.55, 3.63, 3.92, 4.46, 5.10, 5.26, 5.53, 7.12)$ : a modified DWBA analysis leads to  $J^\pi = 2^+, 4^+, 0^+, 2^+, 1^-, 3^-, 2^+, 2^-$  and  $4^+$  for these states. A coupled-channels calculation suggests  $\beta_2 = 0.37 \pm 0.03, 0.56 \pm 0.06$  and  $0.18 \pm 0.04$  for  $^{18}\text{O}^*(1.98, 5.10, 7.12)$ . Such calculations also support evidence for a rotational band involving  $^{18}\text{O}^*(0, 1.98, 7.12)$ . The  $3^-$  state at 5.10 MeV is strongly excited and collective in nature:  $B(E3) = 1120 e^2 \cdot \text{fm}^6$ . For  $^{18}\text{O}^*(1.98, 3.92, 5.26)$ ,  $B(E2) = 45, 8.3$  and  $24 e^2 \cdot \text{fm}^4$  (1974ES02). The 800 MeV data indicates that  $^{18}\text{O}^*(7.12)$  can be described only if a large hexadecapole deformation is assumed (1982GL08). At  $E_p = 201$  MeV,  $\sigma(\theta)$  at forward angles has been measured to  $^{18}\text{O}^*(8.21, 8.82, 16.40)$ : it is proposed that  $^{18}\text{O}^*(8.82)$  has  $J^\pi = 1^+$  and that additional  $1^+$  strength is located in a group centered at  $E_x \approx 10.1$  MeV as well as in the region  $E_x = 12.4$  to 15 MeV. The  $1^+; T = 2$  state  $^{18}\text{O}^*(18.87)$ , reported in (e, e'), is not observed (1987DJ01). See also (1988CR1B).

$^{18}\text{O}^*(1.98)$  has  $|g| = 0.287 \pm 0.015$  [ $\tau_m = 2.99 \pm 0.12$  ps].  $^{18}\text{O}^*(3.55)$  has  $|g| = 0.62 \pm 0.10$  suggesting a mainly  $(d_{5/2})^2$  configuration for this state: see (1983AJ01). See also  $^{19}\text{F}$  and (1987AJ02).

A Dirac optical model analysis of  $^{18}\text{O}(p, p)$  cross section and analyzing power at 800 MeV is described in (1990PH02). A coupled-channels analysis was presented in (1988DE31). The intrinsic radial sensitivity of nucleon inelastic scattering was studied by (1988KE01) and a comparison of electromagnetic and hadronic probes of nuclear structures is described in (1986KE1C).

## 29. $^{18}\text{O}(\bar{p}, \bar{p}')^{18}\text{O}$

Angular distributions are reported with 178.4 MeV antiprotons to  $^{18}\text{O}^*(0, 1.98)$  (1986BR04, 1986LE13). For atomic effects see (1986KO22). See also (1987AJ02).

Differential cross sections for elastic and inelastic scattering of 180 MeV antiprotons by  $^{18}\text{O}$  were calculated in the eikonal and Glauber approaches by (1992TA08).

## 30. $^{18}\text{O}(d, d)^{18}\text{O}$

Angular distributions have been reported at  $E_d = 7.0$  to 15.0 MeV: see (1972AJ02, 1983AJ01). See also  $^{20}\text{F}$ .

31.  $^{18}\text{O}(t, t')^{18}\text{O}$

See (1972AJ02).

32.  $^{18}\text{O}(^3\text{He}, ^3\text{He}')^{18}\text{O}$

The elastic scattering has been studied at  $E(^3\text{He}) = 11.0$  to  $41$  MeV [see (1972AJ02, 1983AJ01)] and at  $14$  MeV (1982AB04), at  $25$  MeV (1982VE13) [the matter radius,  $\langle r^2 \rangle_m^{1/2} = 2.59 \pm 0.12$  fm] and at  $33$  MeV (1983LE03; also  $A_\gamma$ ; and also to  $^{18}\text{O}^*(1.98)$ ). A strong-absorption model analysis of angular distributions at  $2.5$  and  $41$  MeV is described in (1987RA36). See also (1985HA11, 1987CO07).

33.  $^{18}\text{O}(\alpha, \alpha')^{18}\text{O}$

Recent elastic scattering cross sections at  $E_\alpha = 44.8$  MeV were reported by (1992AR18). Angular distributions of many  $\alpha$ -groups have been measured in the range  $E_\alpha = 21$  to  $40.5$  MeV [see (1978AJ03)], at  $23.5$  MeV (1984SA28; to  $^{18}\text{O}^*(1.98, 3.56 + 3.63, 3.92, 4.45, 5.1-5.53)$ ) and at  $54.1$  MeV (1987AB03; g.s.). The transitions to  $^{18}\text{O}^*(4.46, 5.10)$  are  $L = 1$  and  $3$ , respectively, fixing  $J^\pi = 1^-$  and  $3^-$  for these states. Measurements of  $\alpha$ -groups near  $180^\circ$  for  $E_\alpha = 20.0$  to  $23.4$  MeV confirm assignments of natural parity for  $^{18}\text{O}^*(1.98, 3.55, 3.63, 3.92, 4.46, 5.10, 5.26, 5.34, 6.20, 6.40, 7.12, 7.62, 7.86, 8.22, 8.29, 8.82, 8.96, 9.03, 9.10, 9.36, 9.41, 9.67, 9.72 \pm 0.03, 9.88, 10.12, 10.30, 10.40, 11.62, 11.69)$ . [See, however, Table 18.9.] Levels at  $E_x = 5.38, 8.48$  and  $8.64$  MeV were not observed, and those at  $5.53, 6.35$  and  $6.88$  MeV were populated weakly indicating unnatural parity;  $J^\pi = 3^+$  and  $2^-$  respectively for  $^{18}\text{O}^*(5.38, 5.53)$ .

Alpha-gamma correlation measurements involving  $^{18}\text{O}$  states below  $E_x = 6.4$  MeV [see Table 18.10] lead to  $J^\pi = 1^-$  and  $3^-$  for  $^{18}\text{O}^*(6.20, 6.40)$ . Other  $J^\pi$  values agree with previous assignments. The transitions  $3.92 \rightarrow 1.98$  and  $5.26 \rightarrow 1.98$  are almost pure M1. For  $\tau_m$  measurements, see Table 18.4 in (1978AJ03). For references see (1983AJ01, 1987AJ02). A microscopic investigation of the  $\alpha + ^{18}\text{O}$  system in a three-cluster model is discussed in (1988DE37).

34. (a)  $^{18}\text{O}(^6\text{Li}, ^6\text{Li}')^{18}\text{O}$

(b)  $^{18}\text{O}(^7\text{Li}, ^7\text{Li}')^{18}\text{O}$

See (1972AJ02, 1983AJ01).

35. (a)  $^{18}\text{O}(^9\text{Be}, ^9\text{Be}')^{18}\text{O}$

(b)  $^{18}\text{O}(^9\text{Be}, \pi^- n)\text{X}$  (not observed)



A recent search for a bound system of  $\pi^-$  and neutrons in the fragmentation region of  $^{18}\text{O} + ^9\text{Be}$  collisions at  $100 A \cdot \text{MeV}$  is reported in (1993SU08). Upper limits were obtained.

See also (1972AJ02, 1987AJ02).

36. (a)  $^{18}\text{O}(^{10}\text{B}, ^{10}\text{B}')^{18}\text{O}$   
 (b)  $^{18}\text{O}(^{11}\text{B}, ^{11}\text{B}')^{18}\text{O}$

An elastic angular distribution has been reported at  $E(^{11}\text{B}) = 115 \text{ MeV}$ : see (1983AJ01). For reaction (a) see (1974AJ01).

A recent measurement of  $^{18}\text{O}$  on  $^{10,11}\text{B}$  targets at  $E_{\text{lab}} \approx 55 \text{ MeV}$  is described in (1993AN08) and evidence for fusion-fission rather than orbiting is reported. See also (1990SZ1C).

37. (a)  $^{18}\text{O}(^{12}\text{C}, ^{12}\text{C}')^{18}\text{O}$   
 (b)  $^{18}\text{O}(^{13}\text{C}, ^{13}\text{C}')^{18}\text{O}$   
 (c)  $^{18}\text{O}(^{14}\text{C}, ^{14}\text{C}')^{18}\text{O}$   
 (d)  $^{18}\text{O}(^{12}\text{C}, \alpha^{12}\text{C}')^{14}\text{C}$   $Q_m = -6.227$

Elastic angular distributions have been studied at  $E(^{18}\text{O}) = 32.3$  to  $57.5 \text{ MeV}$  for reaction (a) [as well as at  $E(^{18}\text{O}) = 70, 100, \text{ and } 140 \text{ MeV}$  (1982HE07)] and at  $E(^{18}\text{O}) = 31 \text{ MeV}$  for reaction (b). Yields and fusion cross sections are reported by (1982BA49, 1982HE07, 1985BE40, 1985CA01, 1986GA13). For reaction (c) see (1986STZY). See also (1983AJ01, 1987AJ02).

Angular correlations (reaction (d)) have been studied at  $E(^{18}\text{O}) = 82 \text{ MeV}$ .  $^{18}\text{O}^*(7.10, 7.62, 7.86, 8.04, 8.22, 10.30, 11.59, 12.55)$  are observed: the first seven of these have  $J^\pi = 4^+, 1^-, 5^-, 1^-, 2^+, 4^+, 5^-$  (1984BH01, 1984RA07). In addition  $^{18}\text{O}^*(9.33, 9.65)$  are also populated [ $\Gamma \approx 0.3 \text{ MeV}$ ]: a possible interpretation of the data is that these two are  $3^-$  states and that there is in addition a very wide ( $> 1 \text{ MeV}$ )  $2^+$  state at  $\approx 9.5 \text{ MeV}$  (1984RA17). See also (1987AJ02).

Giant dipole decays in nuclei excited by  $^{18}\text{O} + ^{12}\text{C}$  collisions were discussed in (1989BEZC, 1990SN1A). Competition between p2n, dn and t emissions in the  $^{12}\text{C} + ^{18}\text{O}$  reaction was studied in an experiment reported in (1990XE01).

Predictions of possible resonant behavior in medium-mass colliding systems are discussed in (1989CI1C). Molecular single particle effects for  $^{12}\text{C} + ^{18}\text{O}$  are explored in calculations described in (1987MO27).

38.  $^{18}\text{O}(^{15}\text{N}, ^{15}\text{N}')^{18}\text{O}$

See (1983DU13).

39.  $^{18}\text{O}(^{16}\text{O}, ^{16}\text{O}')^{18}\text{O}$

Angular distributions have been measured at many energies for  $E(^{16}\text{O}) = 24$  to  $54.5$  MeV and  $E(^{18}\text{O}) = 25$  to  $52$  MeV, involving besides  $^{18}\text{O}_{\text{g.s.}}$ ,  $^{18}\text{O}^*(1.98, 3.55 + 3.63, 3.92, 4.46, 5.10, 7.12)$ . At  $E(^{18}\text{O}) = 126$  MeV  $^{18}\text{O}^*(9.0)$  is relatively strongly populated. See (1983AJ01). For yields and fusion cross sections, including the effect of  $^{18}\text{O}^*(1.98)$ , see (1985TH03, 1985WU03, 1986GA13, 1986TH01). See also (1987AJ02). Competition between p2n, dn and t emissions in  $^{18}\text{O} + ^{16}\text{O}$  reactions was studied in an experiment reported in (1990XE01).

A unified description of sub-barrier interactions of oxygen isotopes is discussed in (1987PO11); see the coupled-channels calculations reported in (1992LI1K). See also the review of sub-barrier fusion in (1988BE1W). A semi-classical analysis of two particle transfer in  $^{16}\text{O} + ^{18}\text{O}$  reactions is discussed in (1987MA22).

40. (a)  $^{18}\text{O}(^{17}\text{O}, ^{17}\text{O}')^{18}\text{O}$

(b)  $^{18}\text{O}(^{18}\text{O}, ^{18}\text{O}')^{18}\text{O}$

Angular distributions involving  $^{18}\text{O}^*(0, 1.98)$  are reported at  $E(^{17}\text{O}) = 36$  MeV. Angular distributions [reaction (b)] have been studied at  $E(^{18}\text{O}) = 20$  to  $52$  MeV.  $^{18}\text{O}^*(3.55 + 3.63, 4.46, 5.10, 7.12)$  are also populated; see (1978AJ03, 1983AJ01). See also (1987AJ02) and see (1990XE01) reporting on p2n, dn and t emissions in  $^{18}\text{O} + ^{18}\text{O}$  reactions.

The effect of high spin states on fusion in  $^{18}\text{O} + ^{18}\text{O}$  systems has been studied in the framework of a statistical theory (1987RA28).

41.  $^{18}\text{O}(^{19}\text{F}, ^{19}\text{F}')^{18}\text{O}$

The elastic scattering has been studied at  $E(^{19}\text{F}) = 27, 30,$  and  $33$  MeV: see (1983AJ01). See also (1987AJ02). An experiment reported in (1990XE01) studied p2n, dn and t emission in  $^{18}\text{O} + ^{19}\text{F}$  reactions.

42. (a)  $^{18}\text{O}(^{24}\text{Mg}, ^{24}\text{Mg}')^{18}\text{O}$

(b)  $^{18}\text{O}(^{26}\text{Mg}, ^{26}\text{Mg}')^{18}\text{O}$

Angular distributions are reported for reaction (a) at  $E(^{18}\text{O}) = 29$  and  $35$  MeV to  $^{18}\text{O}^*(0, 1.98)$ . See (1987AJ02).

43.  $^{18}\text{O}(^{27}\text{Al}, ^{27}\text{Al}')^{18}\text{O}$

The elastic angular distribution has been studied at  $E(^{18}\text{O}) = 100$  MeV (1981ME13). See also (1983AJ01, 1987AJ02).

44.  $^{18}\text{O}(^{28}\text{Si}, ^{28}\text{Si}')^{18}\text{O}$

Elastic angular distributions are reported at  $E(^{18}\text{O}) = 36$  to  $56$  MeV [see (1983AJ01)] and at  $351.7$  MeV (1984BUZX, 1988BU15; also to  $^{18}\text{O}^*(1.98)$ ). See also (1987AJ02).

Ambiguities in optical-model potentials for describing  $^{18}\text{O} + ^{28}\text{Si}$  and other heavy-ion reactions are discussed in (1987HO18). See also (1989NA1M).

45. (a)  $^{18}\text{O}(^{40}\text{Ca}, ^{40}\text{Ca}')^{18}\text{O}$

(b)  $^{18}\text{O}(^{44}\text{Ca}, ^{44}\text{Ca}')^{18}\text{O}$

(c)  $^{18}\text{O}(^{48}\text{Ca}, ^{48}\text{Ca}')^{18}\text{O}$

Angular distributions have been measured at  $E(^{18}\text{O}) = 62.1$  MeV [reaction (a)] for the transitions to  $^{18}\text{O}^*(0, 1.98, 5.10)$  (1982RE14). For a fusion study [reaction (b)] see (1984DE38). See also (1987AJ02, 1987SC34).

46.  $^{18}\text{F}(\beta^+)^{18}\text{O}$   $Q_m = 1.655$

See  $^{18}\text{F}$ .

47.  $^{19}\text{F}(\gamma, p)^{18}\text{O}$   $Q_m = -7.994$

(1985KE03) have measured the yields of proton groups to  $^{18}\text{O}^*(0, 1.98)$  [and to unresolved states] for  $E_{\text{bs}}$  in the GDR range. See also (1978AJ03) and  $^{19}\text{F}$ .

48.  $^{19}\text{F}(n, d)^{18}\text{O}$   $Q_m = -5.770$

Angular distributions have been measured at  $E_n = 14$  to  $14.4$  MeV: see (1972AJ02). See also (1978AJ03) and  $^{20}\text{F}$ . Nuclear model calculations for  $E_n = 2$ – $20$  MeV are described in (1992ZH15).

Table 18.22:  $^{18}\text{O}$  states from  $^{19}\text{F}(t, \alpha\gamma)$  <sup>a</sup>

$E_x$ (keV)	$J^\pi$	$E_x$ (keV)	$J^\pi$
$1982.16 \pm 0.20$		$5530.5 \pm 0.6$	1, 2
$3555.07 \pm 0.45$		$6196.3 \pm 1.2$	1
$3634.50 \pm 0.40$		$6351.3 \pm 0.6$	1, 2
$3920.6 \pm 0.4$		$6404.4 \pm 1.2$	
$4456.1 \pm 0.5$		$6881.6 \pm 1.2$	0, (1)
$5098.5 \pm 1.2$		$7116.9 \pm 1.2$	
$5260.4 \pm 1.2$		7750	1, 2, 3, 4
$5336.4 \pm 0.6$		7980	1, 2, 3, 4, 5
$5377.8 \pm 1.2$		b	

<sup>a</sup> (1973OL02): See Table 18.10 for branching ratios and Table 18.9 for  $\tau_m$ . See also Table 18.10 in (1983AJ01).

<sup>b</sup> Alpha groups are also reported to  $^{18}\text{O}$  states with  $E_x = 7.60, 7.75, 7.84, 7.96, 8.02, 8.11, 8.19, 8.26, 8.39, 8.48, 8.64$  MeV ( $\pm 20$  keV) (1962HI06).

49.  $^{19}\text{F}(p, pp)^{18}\text{O}$   $Q_m = -7.994$

Experimental and theoretical studies of knockout reactions are reviewed in (1987VD1A).

50.  $^{19}\text{F}(d, ^3\text{He})^{18}\text{O}$   $Q_m = -2.500$

Many states of  $^{18}\text{O}$  ( $E_x < 14.6$  MeV) have been populated in this reaction: see Table 18.8 in (1978AJ03). [Comment: Note, however, density of states.] Analyzing powers for the ground-state transition are reported at  $E_d = 12.4$  MeV (1983EN02). See also (1983KI13).

51.  $^{19}\text{F}(t, \alpha)^{18}\text{O}$   $Q_m = 11.820$

See Table 18.22.

52.  $^{22}\text{Ne}(d, ^6\text{Li})^{18}\text{O}$   $Q_m = -8.192$

At  $E_d = 80$  MeV angular distributions have been measured for the  ${}^6\text{Li}$  groups to the ground state of  ${}^{18}\text{O}$  and to excited states at 1.98, 3.57, 5.10, 6.30, 7.8, 9.4 [ $\pm 0.04$ ] MeV (1984OE02) [see also for  $S_{\text{rel.}}$ ]. For the earlier work see (1983AJ01).

**<sup>18</sup>F**  
(Figs. 3 and 5)

GENERAL: See Table 18.23.

$$\begin{aligned}\mu_{1.12} &= +2.86 \pm 0.03 \text{ nm [see (1983AJ01)]} \\ Q_{1.12} &= 0.13 \pm 0.03 \text{ b [see (1983AJ01)].}\end{aligned}$$

1.  $^{18}\text{F}(\beta^+)^{18}\text{O}$   $Q_m = 1.655$

The positron decay is entirely to the ground state of  $^{18}\text{O}$  [ $J^\pi = 0^+$ ,  $T = 1$ ]; the half-life is  $109.77 \pm 0.05$  min [see Table 18.11 in (1972AJ02)];  $\log ft = 3.554$ . The fact that the  $\beta^+$  transition to  $^{18}\text{O}_{\text{g.s.}}$  is allowed fixes  $J^\pi = 1^+$  for  $^{18}\text{F}_{\text{g.s.}}$ .

The ratio  $\epsilon_K/\beta^+ = 0.030 \pm 0.002$ : see (1978AJ03, 1987AJ02). See also (1989SA1P, 1989KA1S).

The influence of meson exchange currents of the second kind is discussed in (1988SA12) and in (1989SA1H) which also considers the effects of neutrino mass. Charged-current ( $\nu_e, e^-$ ) reactions on  $^{18}\text{O}$  and the predicted effects on a proposed neutrino elastic scattering measurement of the Weinberg angle is discussed in (1988HA22).

2. (a)  $^{10}\text{B}(^9\text{Be}, n)^{18}\text{F}$   $Q_m = 14.455$

(b)  $^{11}\text{B}(^9\text{Be}, 2n)^{18}\text{F}$   $Q_m = 3.001$

See (1986CU02) for production cross sections of 0.94 MeV  $\gamma$ -rays.

3. (a)  $^{12}\text{C}(^6\text{Li}, d)^{16}\text{O}$   $Q_m = 5.687$   $E_b = 13.213$

(b)  $^{12}\text{C}(^6\text{Li}, \alpha)^{14}\text{N}$   $Q_m = 8.798$

(c)  $^{12}\text{C}(^6\text{Li}, ^6\text{Li})^{12}\text{C}$

Cross sections for these and other charged particle channels have been measured for  $E(^6\text{Li}) = 1.9$  to 36 MeV [see (1978AJ03, 1983AJ01)]. More recently, measurements of cross sections at  $E(^6\text{Li}) = 210$  MeV are reported in (1988NA02). Vector analyzing power measurements have been made at  $E(^6\text{Li}) = 150$  MeV (1987TA21, 1988TA08) and at  $E(^6\text{Li}) = 30$  MeV (1994RE01). for elastic scattering and at  $E(^6\text{Li}) = 30$  MeV (1988VAZY, 1989VA04) for inelastic scattering to  $^{12}\text{C}^*(4.43)$ . Neutron yields from  $^6\text{Li} + ^{12}\text{C}$  at  $E(^6\text{Li}) = 40$  MeV have been measured by (1987SC11).

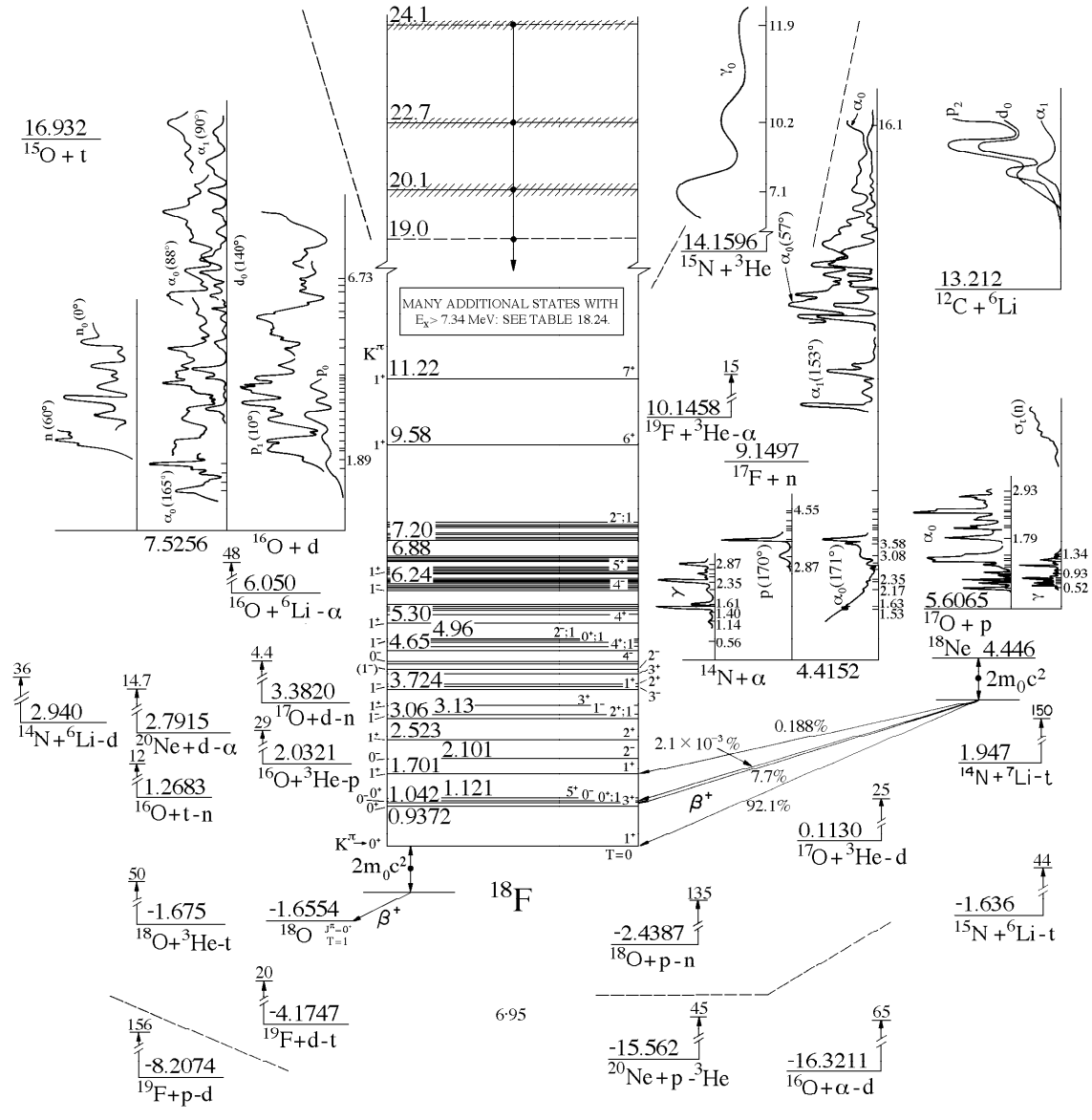

Fig. 3: Energy levels of  $^{18}\text{F}$ . For notation see Fig. 2.

Table 18.23:  $^{18}\text{F}$  – General

Reference	Description
Model Calculations	
1987LE1L	Low-lying non-normal parity states of $^{18}\text{O}$ & $^{18}\text{F}$ calculated in shell model + tensor force
1987SH10	Validity of M-3Y force equivalent G-matrix element for s-d shell nucl. struc. calcs.
1988BR11	Semi-empirical effective interactions for the 1s-0d shell
1989HJ03	Effective interactions through 3rd order for $A = 18$ nuclei with the Paris potential
1989TR18	2-nucleon and 4-nucleon clusters in light & heavy nuclei
1989ZH05	Evidence for unnatural parity-pairing correlations in some light nuclei
1990HJ03	Choice of single-particle potential & the convergence of the effective interaction
1990SK04	Study of $A = 18$ nuclei and the effective interaction in the sd shell
1990SK07	Effective interaction derived from the BAGEL approach
1992HJ01	Folded-diagram effective interactions with the Bonn meson-exchange potential model
1992JI04	Bonn potential used to evaluate energy spectra of some light sd-shell nuclei
1992WA22	Effective interactions for the 0p1s0d nuclear shell-model space
Special States	
Review:	
1989RA17	Compilation of exp. data on nuclear moments for ground & excited states of nucl.
Other Articles:	
1987LE1L	Non-normal parity states of $^{18}\text{O}$ & $^{18}\text{F}$ calculated in shell model + tensor force
1987MU16	Relativistic effects in the low-energy spectra of 1s0d-shell nuclei
1987SH10	Validity of M-3Y force equivalent G-matrix element for s-d shell nucl. struc. calcs.
1988ET01	Analysis of magnetic dipole transitions between sd-shell states
1989HJ03	Effective interactions through 3rd order for $A = 18$ nuclei with the Paris potential
1989ZH05	Evidence for unnatural parity-pairing correlations in some light nuclei
1990HJ01	3rd order number-conserving sets & effective interactions calc. with Bonn-Jülich potential
1990HJ03	Choice of single-particle potential & the convergence of the effective interaction
1990SK04	Study of $A = 18$ nuclei and the effective interaction in the sd shell
Electromagnetic	
Reviews:	
1988HE1E	Report on charge symmetry, charge independence, parity and time reversal invariance



Table 18.23:  $^{18}\text{F}$  – General – cont.

Reference	Description
-----------	-------------

Electromagnetic – cont.

- 1989MC1C** Nuclear tests of fundamental interactions  
**1989RA17** Compilation of exp. data on nuclear moments for ground & excited states of nucl.  
 Other articles:  
**1988ET01** Analysis of magnetic dipole transitions between sd-shell states  
**1988KA1U** Evaluation of the weak pion-nucleon vertex; predicts  $\gamma$ -asymmetry in  $^{18}\text{F}$   
**1993EN03** Strengths of  $\gamma$ -ray transitions in  $A = 5\text{--}44$  nuclei

Astrophysical

Reviews:

- 1987RA1D** Nuclear processes & accelerated particles in solar flares  
**1989WH1B** Abundance ratios as a function of metallicity  
**1990AR10** Nuclear reactions in astrophysics

Other articles:

- 1987GOZX** Measurement of  $^{21}\text{Ne}(p, \alpha)^{18}\text{F}$  & its astrophysical implications (A)  
**1988CA26** Analytic expressions for thermonuclear reaction rates involving  $Z \leq 14$  nuclei  
**1989JI1A** Nucleosynthesis inside thick accretion disks around massive black holes  
**1990TH1C** Explosive nucleosynthesis in SN 1987A: composition, radioactivities, neutron star mass

Applications

Review:

- 1989WO1B** Biomedical applications of particle accelerators (A)

Other articles:

- 1988HI1F** Design & uses of positron emission tomography target systems (A)  
**1988VO1D** Radionuclide production for positron emission tomography: accelerator choices (A)  
**1988VO1E** Water targetry for  $^{18}\text{F}$  prod. (calc. & exp. verification of beam heating & heat removal) (A)  
**1989AR1J** Production and acceleration of radioactive ion beams at Louvain-la-Neuve

Table 18.23:  $^{18}\text{F}$  – General – cont.

Reference	Description
Complex Reactions	
1987BU07	Projectile-like fragments from $^{20}\text{Ne} + ^{197}\text{Au}$ : counting simultaneously emitted neutrons
1987FE04	Single-nucleon transfer reactions induced by 376-MeV $^{17}\text{O}$ on $^{208}\text{Pb}$ (DWBA analysis)
1987HI05	Energy & linear-momentum dissipation in the fusion reaction $^{165}\text{Ho} + ^{20}\text{Ne}$ at 30 MeV/ $A$
1989SA10	Total cross sections of reactions induced by neutron-rich light nuclei
1990GL01	Structure phenomena in the orbiting $^{12}\text{C} + ^{24}\text{Mg}$ system
Hypernuclei	
1988MA1Q	Identification of one Glue-like mechanism of the $\Lambda$ -Hyperon in hypernuclei
1989BA92	Evaluation of hypernucleus production cross-sections in relativistic heavy-ion collisions
1989TA32	Schmidt diagrams & configuration mixing effects on hypernuclear magnetic moments
Symmetries and Fundamental Interactions	
1986ADZT	Parity and time-reversal violation in nuclei and atoms
1986HA1I	Fundamental interaction studies in nuclei
1988HE1C	Studies of symmetries and symmetry breaking using nuclei
1988HE1E	Status report on charge symmetry & charge independence
1989MC1C	Nuclear tests of fundamental interactions
Other Topics	
Review	
1989AJ1A	Summary of recent work involving light nuclei (Sec. 4.2 covers $A = 18$ )
Other articles:	
1987MU16	Relativistic effects in the low-energy spectra of 1s <sub>0</sub> d-shell nuclei
1988KA1U	Evaluation of the weak pion-nucleon vertex; predicts $\gamma$ -asymmetry in $^{18}\text{F}$

Table 18.23:  $^{18}\text{F}$  – General – cont.

Reference	Description
Other Topics – cont.	
1988TR02	Interacting boson scheme for light nuclei
1989GE10	Threshold pion-nucleus amplitudes as predicted by current algebra
1989ZH05	Evidence for unnatural parity-pairing correlations in some light nuclei
1990HJ01	3rd order number-conserving sets & effective interactions calc. with Bonn-Jülich potential
1990KA1F	Theoretical aspects of nuclear parity violation
1990SK04	Study of $A = 18$ nuclei and the effective interaction in the sd shell
1990SK07	Effective interaction derived from the BAGEL approach

### Ground State Properties

Review:

1989RA17 Compilation of exp. data on nuclear moments for ground & excited states of nucl.

Other articles:

1989SA10 Total cross sections of reactions induced by neutron-rich light nuclei

1989TR18 2-nucleon and 4-nucleon clusters in light & heavy nuclei

1991UE01 Unitary pole approx. for Coulomb+Yamaguchi potential used for 3-body bound-state calc.

---

(A) denotes that only an abstract is available for this reference.

The cross section for the isospin-forbidden  $\alpha_1$  group [to  $^{14}\text{N}^*(2.31), 0^+, T = 1$ ] is 1 to 2% of the cross section of the allowed  $\alpha_0$  and  $\alpha_2$  groups for  $E(^6\text{Li}) = 3.2$  to 6 MeV while for 9 to 14 MeV it varies from 0.4 to 1.8%. At 20 MeV, the  $\alpha_1$  yield is 0.02% of the allowed yield. Structures are reported at  $E(^6\text{Li}) = 11.0$  and 13.0 MeV in the  $\alpha_0$  yield, at 11.5 and 13.0 MeV in the  $\alpha_1$  yield and at  $\approx 11.7$  and 12.8 MeV in the  $\alpha_2$  yield. A resonance is also reported in the  $\alpha_1$  yield at  $E(^6\text{Li}) = 4.2$  MeV:  $E_x = 15.99 \pm 0.02$  MeV,  $\Gamma_{\text{c.m.}} = 290 \pm 30$  keV,  $J^\pi = 2^+$  (one-level BW fit). It is suggested that this resonance is due to  $2^+$  states with  $T = 0$  and 1 which are unresolved. Cross sections for populating  $^{16}\text{O}^*(8.87, 10.36, 11.08, 11.10)$  are reported by (1981GL02).

The excitation functions for the  $^6\text{Li}$  ions to  $^{12}\text{C}^*(0, 4.43)$  show a single isolated structure at  $E(^6\text{Li}) = 22.8$  MeV, in the range 20–36 MeV, with  $\Gamma \approx 0.8$  MeV. It is unlikely to be due to an isolated state in  $^{18}\text{F}$ . Analyzing power measurements are reported for many deuteron and  $\alpha$  groups and for elastically scattered  $^6\text{Li}$  ions at  $E(^6\text{Li}) = 20$  MeV. VAP measurements for elastic

scattering are also reported at  $E_d = 9.0$  and  $19.2$  MeV (1983RU09) and at  $150$  MeV (1986KA1C, 1986TA1B).

For fusion studies see (1982DE30, 1987PA12). For references to earlier work and for additional comments see (1978AJ03, 1983AJ01, 1987AJ02),  $^{12}\text{C}$  in (1985AJ01),  $^{14}\text{N}$  in (1986AJ01), and  $^{16}\text{O}$  in (1986AJ04, 1993TI07).

Table 18.24: Energy levels of  $^{18}\text{F}$  <sup>a</sup>

$E_x$ (MeV $\pm$ keV)	$J^\pi; T$	$K^\pi$	$\tau$ or $\Gamma_{\text{c.m.}}$	Decay	Reactions
0	$1^+; 0$	$0^+$	$\tau_{1/2} = 109.77 \pm 0.05$ min	$\beta^+$	1, 4, 5, 6, 9, 10, 12, 13, 15, 21, 23, 24, 25, 29, 31, 34, 35, 36, 37, 38, 40, 41, 42, 43, 44
$0.93720 \pm 0.06$	$3^+; 0$	$0^+$	$\tau_m = 67.6 \pm 2.5$ ps ( $g = +0.56 \pm 0.05$ )	$\gamma$	2, 6, 9, 10, 13, 21, 23, 25, 30, 31, 35, 36, 38, 40, 41, 42, 44
$1.04155 \pm 0.08$	$0^+; 1$		$\tau_m = 2.55 \pm 0.45$ fs	$\gamma$	6, 9, 21, 25, 30, 31, 34, 35, 37, 38, 40, 42, 43
$1.08054 \pm 0.12$	$0^-; 0$	$0^-$	$\tau_m = 27.5 \pm 1.9$ fs	$\gamma$	6, 9, 10, 21, 25, 35, 37, 38, 40, 41, 42, 44
$1.12136 \pm 0.15$	$5^+; 0$	$0^+$	$\tau_m = 234 \pm 10$ ns ( $\mu = +2.86 \pm 0.03$ nm) ( $Q = 0.13 \pm 0.036$ b)	$\gamma$	5, 6, 9, 10, 13, 14, 21, 22, 25, 30, 31, 32, 35, 37, 40, 42, 44
$1.70081 \pm 0.18$	$1^+; 0$	$1^+$	$\tau_m = 955 \pm 27$ fs	$\gamma$	6, 10, 21, 25, 34, 35, 40, 42, 43, 44
$2.10061 \pm 0.10$	$2^-; 0$	$0^-$	$\tau_m = 5.1 \pm 0.5$ ps	$\gamma$	6, 10, 13, 21, 23, 25, 35, 40, 42, 44
$2.52335 \pm 0.18$	$2^+; 0$	$1^+$	$\tau_m = 590 \pm 24$ fs	$\gamma$	6, 10, 21, 25, 30, 31, 40, 42
$3.06184 \pm 0.18$	$2^+; 1$		$\tau_m < 1.2$ fs	$\gamma$	6, 21, 25, 30, 31, 35, 38, 40, 42, 43
$3.13387 \pm 0.15$	$1^-; 0$	$1^-$	$\tau_m = 0.39 \pm 0.02$ ps	$\gamma$	6, 10, 21, 25, 35, 38, 40, 42
$3.3582 \pm 1.0$	$3^+; 0$	$1^+$	$\tau_m = 0.44 \pm 0.03$ ps	$\gamma$	6, 10, 21, 35, 40, 42, 44
$3.72419 \pm 0.22$	$1^+; 0$		$\tau_m = 2.7^{+4.1}_{-2.7}$ fs	$\gamma$	6, 10, 21, 23, 25, 31, 34, 35, 40, 42, 44
$3.79149 \pm 0.22$	$3^-; 0$	$1^-$	$\tau_m = 1.91 \pm 0.13$ ps	$\gamma$	5, 10, 21, 23, 25, 35, 40, 42, 44
$3.83917 \pm 0.22$	$2^+; 0$		$\tau_m = 19.0 \pm 2.7$ fs	$\gamma$	6, 10, 21, 23, 25, 30, 35, 40, 42, 44
$4.11590 \pm 0.25$	$3^+; 0$		$\tau_m = 91 \pm 22$ fs	$\gamma$	6, 10, 21, 23, 25, 30, 31, 35, 40, 42, 44
$4.2258 \pm 0.7$	$2^-; 0$	( $1^-$ )	$\tau_m = 110 \pm 15$ fs	$\gamma$	6, 10, 21, 23, 35, 40, 42, 44
$4.36015 \pm 0.26$	$1^+; 0$		$\tau_m = 27 \pm 10$ fs	$\gamma$	10, 21, 25, 34, 35, 40, 42, 44
$4.3981 \pm 0.7$	$4^-; 0$	$0^-$	$\tau_m = 58 \pm 12$ fs	$\gamma$	6, 10, 13, 14, 21, 35, 40, 42, 44
$4.652 \pm 2$	$4^+; 1$		$\tau_m < 10$ fs	$\gamma$	6, 21, 24, 30, 31, 35, 40, 42
$4.753 \pm 3$	$0^+; 1$			$\gamma$	21, 35, 38, 40, 42, 44
$4.8483 \pm 0.5$	$5^-; 0$	$1^-$	$\tau_m = 5.2 \pm 0.9$ ps	$\gamma$	5, 23
$4.860 \pm 2$	$1^-; 0$		$\tau_m = 66 \pm 18$ fs	$\gamma, \alpha$	6, 21, 40, 42, 44
$4.9636 \pm 0.8$	$2^+; 1$		$\tau_m < 4$ fs	$\gamma$	6, 21, 30, 40, 42
$5.2976 \pm 1.5$	$4^+; 0$	$1^+$	$\tau_m = 30 \pm 5$ fs	$\gamma, \alpha$	6, 9, 10, 11, 21, 40, 42

Table 18.24: Energy levels of  $^{18}\text{F}$  <sup>a</sup> (continued)

$E_x$ (MeV $\pm$ keV)	$J^\pi; T$	$K^\pi$	$\tau$ or $\Gamma_{\text{c.m.}}$	Decay	Reactions
5.502 $\pm$ 2	3 <sup>(-)</sup> ; 0		$\tau_m = 63 \pm 25$ fs	$\gamma, \alpha$	6, 10, 21, 40, 42
5.60338 $\pm$ 0.27	1 <sup>+</sup>		$\Gamma = 43.3 \pm 1.6$ eV	$\gamma, \alpha$	6, 8, 25, 40, 42, 44
5.60486 $\pm$ 0.28	1 <sup>-</sup> ; 0 + 1		$\Gamma < 1.2$ keV	$\gamma, \alpha$	6, 8, 10, 21, 25, 40, 42, 44
5.67257 $\pm$ 0.32 <sup>d</sup>	1 <sup>-</sup> ; 0 + 1		$\Gamma < 0.8$ keV	$\gamma, \alpha$	6, 8, 10, 21, 25, 40, 42, 44
5.786 $\pm$ 2.4	2 <sup>-</sup> ; 0		$\tau_m = 15 \pm 10$ fs	$\gamma, \alpha$	6, 21, 40, 42, 44
6.0964 $\pm$ 1.1	4 <sup>-</sup> ; 0	1 <sup>-</sup>	$\Gamma = 0.24 \pm 0.03$ keV	$\gamma, p, \alpha$	6, 10, 21, 25, 29, 40, 42, 44
6.108 $\pm$ 3	(1 <sup>+</sup> ); 0		$\Gamma = 0.034 \pm 0.003$ keV	$\gamma, p, \alpha$	6, 8, 21, 23, 29, 42, 44
6.13647 $\pm$ 0.33	0 <sup>+</sup> ; 1		$\Gamma \leq 1$ keV	$\gamma, p$	21, 25, 27, 42, 44
6.1632 $\pm$ 0.9	3 <sup>+</sup> ; 1		$\Gamma = 14 \pm 0.5$ keV	$\gamma, p, \alpha$	21, 25, 27, 42, 44
6.2404 $\pm$ 0.8	3 <sup>-</sup> ; 0 + 1		$\Gamma = 0.19 \pm 0.03$ keV	$\gamma, p, \alpha$	6, 21, 25, 27, 29, 42
6.242 $\pm$ 3	3 <sup>-</sup> ; 0 + 1		$\Gamma = 0.18 \pm 0.04$ keV	$\gamma, p, \alpha$	6, 8, 21, 25, 29, 42
6.262 $\pm$ 2.5	1 <sup>+</sup> ; 0		$\Gamma = 0.60 \pm 0.12$ keV	$\gamma, p, \alpha$	6, 8, 10, 21, 29, 34, 42
6.2832 $\pm$ 0.9	2 <sup>+</sup> ; 1		$\Gamma = 10.0 \pm 0.5$ keV	$\gamma, p, \alpha$	21, 25, 27, 29
6.3105 $\pm$ 0.8	3 <sup>+</sup> ; 0		$\Gamma = 0.95 \pm 0.14$ keV	$\gamma, p, \alpha$	6, 21, 25, 27, 29, 44
6.3855 $\pm$ 1.7	2 <sup>+</sup> ; 0 + 1		$\Gamma = 0.49 \pm 0.09$ keV	$\gamma, p, \alpha$	6, 21, 25, 29, 42
6.4849 $\pm$ 1.5	3 <sup>+</sup> ; 0		$\Gamma = 0.40 \pm 0.10$ keV	$\gamma, p, \alpha$	6, 21, 25, 29, 42, 44
6.5670 $\pm$ 1.5	5 <sup>+</sup> ; 0	1 <sup>+</sup>	$\Gamma = 0.56 \pm 0.13$ keV	$\gamma, p, \alpha$	6, 8, 9, 10, 11, 21, 29, 42
6.633 $\pm$ 10	1		$\Gamma = 80 \pm 2$ keV	$p, \alpha$	29, 42
6.6437 $\pm$ 0.8	2 <sup>-</sup> ; 1		$\Gamma = 0.60 \pm 0.07$ keV	$\gamma, p, \alpha$	6, 7, 21, 25, 29
6.647 $\pm$ 4	1 <sup>-</sup>		$\Gamma = 91 \pm 4$ keV	$p, \alpha$	8, 10, 29
6.777 $\pm$ 1.4	4 <sup>+</sup> ; 0		$\Gamma = 9.2 \pm 1.0$ keV	$\gamma, p, \alpha$	21, 25, 27, 29, 42
6.8031 $\pm$ 1.5	1 <sup>+</sup> , 2, 3 <sup>+</sup> ; 0		$\Gamma \leq 2$ keV	$\gamma, p$	10, 21, 25, 27, 42
6.809 $\pm$ 5	2 <sup>-</sup>		$\Gamma = 88 \pm 2$ keV	$p, \alpha$	7, 8, 29
6.811	(2 <sup>+</sup> )		$\Gamma = 3.0 \pm 0.5$ keV	$p, \alpha$	29
6.857 $\pm$ 10	(3 <sup>-</sup> )		$\Gamma = 5.0 \pm 1.0$ keV	$p, \alpha$	29, 42
6.8774 $\pm$ 1.7	3, 4 <sup>-</sup> ; 0		$\Gamma \leq 2$ keV	$\gamma, p, \alpha$	21, 25, 29
7.201 $\pm$ 2	(4 <sup>+</sup> ); 0		$\Gamma = 6.5$ keV	$p, \alpha$	8, 20, 42
7.247 $\pm$ 2	(1 <sup>+</sup> ); 0		$\Gamma = 46.5$ keV	$p, \alpha$	8, 29
7.291 $\pm$ 2	3 <sup>-</sup>		$\Gamma = 38$ keV	$p, \alpha$	7, 8, 27, 29
7.315 $\pm$ 4	(3 <sup>-</sup> ; 0)		$\Gamma = 52$ keV	$p, \alpha$	29, 40
7.336 $\pm$ 2	1 <sup>-</sup> ; 1		$\Gamma = 16 \pm 2$ keV	$\gamma, p$	25, 27
7.406 $\pm$ 2	1 <sup>+</sup>		$\Gamma = 14.6 \pm 1.4$ keV	$p$	27
7.447 $\pm$ 10			$\Gamma = 140$ keV	$p, \alpha$	29, 31
7.454 $\pm$ 2	1 <sup>-</sup>		$\Gamma = 6$ keV	$p$	27
7.478 $\pm$ 2	(2)		$\Gamma = 12 \pm 3$ keV	$\gamma, p, \alpha$	25, 27, 29
(7.485 $\pm$ 2)	(1 <sup>-</sup> )		$\Gamma = 32$ keV	$p$	27

Table 18.24: Energy levels of  $^{18}\text{F}$  <sup>a</sup> (continued)

$E_x$ (MeV $\pm$ keV)	$J^\pi; T$	$K^\pi$	$\tau$ or $\Gamma_{\text{c.m.}}$	Decay	Reactions
7.506 $\pm$ 2	4 <sup>-</sup>		$\Gamma = 12 \pm 2$ keV	p, $\alpha$	27, 29
7.513 $\pm$ 2			$\Gamma < 4$ keV	$\gamma$ , p	25
7.528 $\pm$ 2	2 <sup>-</sup> ; 1		$\Gamma = 16.5 \pm 3.0$ keV	$\gamma$ , p, $\alpha$	25, 27, 29
7.532 $\pm$ 5			$\Gamma = 75$ keV	p, $\alpha$	27, 29
7.555 $\pm$ 2	(1 <sup>-</sup> )		$\Gamma = 30$ keV	p	27
7.584 $\pm$ 2			$\Gamma = 9 \pm 2$ keV	$\gamma$ , p, $\alpha$	25, 27, 29
7.685 $\pm$ 2	3 <sup>+</sup> , 4 <sup>+</sup>		$\Gamma = 36 \pm 4$ keV	p, $\alpha$	27, 29
7.729 $\pm$ 4	$\geq 1$		$\Gamma = 66 \pm 5$ keV	p, $\alpha$	27, 29
7.763 $\pm$ 4			$\Gamma = 70$ keV	p	27
7.878 $\pm$ 3	$\geq 2$		$\Gamma = 20$ keV	p, $\alpha$	27, 29
7.899 $\pm$ 2	(2 <sup>-</sup> )		$\Gamma = 38$ keV	p, $\alpha$	7, 8, 29
7.941 $\pm$ 12	(1 <sup>+</sup> )		$\Gamma = 112$ keV	p, $\alpha$	7, 8, 29
8.064 $\pm$ 6	$\geq 4$		$\Gamma = 60$ keV	p, $\alpha$	27, 29
8.115 $\pm$ 8			$\Gamma = 96$ keV	p	27
8.209 $\pm$ 2	2 <sup>-</sup>		$\Gamma = 52$ keV	p, $\alpha$	27, 29
8.238 $\pm$ 2	4 <sup>+</sup>		$\Gamma = 20$ keV	p	27
9.02	(5 <sup>-</sup> ; 1)				31
9.207 $\pm$ 15 <sup>b</sup>	3, 4 <sup>-</sup> ; 0			p, d, $\alpha$	16, 17, 18
9.50	2, 3 <sup>+</sup> ; 0			n, d, $\alpha$	16, 18
9.58 $\pm$ 20 <sup>c</sup>	6 <sup>+</sup>	1 <sup>+</sup>		d, $\alpha$	9, 10, 11, 22, 31
10.58 $\pm$ 50					11
11.22 $\pm$ 30	7 <sup>+</sup>	1 <sup>+</sup>		d, $\alpha$	9, 10, 11
12.75	(6 <sup>-</sup> ; 1)				31
13.83	4 <sup>-</sup> , 5 <sup>+</sup>		$\Gamma = 60$ keV	d, $\alpha$	18
14.02	4 <sup>-</sup> , 5 <sup>+</sup>		$\Gamma = 60$ keV	d, $\alpha$	18
14.10	4 <sup>-</sup> , 5 <sup>+</sup>		$\Gamma = 60$ keV	d, $\alpha$	18
14.18 $\pm$ 40	(8 <sup>+</sup> )	(1 <sup>+</sup> )		d, $\alpha$	9, 10, 11
14.65	(7 <sup>+</sup> )				31
15.09	4 <sup>-</sup> , 5 <sup>+</sup>			d, $\alpha$	18
15.34	5 <sup>+</sup> , 6 <sup>-</sup>			d, $\alpha$	18
15.79 $\pm$ 100	(6 <sup>-</sup> ; 1)				11, 31
16.07	4 <sup>-</sup> , 5 <sup>+</sup>		$\Gamma = 220$ keV	d, $\alpha$	18
16.72	4 <sup>-</sup> , 5 <sup>+</sup>		$\Gamma = 60$ keV	d, $\alpha$	18
17.43	4 <sup>-</sup> , 5 <sup>+</sup> , 6 <sup>-</sup>		$\Gamma = 70$ keV	d, $\alpha$	18
18.62 $\pm$ 120					11
(19.00 $\pm$ 150)			$\Gamma = (500 \pm 150)$ keV	$\gamma$ , $^3\text{He}$	12

Table 18.24: Energy levels of  $^{18}\text{F}$  <sup>a</sup> (continued)

$E_x$ (MeV $\pm$ keV)	$J^\pi; T$	$K^\pi$	$\tau$ or $\Gamma_{\text{c.m.}}$	Decay	Reactions
20.1 $\pm$ 200	(2 <sup>-</sup> ; 1)		$\Gamma = 1600 \pm 100$ keV	$\gamma, ^3\text{He}$	12
22.7 $\pm$ 200	(2 <sup>-</sup> ; 1)		$\Gamma = 1200 \pm 100$ keV	$\gamma, ^3\text{He}$	12
(24.1 $\pm$ 200)			$\Gamma = (1400 \pm 300)$ keV	$\gamma, ^3\text{He}$	12

<sup>a</sup> See also Table 18.25 for radiative transitions and 18.26 for  $\tau_m$ .

<sup>b</sup> Uncertainty estimated by evaluators.

<sup>c</sup> For other states with  $E_x < 9.6$  MeV see footnote <sup>e</sup> in Table 18.17 of (1978AJ03) and Table 18.27 here. For other states with  $10.0 < E_x < 19.6$  MeV see Table 18.27 here, and Tables 18.14 and 18.16 in (1978AJ03). These two tables in (1978AJ03) display the states deduced from the yields of the isospin-forbidden  $\alpha_1$  groups in  $^{14}\text{N} + \alpha$  and  $^{16}\text{O} + d$ , respectively. (1976CH24) reports 151 isospin-mixed natural-parity states with  $10.4 < E_x < 17.5$  MeV [ $^{14}\text{N}(\alpha, \alpha_1)$ ] and (1973JO13) reports 138 such states with  $9.2 < E_x < 19.4$  MeV [ $^{16}\text{O}(d, \alpha_1)$ ] of which 16 have  $E_x > 17.5$  MeV. In the region  $10.4 < E_x < 20.8$  MeV some 167 states with mixed isospin and natural parity have been reported. See also reaction 29.

<sup>d</sup> (1989BO01).

$$4. \ ^{12}\text{C}(^9\text{Be}, t)^{18}\text{F} \quad Q_m = -4.475$$

Angular distributions are reported at  $E(^9\text{Be}) = 12$  to 27 MeV to  $^{18}\text{F}_{\text{g.s.}}$  and to the unresolved states at 1 MeV: see (1983AJ01). For excitation functions see (1982HU06, 1983JA09).

$$5. \ ^{12}\text{C}(^{11}\text{B}, \alpha n)^{18}\text{F} \quad Q_m = -2.701$$

For  $^{18}\text{F}^*(4.85)$  [5<sup>-</sup>;  $T = 0$ ]  $\tau_m = 5.2 \pm 0.9$  ps. The E1 strength is  $(3.4 \pm 0.6) \times 10^{-6}$  W.u. for the transition to  $^{18}\text{F}^*(1.12)$  [5<sup>+</sup>;  $T = 0$ ] and the E2 strength is  $14.8 \pm 2.6$  W.u. for that to  $^{18}\text{F}^*(3.79)$  [3<sup>-</sup>; 0]. The latter strength, which is that of a highly collective transition, corresponds to a quadrupole moment  $Q_0 = 395 \pm 35$  mb and suggests that  $^{18}\text{F}^*(4.85)$  is the 5<sup>-</sup> state of a (strongly decoupled)  $K^\pi = 1^-$  band (1982KO24). See also Tables 18.14 and 18.15.

$$6. \ ^{14}\text{N}(\alpha, \gamma)^{18}\text{F} \quad Q_m = 4.415$$

The non-resonant  $S$ -factor for this reaction is  $S \approx 0.7$  MeV  $\cdot$  b: see (1978AJ03). A number of resonances have been observed for  $E_\alpha < 3$  MeV: see Table 18.27. Studies of these, principally

by the Toronto and Queen's groups [see references in (1978AJ03, 1983AJ01)] in conjunction with work on  $^{14}\text{N}(\alpha, \alpha)$ ,  $^{16}\text{O}(^3\text{He}, \text{p})$ ,  $^{17}\text{O}(\text{p}, \gamma)$  and  $^{17}\text{O}(\text{p}, \alpha)$  [see Tables 18.29, 18.30, 18.31] have led to the determination of branching ratios, mixing ratios and widths (Table 18.25), lifetimes (Table 18.26) and the  $E_x$ ,  $J^\pi$  and  $K^\pi$  assignments for  $^{18}\text{F}$  states with  $E_x < 6.9$  MeV. The reader is referred to the series of papers by the Toronto group for the most complete and definitive arguments on the parameters of the low-lying states of  $^{18}\text{F}$ .

A recent measurement reported in (1989BO01) determines a value  $E_x = 5672.57 \pm 0.32$  keV for the first  $^{18}\text{F}$  level above the proton threshold. This level is important for calculating the rate of  $^{17}\text{O}$  destruction during hydrogen burning in stars.

No evidence is seen for the excitation of the (forbidden) state at  $E_x = 4.753$  MeV [ $J^\pi = 0^+$ ,  $T = 1$ ] (1981LE1A, 1983LE08). See also (1987AJ02), and see the tables of reaction rates (1988CA26) and the reviews of (1989KA24, 1989WH1B, 1989TH1C).

$$7. \ ^{14}\text{N}(\alpha, \text{p})^{17}\text{O}$$

$$Q_m = -1.192$$

$$E_b = 4.415$$

Table 18.25: Radiative decays in  $^{18}\text{F}$  <sup>a</sup>

$E_i$ (MeV)	$J_i^\pi$	$E_f$ (MeV)	Branch (%)	Widths and mixing ratios
0.94	$3^+; 0$	0	100	
1.04	$0^+; 1$	0	100	
1.08	$0^-; 0$	0	100	
1.12	$5^+; 0$	0.94	100	
1.70	$1^+; 0$	0	$29.8 \pm 1.3$	
		1.04	$70.2 \pm 1.3$	
2.10	$2^-; 0$	0	$38 \pm 1$	$\Gamma_\gamma = (4.6 \pm 2.2) \times 10^{-5}$ eV
		0.94	$31 \pm 1$	$\Gamma_\gamma = (4.0 \pm 1.9) \times 10^{-5}$ eV
		1.08	$31 \pm 1$	
2.52	$2^+; 0$	0	$74.9 \pm 1.8$	$\delta = 3.0 \pm 1.0$
		0.94	$21.5 \pm 1.2$	$\delta = -(1.5 \pm 0.6)$
		1.70	$3.9 \pm 0.6$	$\delta = 0.94 \pm 0.4$
3.06	$2^+; 1$	0	$23.2 \pm 0.8$	
		0.94	$76.7 \pm 0.8$	
		1.04	$0.11 \pm 0.03$	
3.13	$1^-; 0$	0	$39 \pm 2$	$\delta = +(0.07 \pm 0.05)$
				$\Gamma_\gamma = (5.7 \pm 2) \times 10^{-4}$ eV



Table 18.25: Radiative decays in  $^{18}\text{F}$  <sup>a</sup> (continued)

$E_i$ (MeV)	$J_i^\pi$	$E_f$ (MeV)	Branch (%)	Widths and mixing ratios
3.36	$3^+; 0$	1.04	$34 \pm 2$	$\Gamma_\gamma = (7.3 \pm 2.7) \times 10^{-4} \text{ eV}$
		1.08	$25 \pm 2$	$\Gamma_\gamma = (4.8 \pm 1.8) \times 10^{-4} \text{ eV}$
		1.70	$2.0 \pm 0.5$	$\delta = +(0.22 \pm 0.15)$
		0	$45 \pm 5$	
		0.94	$9 \pm 3$	
		1.70	$40 \pm 4$	
		2.10	$< 3$	
3.72	$1^+; 0$	2.52	$6 \pm 3$	$\delta = -0.4_{-0.5}^{+0.3}$
		0	$5 \pm 2$	
3.79	$3^-; 0$	1.04	$91 \pm 2$	$\Gamma_\gamma = (1.3 \pm 0.2) \times 10^{-3} \text{ eV}^c$
		3.06	$4 \pm 2$	
3.84	$2^+; 0$	2.10	$68 \pm 4$	$\delta = -(0.22 \pm 0.06)$
		2.52	$2.2 \pm 1.1$	
		3.06	$30 \pm 3$	$\delta = -(0.09 \pm 0.09)$
4.12	$3^+; 0$	0	$38 \pm 2$	$\delta = -(1.8 \pm 0.5)$
		0.94	$8.9 \pm 1.4$	$\delta = -(0.3 \pm 0.3)$
		1.70	$3.0 \pm 1.0$	
		3.06	$50 \pm 3$	$\delta = -(0.1 \pm 0.3)$
4.23	$2^-; 0$	0	$5 \pm 3$	$\delta = +0.06 \pm 0.07$
		3.06	$95 \pm 3$	$\delta = 0.15 \pm 0.15$
4.36	$1^+$	0.94	$49 \pm 3$	$\delta = 0.0 \pm 0.2$
		1.08	$3.2 \pm 1.0$	
		1.70	$9.3 \pm 1.2$	
		2.10	$15 \pm 5$	
		3.13	$0.9 \pm 0.6$	
		3.06	100	
		3.06	100	
4.40	$4^-; 0$	0.94	$13 \pm 4$	$\delta = -(0.2 \pm 0.3)$
		1.12	$60 \pm 6$	$\delta = -(0.2 \pm 0.2)$
4.65	$4^+; 1$	2.10	$27 \pm 3$	
		0.94	$17 \pm 3$	

Table 18.25: Radiative decays in  $^{18}\text{F}$  <sup>a</sup> (continued)

$E_i$ (MeV)	$J_i^\pi$	$E_f$ (MeV)	Branch (%)	Widths and mixing ratios
		1.12	$83 \pm 3$	$\delta = 0.15 \pm 0.15$
4.75	$0^+; 1$	0	$92 \pm 4$	
		1.70	$8 \pm 4$	
4.85 <sup>b</sup>	$5^-; 0$	1.12	$65 \pm 4$	
		3.79	$35 \pm 4$	
4.86	$1^-; 0$	1.04	$65 \pm 11$	
		1.08	$8 \pm 6$	
		3.06	$23 \pm 7$	$\delta = -(0.4 \pm 0.4)$
		3.13	$4 \pm 3$	
4.96	$2^+; 1$	0	100	$\delta = 1.2 \pm 0.7$
5.30	$4^+; 0$	0.94	$9 \pm 2$	$\delta = -(0.3 \pm 0.1)$
		1.12	$7 \pm 2$	$\delta = -(1.1 \pm 0.5)$
		2.52	$78 \pm 3$	$\Gamma_\gamma = 1.2 \pm 0.4 \times 10^{-2} \text{ eV}^c$
		3.36	$5 \pm 1$	$\delta = 2.5 \pm 0.8$
		4.65	$1.3 \pm 0.3$	
5.50	$3^{(-)}; 0$	3.06	100	$\Gamma_\gamma = 2.1 \pm 0.7 \times 10^{-3} \text{ eV}^c$
5.603	$1^+$	0	$16.7 \pm 2.3$	$\Gamma_\gamma = 0.485 \pm 0.046 \text{ eV}^c$
		1.04	$3.8 \pm 1.2$	
		3.06	$79.5 \pm 5.9$	
5.605	$1^-; 0 + 1$	0	$6.7 \pm 1.2$	
		1.04	$4.2 \pm 0.8$	
		1.08	$54.3 \pm 3.1$	$\Gamma_\gamma = 0.87 \pm 0.07 \text{ eV}^c$
		3.06	$2.6 \pm 1.4$	
		3.13	$32.2 \pm 2.5$	$\delta = -0.05 \pm 0.02$
5.67	$1^-; 0 + 1$	0	$6.2 \pm 0.4$	$\delta = -0.01 \pm 0.04$
		1.04	$8.1 \pm 0.7$	
		1.08	$52 \pm 3$	$\Gamma_\gamma = 0.46 \pm 0.06 \text{ eV}^c$
		1.70	$0.8 \pm 0.3$	
		2.10	$0.4 \pm 0.2$	
		3.06	$4.0 \pm 0.4$	$\delta = 0.04 \pm 0.06$
		3.13	$28.5 \pm 2.0$	$\delta = +0.10 \pm 0.03$

Table 18.25: Radiative decays in  $^{18}\text{F}$  <sup>a</sup> (continued)

$E_i$ (MeV)	$J_i^\pi$	$E_f$ (MeV)	Branch (%)	Widths and mixing ratios
5.79	$2^-; 0$	0.94	$40 \pm 8$	$\Gamma_\gamma = 5.1 \pm 1.0 \times 10^{-2} \text{ eV}^c$
		1.08	$60 \pm 8$	
6.10	$4^-; 0$	0.94	$4.9 \pm 0.9$	
		1.12	$55 \pm 3$	
		2.10	$27 \pm 2$	
		3.79	$1.4 \pm 0.3$	
		4.12	$1.8 \pm 0.3$	
		4.40	$0.7 \pm 0.3$	
6.10	$(1^+); 0$	4.65	$8.7 \pm 0.7$	
		0	$24 \pm 3$	
		0.94	$11 \pm 3$	
		2.10	$20 \pm 6$	
		3.06	$45 \pm 5$	
6.14	$0^+; 1$	0	$50 \pm 3$	
		1.70	$12 \pm 2$	
		3.72	$36 \pm 3$	
		4.36	$2.1 \pm 0.4$	
		5.603	$0.19 \pm 0.02$	
6.16	$3^+; 1$	0	$0.2 \pm 0.2$	$\Gamma_\gamma = 0.96 \pm 0.26 \text{ eV}^c$
		0.94	$51 \pm 3$	
		1.12	$1.0 \pm 0.1$	
		2.52	$5.5 \pm 0.4$	
		3.06	$1.3 \pm 0.3$	
		3.79	$11.6 \pm 1.3$	
		3.84	$25.0 \pm 1.6$	
		4.12	$1.5 \pm 0.3$	
		4.23	$0.9 \pm 0.3$	
		4.40	$2.0 \pm 0.2$	
6.240	$3^-; 0 + 1$	0.94	$4.6 \pm 0.3$	$\Gamma_\gamma = 0.8 \pm 0.11 \text{ eV}^c$
		2.10	$71.5 \pm 3.0$	
		3.36	$1.1 \pm 0.4$	

Table 18.25: Radiative decays in  $^{18}\text{F}$  <sup>a</sup> (continued)

$E_i$ (MeV)	$J_i^\pi$	$E_f$ (MeV)	Branch (%)	Widths and mixing ratios
6.242	$3^-; 0+1$	3.79	$10.6 \pm 0.5$	$\Gamma_\gamma = 0.73 \pm 0.11 \text{ eV}^c$
		3.84	$1.0 \pm 0.2$	
		4.12	$0.5 \pm 0.2$	
		4.23	$7.8 \pm 0.4$	
		4.40	$2.9 \pm 0.3$	
		0.94	$4.1 \pm 0.3$	
		2.10	$71.2 \pm 3.0$	
		3.36	$0.8 \pm 0.3$	
		3.79	$11.6 \pm 0.6$	
		3.84	$0.9 \pm 0.2$	
		4.12	$1.1 \pm 0.4$	
		4.23	$8.2 \pm 0.4$	
		4.40	$2.1 \pm 0.3$	
6.26	$1^+; 0$	0	(100)	$\Gamma_\gamma = 1.8 \pm 0.5 \text{ eV}^c$
6.28	$2^+; 1$	0	$0.3 \pm 0.1$	
		0.94	$67 \pm 3$	
		1.04	$1.3 \pm 0.1$	
		1.70	$5.7 \pm 0.6$	
		2.10	$1.2 \pm 0.3$	
		2.52	$0.3 \pm 0.2$	
		3.13	$0.7 \pm 0.3$	
		3.36	$2.3 \pm 0.3$	
		3.72	$1.4 \pm 0.5$	
		3.84	$15.8 \pm 1.4$	
		4.12	$3.9 \pm 0.2$	
		4.36	$0.5 \pm 0.4$	
6.31	$3^+; 0$	0	$4.0 \pm 0.7$	$\Gamma_\gamma = 0.17 \pm 0.04 \text{ eV}^c$
		0.94	$10.6 \pm 1.0$	
		1.70	$3.0 \pm 0.8$	
		2.52	$4.0 \pm 0.5$	
		3.06	$57 \pm 3$	

Table 18.25: Radiative decays in  $^{18}\text{F}$  <sup>a</sup> (continued)

$E_i$ (MeV)	$J_i^\pi$	$E_f$ (MeV)	Branch (%)	Widths and mixing ratios
6.39	$2^+; 0+1$	3.72	$1.4 \pm 0.7$	$\delta = -(0.01 \pm 0.14)$ $\Gamma_\gamma = 0.44 \pm 0.18 \text{ eV}^c$ $\delta = -(0.25 \pm 0.10)$
		3.84	$4.6 \pm 1.0$	
		4.12	$2.4 \pm 1.7$	
		4.96	$13.0 \pm 1.5$	
		0	$1.5 \pm 0.5$	
		0.94	$75 \pm 3$	
		1.70	$6.8 \pm 1.7$	
		3.84	$14.1 \pm 1.6$	
6.48	$3^+; 0$	4.12	$2.3 \pm 0.5$	$\delta = 0.1 \pm 0.2$  $\Gamma_\gamma = 74 \pm 21 \text{ meV}^c$
		0	$13 \pm 2$	
		0.94	$33 \pm 2$	
		1.12	$10 \pm 2$	
		1.70	$4 \pm 2$	
		2.52	$4 \pm 2$	
		3.06	$21 \pm 3$	
		3.79	$4 \pm 2$	
		3.84	$9 \pm 2$	
		4.96	$2 \pm 2$	
6.57	$5^+; 0$	0.94	$15.2 \pm 1.6$	$\Gamma_\gamma = 2.6 \pm 0.5 \times 10^{-2} \text{ eV}^{c,d}$
		3.36	$83 \pm 3$	
		5.30	$2.3 \pm 0.6$	
		0.94	$8.9 \pm 0.6$	
6.64	$2^-; 1$	2.10	$58 \pm 3$	$\Gamma_\gamma = 1.4 \pm 0.4 \text{ eV}^c$
		3.13	$22.0 \pm 1.3$	
		3.72	$0.9 \pm 0.2$	
		3.79	$2.4 \pm 0.2$	
		4.12	$1.0 \pm 0.3$	
		4.86	$2.6 \pm 0.2$	
		5.50	$4.0 \pm 0.3$	
		0.94	$12.6 \pm 0.9$	
6.78	$4^+; 0$	0.94	$12.6 \pm 0.9$	$\Gamma_\gamma = 0.31 \pm 0.08 \text{ eV}^c$ $\delta = -(0.35 \pm 0.18)$

Table 18.25: Radiative decays in  $^{18}\text{F}$  <sup>a</sup> (continued)

$E_i$ (MeV)	$J_i^\pi$	$E_f$ (MeV)	Branch (%)	Widths and mixing ratios
6.80	$1^+, 2^+, 3^+; (0)$	1.12	$25.2 \pm 1.3$	$\delta = -(1.4 \pm 1.1)$ $\delta = 0.13 \pm 0.13$
		4.65	$62 \pm 2$	
		0	$20 \pm 2$	
		0.94	$20 \pm 2$	
		3.06	$50 \pm 3$	
		3.84	$3.0 \pm 1.6$	
		4.96	$7.0 \pm 1.7$	
6.88	$3, 4^-; 0$	2.10	$9 \pm 2$	
		4.65	$91 \pm 2$	
7.34	$1^-; 1$	0	$4 \pm 0.5$	
		1.08	$54 \pm 2$	
		2.10	$18 \pm 1$	
		3.06	$1 \pm 0.5$	
		3.13	$8 \pm 0.5$	
		4.23	$15 \pm 0.6$	
7.48	(2)	0.94	100	
7.52		0.94	$5 \pm 4$	
		2.10	$7 \pm 5$	
		3.79	$33 \pm 5$	
		4.40	$55 \pm 7$	
7.53	$2^-$	0	$10 \pm 3$	
		0.94	$14 \pm 6$	
		2.10	$50 \pm 9$	
		3.79	$26 \pm 7$	
7.59		0	$18 \pm 7$	
		0.94	$14 \pm 12$	
		1.12	$9 \pm 7$	
		4.65	$59 \pm 16$	

<sup>a</sup> For earlier references see Tables 18.11 in (1978AJ03) and 18.12 in (1983AJ01). See these tables also for upper limits for transitions to other states.

<sup>b</sup> (1982FR15): see reactions 6 and 23.

<sup>c</sup>  $\Gamma_\gamma$  = total radiative width for this state.

<sup>d</sup>  $\Gamma_\alpha = \Gamma \approx 560$  eV,  $\Gamma_p < 4.5$  eV.

<sup>d</sup> See Table 18.27.

Observed resonances are displayed in Table 18.27. See also <sup>17</sup>O in (1986AJ04, 1993TI07).

8. (a)  $^{14}\text{N}(\alpha, \alpha')^{14}\text{N}$   $E_b = 4.415$   
 (b)  $^{14}\text{N}(\alpha, 2\alpha)^{10}\text{B}$   $Q_m = -11.613$   
 (c)  $^{14}\text{N}(\alpha, ^6\text{Li})^{12}\text{C}$   $Q_m = -8.798$

Table 18.26: Lifetime measurements of some <sup>18</sup>F states

<sup>18</sup> F* (MeV)	$J^\pi; T$	$\tau_m$	References
0.94	$3^+; 0$	$67.6 \pm 2.5$ ps	mean <sup>a</sup>
1.04	$0^+; 1$	$2.7 \pm 0.4$ fs	<sup>b</sup>
		$2.2 \pm 0.6$ fs	(1983CA21)
		$2.55 \pm 0.45$ fs	(1983CA21) <sup>c</sup>
1.08	$0^-; 0$	$27.5 \pm 1.9$ ps	mean <sup>a</sup>
1.12	$5^+; 0$	$234 \pm 10$ ns	mean <sup>b</sup>
1.70	$1^+; 0$	$0.971 \pm 0.30$ ps	(1982BA40)
		$0.897 \pm 0.057$ ps	(1983MO16) <sup>d</sup>
		$0.955 \pm 0.027$ ps	mean
2.10	$2^-; 0$	$5.12 \pm 0.56$ ps	(1982BA40)
		$4.93 \pm 0.78$ ps	(1983MO16)
		$5.06 \pm 0.46$ ps	mean
2.52	$2^+; 0$	$0.605 \pm 0.029$ ps	(1982BA40)
		$0.554 \pm 0.045$ ps	(1983MO16)
		$0.590 \pm 0.024$ ps	mean
3.06	$2^+; 1$	$< 1.2$ fs	(1982BA40) <sup>a,e</sup>
3.13	$1^-; 0$	$0.403 \pm 0.018$ ps	(1982BA40)
		$0.343 \pm 0.022$ ps	(1983MO16)

Table 18.26: Lifetime measurements of some  $^{18}\text{F}$  states (continued)

$^{18}\text{F}^*$ (MeV)	$J^\pi; T$	$\tau_m$	References
3.36	$3^+; 0$	$0.39 \pm 0.02$ ps <sup>A</sup>	
		$0.435 \pm 0.041$ ps	(1982BA40)
		$0.451 \pm 0.034$ ps	(1983MO16)
		$0.44 \pm 0.03$ ps <sup>A</sup>	
3.72	$1^+; 0$	$4 \pm 2$ fs	(1973RO04)
		$2.7^{+4.1}_{-2.7}$ fs <sup>A</sup>	(1982BA40) <sup>c</sup>
3.79	$3^-; 0$	$1.91 \pm 0.17$ ps	(1982BA40)
		$1.90 \pm 0.20$ ps	(1983MO16)
		$1.91 \pm 0.13$ ps	mean
3.84	$2^+; 0$	$17.4 \pm 3.6$ fs	(1982BA40)
		$21 \pm 4$ fs	(1983MO16)
		$19.0 \pm 2.7$ fs	mean
4.12	$3^+; 0$	$91 \pm 22$ fs	(1973RO06)
4.23	$2^-; 0$	$110 \pm 15$ fs	(1973RO06)
4.36	$1^+; 0$	$27 \pm 10$ fs	(1973RO06)
4.40	$4^-; 0$	$58 \pm 12$ fs	(1973RO06)
4.65	$4^+; 1$	$< 10$ fs	(1973RO06)
4.85	$5^-; 0$	$5.2 \pm 0.9$ ps	(1973RO06)
4.86	$1^-; 0$	$66 \pm 18$ fs	(1973RO06)
4.96	$2^+; 1$	$< 4$ fs	(1973RO06)
5.30	$4^+; 0$	$30 \pm 5$ fs	(1973RO06)
5.50	$3^{(-)}; 0$	$63 \pm 25$ fs	(1973RO06)
5.79	$2^-; 0$	$15 \pm 10$ fs	(1973RO06)

A = adopted.

<sup>a</sup> See Table 18.12 in (1978AJ03).

<sup>b</sup> See Table 18.13 in (1983AJ01).

<sup>c</sup> See also (1985KE1C).

<sup>d</sup> See also (1982MO09).

<sup>e</sup> See also (1983MO16).



Table 18.27: Resonances in  $^{14}\text{N} + \alpha$  below  $E_\alpha = 5 \text{ MeV}$  <sup>a</sup>

$E_\alpha$ (MeV $\pm$ keV)	Particles out	$\Gamma_{\text{c.m.}}$ (keV)	$(2J + 1)\Gamma_\gamma\Gamma_\alpha/\Gamma$ (eV)	$J^\pi; T$	$E_x$ (MeV)
			$< 2 \times 10^{-5}$		4.657
0.559	$\gamma$		$(2.8 \pm 0.5) \times 10^{-4}$	1; 0	4.850
0.698			$< 0.5 \times 10^{-4}$	2 <sup>+</sup> ; 1	4.958
1.136 $\pm$ 3	$\gamma$		0.084 $\pm$ 0.004	4 <sup>+</sup> ; 0	5.299
1.398 $\pm$ 3	$\gamma$		0.022 $\pm$ 0.003	3 <sup>(-)</sup> ; 0	5.502
1.527	$\gamma, \alpha_0$		1.44 $\pm$ 0.14	1 <sup>+</sup>	5.603 <sup>e</sup>
1.529 $\pm$ 2	$\gamma, \alpha_0$	< 1.2	2.60 $\pm$ 0.21	1 <sup>-</sup> ; 0 + 1	5.604 <sup>f</sup>
1.618 $\pm$ 2	$\gamma, \alpha_0$	< 0.8	1.4 $\pm$ 0.2 <sup>b</sup>	1 <sup>-</sup> ; 0 + 1	5.673 <sup>g</sup>
1.765 $\pm$ 4	$\gamma$		0.047 $\pm$ 0.018	2 <sup>-</sup> ; 0	5.788
2.160 $\pm$ 4	$\gamma$		0.20 $\pm$ 0.04	4 <sup>-</sup> ; 0	6.095
2.166 $\pm$ 7	$\gamma, \alpha_0$		0.08 $\pm$ 0.03	1, 2, 3 <sup>(-)</sup> ; 0	6.100
			<sup>c</sup>		
2.348 $\pm$ 3	$\gamma, \alpha_0$	< 0.8		3 <sup>-</sup> ; 0 + 1	6.241 <sup>h</sup>
2.372 $\pm$ 3	$\gamma, \alpha_0$	< 3		1 <sup>+</sup> ; (0)	6.260 <sup>i</sup>
			<sup>d</sup>		
2.438 $\pm$ 4	$\gamma$		0.52 $\pm$ 0.12	3 <sup>+</sup> ; 0	6.311
2.532 $\pm$ 4	$\gamma$		1.6 $\pm$ 0.4	2 <sup>+</sup> ; 0 + 1	6.384
			0.16 $\pm$ 0.06	3 <sup>+</sup> ; (0)	6.480
2.767 $\pm$ 4	$\gamma, \alpha_0$	(< 0.8)	0.29 $\pm$ 0.06	5 <sup>+</sup> ; 0	6.567
2.870 $\pm$ 4	$\gamma, p_0$	< 1.6	2.7 $\pm$ 0.5	2 <sup>-</sup> ; 1	6.647
2.870 $\pm$ 6	$\alpha_0$	93 $\pm$ 5	$\Gamma_\alpha/\Gamma = 0.85$	1 <sup>-</sup>	6.647
			0.12 $\pm$ 0.07	4 <sup>+</sup> ; 0	6.78
			< 0.2	1 <sup>+</sup> , 2 <sup>+</sup> , 3 <sup>+</sup> ; (0)	6.803
3.080 $\pm$ 6	$p_0, \alpha_0$	101 $\pm$ 5		2 <sup>-</sup>	6.810
3.576 $\pm$ 4	$\alpha_0$	< 4		(4 <sup>+</sup> )	7.196
3.67	$\alpha_0$	45 $\pm$ 10		(1 <sup>+</sup> )	7.27
3.72	$p_0, \alpha_0$	53 $\pm$ 6		(3 <sup>-</sup> )	7.31
4.00	$p_0, \alpha_0$	35		(3 <sup>-</sup> )	7.53
4.05	$p_0, \alpha_0$	60			7.57
4.11	$p_0, \alpha_0$	40			7.61

Table 18.27: Resonances in  $^{14}\text{N} + \alpha$  below  $E_\alpha = 5 \text{ MeV}$  <sup>a</sup> (continued)

$E_\alpha$ (MeV $\pm$ keV)	Particles out	$\Gamma_{\text{c.m.}}$ (keV)	$(2J + 1)\Gamma_\gamma\Gamma_\alpha/\Gamma$ (eV)	$J^\pi; T$	$E_x$ (MeV)
4.28	$p_0, \alpha_0$	120			7.74
4.50	$p_0, \alpha_0$	30		$(2^-)$	7.92
4.55	$p_0, \alpha_0$	70		$(1^+)$	7.95

<sup>a</sup> References are displayed in Tables 18.13 of (1972AJ02, 1978AJ03). Higher resonances observed in  $^{14}\text{N}(\alpha, \alpha_1)$  are listed in Table 18.14 of (1978AJ03).

<sup>b</sup>  $\omega_\gamma = 0.45 \pm 0.02$  (1982BE29).

<sup>c</sup>  $\leq 0.07$  for  $^{18}\text{F}^*(6.11, 6.16 \text{ MeV})$  (1973RO03).

<sup>d</sup>  $\leq 0.03$  for  $^{18}\text{F}^*(6.28 \text{ MeV})$  (1973RO03).

<sup>e</sup>  $\Gamma_\alpha = 42.8 \pm 1.6 \text{ eV}$ ,  $\Gamma_\gamma = 0.485 \pm 0.046 \text{ eV}$ ,  $l_\alpha = 0$  (1980MA26). See also Table 18.30.

<sup>f</sup>  $\Gamma_\alpha = 32.0 \pm 2.1 \text{ eV}$ ,  $\Gamma_\gamma = 0.891 \pm 0.074 \text{ eV}$ ,  $l_\alpha = 1$ .  $\Delta E_x$  for  $^{18}\text{F}^*(5.603, 5.605 \text{ MeV})$  is  $1.84 \pm 0.04 \text{ keV}$  (1980MA26). See also Table 18.30.

<sup>g</sup>  $\Gamma_\alpha = 130 \pm 5 \text{ eV}$ ,  $\Gamma_\gamma = 1.4 \pm 0.3 \text{ eV}$ ,  $l_\alpha = 1$  (1980MA26). More recently, an accurate energy measurement for this level by (1989BO01) gave  $E_x = 5672.57 \pm 0.32 \text{ keV}$ .

<sup>h</sup> This resonance corresponds to two states at  $E_x = 6240$  and  $6242 \text{ keV}$ . The lower member of the doublet (both of which have  $J^\pi = 3^-$  and mixed isospin) has  $\Gamma_\alpha = 133 \pm 4 \text{ eV}$ ,  $\Gamma_\gamma = 0.80 \pm 0.11 \text{ eV}$ ; the higher has  $\Gamma_\alpha = 137 \pm 0.4 \text{ eV}$ ,  $\Gamma_\gamma = 0.73 \pm 0.11 \text{ eV}$  (1979KI12).

<sup>i</sup>  $\Gamma_\alpha = 580 \pm 12 \text{ eV}$ ,  $\Gamma_p = 25_{-25}^{+35} \text{ eV}$  (1979KI12).

Observed anomalies in the elastic scattering [reaction (a)] are exhibited in Table 18.27. Resonances in the  $\alpha_1$  isospin-forbidden yield are displayed in Table 18.14 of (1978AJ03). In the  $\alpha_1$  study, carried out for  $E_\alpha = 7.6\text{--}16.9 \text{ MeV}$ , a partial-wave analysis involving a method of removing ambiguities and parametrizing  $S$ -matrix elements gives the level parameters of 151 isospin mixed, natural-parity states in  $^{18}\text{F}$  with  $10.4 < E_x < 17.5 \text{ MeV}$ . Many of these states have also been reported in the  $^{16}\text{O}(d, \alpha_1)$  reaction [Table 18.16 of (1978AJ03)]. The agreement is best for low-lying  $2^+$  or  $4^+$  states, and is quite good for  $3^-$  and  $5^-$  states, while for high- $J$  states the greater centrifugal barrier for  $^{16}\text{O} + d$  at the same  $E_x$  leads to a relative suppression of high- $J$  states in the  $^{16}\text{O} + d$  work. A study of the energy dependence of averaged intensities of the partial waves shows some indication that the lower partial waves conserve isospin as  $E_x$  increases.

The total cross sections for formation of  $^{10}\text{B}$  and  $^6\text{Li}$  have been studied for  $E_\alpha = 21$  to  $42 \text{ MeV}$  [see (1978AJ03)], as has the cross section for production of 1.64 and 2.31 MeV  $\gamma$ -rays from threshold to  $E_\alpha = 26 \text{ MeV}$  (1985DY05). See also (1987AJ02), and see (1987BU27, 1989BE1R, 1990WE14, 1991LE33).

$$9. \text{ (a) } ^{14}\text{N}(^6\text{Li}, d)^{18}\text{F} \quad Q_m = 2.940$$

$$\text{ (b) } ^{14}\text{N}(^6\text{Li}, d\alpha)^{14}\text{N} \quad Q_m = -1.475$$

Angular distributions have been measured for the deuteron groups to  $^{18}\text{F}^*(5.34 [4^+], 6.56 [5^+], 9.58, 11.2, 14.1)$  at  $E(^6\text{Li}) = 36$  MeV. Angular correlations lead to  $J^\pi = 6^+$  and  $8^+$  for  $^{18}\text{F}^*(9.58, 14.1)$  and the data are consistent with  $J^\pi = 7^+$  for  $^{18}\text{F}^*(11.2)$  (1983ET02). For the earlier work see (1978AJ03).

$$10. \ ^{14}\text{N}(^7\text{Li}, \text{t})^{18}\text{F} \quad Q_{\text{m}} = 1.948$$

At  $E(^7\text{Li}) = 36$  MeV the  $K^\pi = 1^+$  band appears to be selectively populated. States at  $E_{\text{x}} = 9.58 \pm 0.02, 11.22 \pm 0.03$  and  $14.18 \pm 0.04$  MeV are strongly populated. It is suggested that the first two are the  $6^+$  and  $7^+$  members of that band: see reaction 8. [Angular distributions are reported for  $^{18}\text{F}^*(1.70, 2.10, 2.52, 3.36, 4.40, 5.30, 6.57, 9.58, 11.22, 14.18)$ .] See (1978AJ03, 1987AJ02) for the earlier work.

$$11. \text{ (a) } ^{14}\text{N}(^{11}\text{B}, ^7\text{Li})^{18}\text{F} \quad Q_{\text{m}} = -4.250$$

$$\text{ (b) } ^{14}\text{N}(^{13}\text{C}, ^9\text{Be})^{18}\text{F} \quad Q_{\text{m}} = -6.233$$

These reactions have been studied at  $E(^{11}\text{B}) = 115$  MeV and  $E(^{13}\text{C}) = 105$  MeV. Differential cross sections at three angles are reported for the transitions to  $^{18}\text{F}^*(9.58, 10.57 \pm 0.07, 11.2)$  in reaction (a) and to  $^{18}\text{F}^*(5.30, 6.57, 9.58, 10.60 \pm 0.08, 11.2)$  in reaction (b). In addition to these states  $^{18}\text{F}^*(14.18)$  is strongly excited in both reactions, and transitions to  $^{18}\text{F}^*(15.79 \pm 0.10, 18.62 \pm 0.12)$  are also reported: see (1983AJ01).

$$12. \text{ (a) } ^{15}\text{N}(^3\text{He}, \gamma)^{18}\text{F} \quad Q_{\text{m}} = 14.156$$

$$\text{ (b) } ^{15}\text{N}(^3\text{He}, \alpha)^{14}\text{N} \quad Q_{\text{m}} = 9.745 \quad E_{\text{b}} = 14.160$$

Excitation functions have been measured for  $E(^3\text{He}) = 2.5$  to  $16$  MeV for the  $\gamma_0$  and  $\gamma_{1 \rightarrow 4}$  yields. Resonances are observed corresponding to  $E_{\text{x}} = (19.00 \pm 0.15) [\gamma_{1 \rightarrow 4}]$ ,  $(20.1 \pm 0.2) [\gamma_0, \gamma_{1 \rightarrow 4}]$ ,  $(22.7 \pm 0.2) [\gamma_0, \gamma_{1 \rightarrow 4}]$  and  $(24.1 \pm 0.2)$  MeV  $[\gamma_{1 \rightarrow 4}]$ , with  $\Gamma_{\text{c.m.}} = (0.5 \pm 0.15)$ ,  $(1.6 \pm 0.1)$ ,  $(1.2 \pm 0.1)$  and  $(1.4 \pm 0.3)$  MeV, respectively. The  $\gamma_0$  yield is dominated by  $^{18}\text{F}^*(20.10)$  [(1983WA05): see for  $(2J+1)\Gamma_{^3\text{He}}\Gamma_{\gamma}$  values]. It is suggested that structures decaying by  $\gamma_0$  have  $J^\pi = 2^-$  (and possibly  $T = 1$ ) (1983WA05). For analyzing power measurements at  $E(^3\text{He}) = 33$  MeV see (1986DR03).

$$13. \ ^{15}\text{N}(^6\text{Li}, \text{t})^{18}\text{F} \quad Q_{\text{m}} = -1.635$$

At  $E(^6\text{Li}) = 30$  MeV preferential excitation of odd-parity states of  $^{18}\text{F}$  below  $E_x = 5$  MeV is reported. Angular distributions of the tritons to  $^{18}\text{F}^*(0, 0.94, 2.10, 4.40)$  [ $J^\pi = 1^+, 3^+, 2^-, 4^-$ ] are all strongly forward peaked: see (1978AJ03).

14. (a)  $^{15}\text{N}(^{11}\text{B}, ^8\text{Li})^{18}\text{F}$   $Q_m = -13.048$   
 (b)  $^{15}\text{N}(^{12}\text{C}, ^9\text{Be})^{18}\text{F}$   $Q_m = -12.119$

These reactions have been studied with  $E(^{11}\text{B}) = E(^{12}\text{C}) = 115$  MeV. Reaction (a) is dominated by the transitions to  $^{18}\text{F}^*(1.12)$  [presumably  $J^\pi = 5^+$  state, although the group is unresolved] and to  $^{18}\text{F}^*(7.15, 9.45)$  [ $J^\pi = (7^-)$  and  $(6^-)$ ]. No single state is strongly preferentially populated in reaction (b). Differential cross sections for  $^{18}\text{F}^*(4.40, 6.10, 7.15, 9.45)$  [ $J^\pi = 4^-, (5^-), (7^-), (6^-)$ ], are fitted by FRDWBA: see (1983AJ01).

15.  $^{16}\text{O}(d, \gamma)^{18}\text{F}$   $Q_m = 7.526$

The capture cross section rises from  $0.1 \mu\text{b}$  at  $E_d = 0.4$  MeV to  $25 \mu\text{b}$  at  $3.5$  MeV:  $\Gamma_\gamma$  over this range is  $\approx 2$  eV: see (1972AJ02).

16. (a)  $^{16}\text{O}(d, n)^{17}\text{F}$   $Q_m = -1.624$   $E_b = 7.526$   
 (b)  $^{16}\text{O}(d, p)^{17}\text{O}$   $Q_m = 1.919$

Excitation functions and polarization studies have been carried out to  $E_d = 17$  MeV [see (1978AJ03, 1983AJ01)] and at  $E_d \approx 5.6$  to  $8.3$  MeV (1985GR1B;  $p_0, p_3, p_4$ ). Structures attributed to states in  $^{18}\text{F}$  are displayed in Table 18.28. See also  $^{17}\text{O}$  and  $^{17}\text{F}$  in (1986AJ04, 1993TI07), (1987AJ02), and see (1992LA08) for applications.

17.  $^{16}\text{O}(d, d')^{16}\text{O}$   $E_b = 7.526$

The yields and polarized observables of elastically scattered deuterons have been reported for  $E_d = 0.65$  to  $56$  MeV: see (1978AJ03, 1983AJ01). More recent measurements are those by (1985GR1B) [excitation functions for  $E_d \approx 5.6$  to  $8.3$  MeV] and the polarization studies at  $E_d = 20.5$  MeV (1984FR14; TAP),  $56$  MeV (1986MA32, VAP, TAP) and  $200, 400$  and  $700$  MeV (1987NG01; VAP, TAP). An analysis for  $E_d = 400$  MeV in terms of the folding model is discussed in (1987GR16). Virtual breakup effects in  $(d, d)$  elastic scattering have been studied (1988IS02). For references to earlier work see (1987AJ02), and see the  $^{16}\text{O}$  sections of (1986AJ04, 1993TI07).

18.  $^{16}\text{O}(\text{d}, \alpha)^{14}\text{N}$  $Q_m = 3.111$  $E_b = 7.526$ 

The yields of various groups of  $\alpha$ -particles have been measured for  $E_d \leq 20$  MeV: see (1978AJ03, 1983AJ01). The yield curves have been fitted in terms of a large number of states in  $^{18}\text{F}$ : see Table 18.28 here, and 18.16 in (1978AJ03).

Table 18.28: Maxima in the yields of  $^{16}\text{O} + \text{d}$  <sup>a</sup>

$E_d$ (MeV $\pm$ keV)	Particles out	$\Gamma_{\text{c.m.}}$ (keV)	$J^\pi; T$	$E_x$ (MeV)
0.895	$p_1, \alpha_0$	$210 \pm 25$		(8.320)
1.048	$p_1, d_0, \alpha_0$	$88 \pm 10$	$1^+$	8.456
1.199	$\alpha_0$	$230 \pm 30$		(8.590)
1.298	$p_1, d_0, \alpha_0$	$13 \pm 3$		(8.678)
1.325	$d_0, \alpha_0$			(8.702)
1.482	$\alpha_0$	$40 \pm 5$		(8.842)
1.563	$d_0, \alpha_0$	$121 \pm 15$		(8.914)
1.616	$\alpha_0$	$19 \pm 15$		(8.961)
1.765	$d_0, \alpha_0$	$141 \pm 10$		(9.093)
1.885	$p_0, p_1, d_0, \alpha_0$	$108 \pm 12$	$3, 4^-; 0$	9.200
2.22	$n_0, \alpha_0$		$2, 3^+; 0$	9.50
2.28	$\alpha_0$		$2, 3^+; 0$	(9.55)
2.34	$n_0, p_1$			(9.60)
2.55	$p_1$			(9.79)
2.92	$n_0, p_0, p_1$			10.12
3.05	$\alpha_0$		$3, 4^-; 0$	10.24
3.13	$n, p_1, \alpha_0, \alpha_1$		$\geq 2; 0$	10.31
3.37	$n_0, p_0, p_1, \alpha_1$			10.52
3.47	$\alpha_0$		$4, 5^+; 0$	10.61
3.68	$n_0, p_0, p_1, \alpha_1$		$2^+$	10.79
3.80	$p_0, \alpha_0$		$\geq 2^+; 0$	10.90
3.94	$n, p_1, \alpha_1$			11.03
3.95	$p_1, \alpha_0$	$\simeq 35$	$3, 4^-; 0$	11.03
4.07	$n, p_1$			11.14
4.38	$p_1, \alpha_0$		$4, 5^+; 0$	11.42

Table 18.28: Maxima in the yields of  $^{16}\text{O} + \text{d}$  <sup>a</sup> (continued)

$E_d$ (MeV $\pm$ keV)	Particles out	$\Gamma_{\text{c.m.}}$ (keV)	$J^\pi; T$	$E_x$ (MeV)
4.57	$\alpha_0$		5, 6 <sup>-</sup> ; 0	11.58
4.80	$d_0, \alpha_0$		$\geq 3; 0$	11.79
4.93	$\alpha_0$		5, 6 <sup>-</sup> ; 0	11.90
5.05 $\pm$ 15	$\alpha_4$	40		12.01
5.11	$\alpha_0, \alpha_2, \alpha_4$	60	4, 5 <sup>+</sup> ; 0	12.06
5.17	$\alpha_0$	55	$T = 0$	12.12
5.32	$\alpha_0$	70		12.25
5.34	$\alpha_0, \alpha_2$	170		12.27
5.40	$\alpha_0, \alpha_4$	130		12.32
5.47	$\alpha_4$	80		12.38
5.49	$\alpha_2, \alpha_3, \alpha_4$	120		12.40
5.59	$\alpha_0, \alpha_2$	120		12.49
5.65	$\alpha_0, \alpha_2$	140		12.54
5.77	$\alpha_0$	180	2 <sup>+</sup>	12.65
5.80	$\alpha_0, \alpha_2, \alpha_4$	160		12.68
5.81	$\alpha_3, \alpha_4$	80	5 <sup>-</sup>	12.69
5.91	$\alpha_2$	160		12.77
6.00	$\alpha_0$	120		12.85
6.11	$\alpha_0, \alpha_4$	120		12.95
6.19	$\alpha_2, \alpha_3$	200	$\geq 4; 0$	13.02
6.25	$\alpha_0, \alpha_4$	150	$T = 0$	13.08
6.30	$\alpha_0, \alpha_2$	160		13.12
6.34	$\alpha_0, \alpha_3$	160	5, 6 <sup>-</sup> ; 0	13.16
6.38	$\alpha_0, \alpha_3$	145	$T = 0$	13.19
6.43	$\alpha_0, \alpha_2$	120		13.24
6.46	$\alpha_0, \alpha_4$	100		13.26
6.54	$\alpha_0, \alpha_2$	135		13.33
6.61	$\alpha_2, \alpha_3, \alpha_4$	120		13.40
6.64	$\alpha_0, \alpha_2$	200		13.42
6.66	$\alpha_0$	100		13.44

Table 18.28: Maxima in the yields of  $^{16}\text{O} + \text{d}$  <sup>a</sup> (continued)

$E_d$ (MeV $\pm$ keV)	Particles out	$\Gamma_{\text{c.m.}}$ (keV)	$J^\pi; T$	$E_x$ (MeV)
6.72	$\alpha_2$	100		13.49
6.73	$\alpha_2$	100		13.50
6.80	$\alpha_2, \alpha_3$	140		13.56
6.84	$\alpha_0, \alpha_2, \alpha_4$	150		13.60
6.94	$\alpha_0, \alpha_3$	90		13.69
7.10	$\alpha_3, \alpha_4$	60	$4^-, 5^+$	13.83
7.27	$\alpha_3$	150		13.98
7.31	$\alpha_2$	60	$4^-, 5^+$	14.02
7.34	$\alpha_0, \alpha_3, \alpha_4$	200		14.04
7.38	$\alpha_0, \alpha_3$	210		14.08
7.41	$\alpha_3$	60	$4^-, 5^+$	14.10
7.49	$\alpha_0$	220		14.18
7.58	$\alpha_0$	200	$\geq 4; 0$	14.26
7.62	$\alpha_4$	85		14.29
7.66	$\alpha_0, \alpha_2, \alpha_4$	130	$T = 0$	14.33
7.67	$\alpha_0, \alpha_2, \alpha_3, \alpha_4$	250	$T = 0$	14.34
7.74	$\alpha_3$	200	$3^+, 4^-$	14.40
7.80	$\alpha_0, \alpha_4$	70		14.45
7.82	$\alpha_0, \alpha_2$	225		14.47
7.99	$\alpha_4$	200		14.62
8.02	$\alpha_0$	150		14.65
8.03	$\alpha_3$	310		14.66
8.07	$\alpha_0$	120		14.69
8.08	$\alpha_3, \alpha_4$	310		14.70
8.21	$\alpha_2$	250		14.82
8.25	$\alpha_4$	380		14.85
8.30	$\alpha_0, \alpha_2, \alpha_3$	210		14.90
8.34	$\alpha_4$	115		14.93
8.37	$\alpha_0$	130		14.96
8.37	$\alpha_0, \alpha_3$	250		14.96

Table 18.28: Maxima in the yields of  $^{16}\text{O} + \text{d}$  <sup>a</sup> (continued)

$E_d$ (MeV $\pm$ keV)	Particles out	$\Gamma_{\text{c.m.}}$ (keV)	$J^\pi; T$	$E_x$ (MeV)
8.40	$\alpha_0$	310		14.99
8.43	$\alpha_4$	120		15.01
8.52	$\alpha_3, \alpha_4$	160	$4^-, 5^+$	15.09
8.52	$\alpha_2$	150		15.09
8.56	$\alpha_2$	220		15.13
8.58	$\alpha_4$	180		15.15
8.61	$\alpha_0, \alpha_3$	200		15.17
8.65	$\alpha_0, \alpha_2$	135		15.21
8.72	$\alpha_2, \alpha_4$	120		15.27
8.76	$\alpha_2$	160		15.30
8.79	$\alpha_0$	200		15.33
8.80	$\alpha_0, \alpha_3, \alpha_4$	200	$5^+, 6^-$	15.34
8.89	$\alpha_3$	110		15.42
8.93	$\alpha_3, \alpha_4$	190		15.46
8.97	$\alpha_2, \alpha_4$	210		15.49
9.00	$\alpha_0, \alpha_2$	190		15.52
9.62	$\alpha_3$	220	$4^-, 5^+$	16.07
10.35	$\alpha_3$	60	$4^-, 5^+$	16.72
11.15	$\alpha_3$	70	$4^-, 5^+, 6^-$	17.43

<sup>a</sup> For references see Table 18.15 in (1978AJ03). This table does not include the structures in  $\alpha_1$  leading to isospin-mixed states in  $^{18}\text{F}$ : for the latter see Table 18.16 in (1978AJ03).

A detailed study by (1973JO13) of the isospin-forbidden  $\alpha_1$  yield, analyzed by  $S$ -matrix theory, identifies a large number of isospin-mixed states in  $^{18}\text{F}$ , possibly as many as 138 with  $9.2 < E_x < 19.4$  MeV. The reaction mechanism appears to be almost entirely compound nuclear. The isospin impurity, averaged over 1 MeV intervals, is 3–10% for the above  $E_x$  range. The average coherence width increases from  $\approx 100$  keV at  $E_x = 14$  MeV to  $\approx 500$  keV at  $E_x = 20$  MeV. The level densities appear to be consistent with predictions of the Fermi-gas model (1973JO13). See also (1985JOZZ). [For mixed isospin states observed in  $^{14}\text{N}(\alpha, \alpha_1)$  see Table 18.14 in (1978AJ03).] Polarized beam measurements are reported for  $E_d = 6.8$  to 16 MeV: see (1978AJ03, 1983AJ01).



19.  $^{16}\text{O}(\text{d}, ^6\text{Li})^{12}\text{C}$ 

$$Q_{\text{m}} = -5.687$$

$$E_{\text{b}} = 7.526$$

Vector and tensor polarized beam measurements are reported for the transitions to  $^{12}\text{C}^*(0, 4.4)$  at  $E_{\text{d}} = 18$  and 22 MeV ([1987TA07](#); VAP, TAP) and 51.7 MeV ([1986YA12](#); VAP; also to  $^{12}\text{C}^*(14.1)$ ).

20.  $^{16}\text{O}(\text{t}, \text{n})^{18}\text{F}$ 

$$Q_{\text{m}} = 1.269$$

Recent measurement of neutron yields for  $E_{\text{x}} = 20$  MeV are discussed in ([1993DR03](#), [1993DR04](#)). Applications are discussed in ([1987BO16](#), [1990BA1S](#)). For earlier work see ([1983AJ01](#), [1987AJ02](#)).

21.  $^{16}\text{O}(^3\text{He}, \text{p})^{18}\text{F}$ 

$$Q_{\text{m}} = 2.032$$

Excitation energies derived from measurements of  $\gamma$ -rays are displayed in Table [18.29](#) together with  $l$ -assignments obtained from distorted-wave analyses, and  $J^{\pi}$ ,  $T$  and  $K^{\pi}$  assignments from branching ratios, radiative widths, linear polarization,  $\gamma$ -ray angular distributions and  $\tau_{\text{m}}$  measurements [see also Tables [18.25](#) and [18.26](#)]. Studies of this reaction, together with the work on  $^{14}\text{N}(\alpha, \gamma)$  and  $^{17}\text{O}(\text{p}, \gamma)$ , have defined the low-lying states of  $^{18}\text{F}$ .

The  $g$ -factor of  $^{18}\text{F}^*(0.94)$  [ $J^{\pi} = 3^+$ ] is  $(+0.56 \pm 0.05)$ : see ([1983AJ01](#)). The circular polarization of the 1.08 MeV  $\rightarrow$  g.s.  $\gamma$ -ray,  $P_{\gamma} = (-10 \pm 18) \times 10^{-4}$  ([1982AH07](#)),  $(2.7 \pm 5.7) \times 10^{-4}$  ([1985BI03](#), [1988BI07](#)),  $(1.6 \pm 5.6) \times 10^{-4}$  ([1985EV03](#)),  $(1.7 \pm 5.8) \times 10^{-4}$  ([1987PA07](#)). The weak pion-nucleon coupling constant deduced from the weighted average of all recent  $P_{\gamma}$  measurements [ $(1.2 \pm 3.9) \times 10^{-4}$ ] is  $(0.3_{-0.3}^{+1.0}) \times 10^{-7}$ . Together with PNC matrix elements in other experiments this suggests that the isovector weak NN interaction may be strongly suppressed compared with the isoscalar weak NN interaction ([1985EV03](#), [1987PA07](#)). For a measurement of the ICC of the 0.94, 1.02, 1.04, and 1.08 MeV  $\gamma$ -rays see ([1986KR04](#)). See also ([1978AJ03](#), [1983AJ01](#), [1987AJ02](#)) and  $^{19}\text{Ne}$ .

A discussion of nuclear tests of fundamental interactions is presented in ([1989MC1C](#)). For recent work on the use of this reaction for oxygen analysis, see ([1991BA62](#), [1992CO08](#)). For applications related to  $^{18}\text{F}$  production see ([1991GU05](#), [1991SU17](#)).

22.  $^{16}\text{O}(\alpha, \text{d})^{18}\text{F}$ 

$$Q_{\text{m}} = -16.321$$

Angular distributions of the deuteron groups to  $^{18}\text{F}^*(1.12)$  [ $J^{\pi} = 5^+$ ] have been studied at  $E_{\alpha} = 28.0$  to 33.6 MeV: see ([1983AJ01](#)). At  $E_{\alpha} = 65.3$  MeV a number of angular distributions are reported to  $^{18}\text{F}$  states with  $E_{\text{x}} \leq 11.4$  MeV:  $^{18}\text{F}^*(9.49, 10.54)$  are suggested to have  $J^{\pi} = 6^-$  and  $7^+$  respectively ([1986KA36](#)). See, however, reactions 9 and 10. The use of this reaction in  $^{18}\text{F}$  production is discussed in ([1991GU05](#)).

23.  $^{16}\text{O}(^6\text{Li}, \alpha)^{18}\text{F}$

$$Q_m = 6.051$$

Angular distributions have been measured at  $E(^6\text{Li}) = 5.5$  to  $34$  MeV [see (1983AJ01)] and at  $E(^6\text{Li}) = 48$  MeV (1984CO05;  $\alpha_0, \alpha_1, \alpha_4$ ). (1982FR15) report the excitation of a state at  $E_x = 4848 \pm 0.5$  keV which decays  $(35 \pm 4)\%$  to  $^{18}\text{F}^*(3.79)$  [ $E_\gamma = 1056.8 \pm 0.4$  keV] and  $(65 \pm 4)\%$  to  $^{18}\text{F}^*(1.12)$ . Alpha-gamma angular correlations are consistent with  $J^\pi = 5^-$ , and  $T = 0$  (1982FR15). See also (1986GL02) and (1986IC01).

24. (a)  $^{16}\text{O}(^{11}\text{B}, ^9\text{Be})^{18}\text{F}$

$$Q_m = -8.290$$

(b)  $^{16}\text{O}(^{13}\text{C}, ^{11}\text{B})^{18}\text{F}$

$$Q_m = -11.153$$

(c)  $^{16}\text{O}(^{14}\text{N}, ^{12}\text{C})^{18}\text{F}$

$$Q_m = -2.747$$

See (1983AJ01).

Table 18.29: States in  $^{18}\text{F}$  from  $^{16}\text{O}(^3\text{He}, p\gamma)^{18}\text{F}$  <sup>a</sup>

$E_x$ (keV) <sup>b</sup>	$l$ <sup>a</sup>	$J^\pi; T$ <sup>c</sup>	$K^\pi$ <sup>c</sup>
0	0	$1^+; 0$	$0^+$
$937.1 \pm 0.4$	2	$3^+; 0$	$0^+$
$1040.9 \pm 0.5$	0	$0^+; 1$	
$1080.1 \pm 0.5$		$0^-; 0$	$0^-$
$1119.0 \pm 0.6$	4	$5^+; 0$	$0^+$
$1701.4 \pm 0.7$	0	$1^+; 0$	$1^+$
$2099.9 \pm 0.6$		$2^-; 0$	$0^-$
$2523.4 \pm 0.7$	2	$2^+; 0$	$1^+$
$3061.2 \pm 0.5$	2	$2^+; 1$	
$3132.8 \pm 0.6$		$1^-; 0$	$1^-$
$3358.2 \pm 1.0$		$3^+; 0$	$1^+$
$3725.4 \pm 0.8$		$1^+; 0$	
$3790 \pm 0.9$		$3^-; 0$	$1^-$
$3838.4 \pm 0.7$	2	$2^+; 0$	
$4114.5 \pm 0.9$		$3^+; 0$	
$4225.8 \pm 0.7$		$2^{(-)}; 0$	$(1^-)$
$4361.0 \pm 0.7$		$1^{(+)}$	
$4398.1 \pm 0.7$		$3^-, 4^-; 0$ <sup>d</sup>	$(0^-)$

Table 18.29: States in  $^{18}\text{F}$  from  $^{16}\text{O}(^3\text{He}, p\gamma)^{18}\text{F}$  <sup>a</sup> (continued)

$E_x$ (keV) <sup>b</sup>	$l$ <sup>a</sup>	$J^\pi; T$ <sup>c</sup>	$K^\pi$ <sup>c</sup>	
$4652 \pm 2$	4	$4^+; 1$		
$4753 \pm 3$		$(0^+; 1)$		
$4860 \pm 2$		$1^{(-)}; 0$		
$4963.6 \pm 0.8$		$2^+; 1$		
$5297.6 \pm 1.5$		$4^+$		$1^+$
$5502 \pm 2$		$3^{(-)}; 0$		
$5603 \pm 2$		$1^-; 0 + 1$		
$5669 \pm 2$		$1^-; 0 + 1$		
$5785 \pm 3$		$2^-; 0$		
$6097.4 \pm 1.4$		$4^-; 0$		$1^-$
$6108 \pm 3$		$1, 2, 3^{(-)}; 0$		
$6138.3 \pm 1.0$		$0^+; 1$		
$6164.0 \pm 1.0$		$3^+; 1$		
$6241.2 \pm 1.0$		$3^-; 1$		
$6263 \pm 3$		$1^+$		
$6284.0 \pm 1.0$		$2^+; 0 + 1$		
$6310.5 \pm 0.8$		$3^+; 0$		
$6383 \pm 3$		$2^+; 0 + 1$		
$6480 \pm 2$		$3^+; (0)$		
$6567.0 \pm 1.5$	$5^+$	$1^+$		
$6643.0 \pm 1.5$	$2^-; 1$			
$6777 \pm 2$ <sup>c</sup>	$4^+$			
$6803.0 \pm 1.5$	$1^+, 2, 3^+; (0)$			
$6878 \pm 2$ <sup>c</sup>	$3^{(-)}, 4^-; (0)$			

<sup>a</sup> For earlier results derived from measurements of proton spectra and of  $\gamma$ -rays, see Table 18.18 in (1972AJ02). See also Tables 18.25 and 18.26 here.

<sup>b</sup> (1973RO03):  $\gamma$ -ray measurements.

<sup>c</sup> See Table 18.17 in (1978AJ03).

<sup>d</sup> See p. 179 of (1979KI12).

Table 18.30: Excited states of  $^{18}\text{F}$  from  $^{17}\text{O}(\text{p}, \gamma)^{18}\text{F}$  <sup>a</sup>

$E_x$ (keV)	$E_x$ (keV)
$937.18 \pm 0.06$	$3724.19 \pm 0.22$
$1041.55 \pm 0.08$	$3791.49 \pm 0.22$
$1080.54 \pm 0.12$	$3839.17 \pm 0.22$
$1121.36 \pm 0.15$	$4115.90 \pm 0.25$
$1700.81 \pm 0.18$	$4360.15 \pm 0.26$
$2100.61 \pm 0.10$	$5603.38 \pm 0.27$
$2523.35 \pm 0.18$	$5604.86 \pm 0.28$
$3061.84 \pm 0.18$	$5668 \pm 2$
$3133.87 \pm 0.15$	$6136.47 \pm 0.33$

<sup>a</sup> See also Table 18.31 here, and Table 18.17 in (1983AJ01).

25.  $^{17}\text{O}(\text{p}, \gamma)^{18}\text{F}$

$$Q_m = 5.607$$

Gamma-ray measurements lead to the very accurate  $E_x$  determinations for  $^{18}\text{F}$  states below 6.2 MeV: see Table 18.30. Observed resonances are displayed in Table 18.31; branching ratios, radiative widths and multipole mixing ratios are shown in Table 18.25; and  $\tau_m$  in Table 18.26.

The direct capture cross section has been studied for  $E_p = 0.3$  to 1.9 MeV:  $^{18}\text{F}^*(5.603, 5.605, 5.668, 5.786 \text{ MeV})$  have  $J^\pi = 1^+, 1^-, 1^-$  and  $2^-$ . The  $1^-$  states have mixed isospin. For astrophysical work, see the thermonuclear reaction rate tables in (1985CA41) and the analytical expression presented in (1988CA26). See also (1978AJ03, 1983AJ01, 1987AJ02).

26.  $^{17}\text{O}(\text{p}, \text{n})^{17}\text{F}$

$$Q_m = -3.543$$

$$E_b = 5.607$$

Observed resonances are displayed in Table 18.31. Analyzing power measurements are reported at  $E_p = 135$  MeV (1983PUZZ;  $n_0$ ).

For astrophysics-related work see the thermonuclear reaction rate tables of (1985CA41) and the analytical expressions of (1988CA26).

27.  $^{17}\text{O}(\text{p}, \text{p}')^{17}\text{O}$

$$E_b = 5.607$$

The elastic scattering has been studied for  $E_p = 0.5$  to 13 MeV [see (1978AJ03, 1983AJ01)]: observed anomalies are displayed in Table 18.31. Analyzing powers have been measured at  $E_p = 89.7$  MeV (1985VO12).

28.  $^{17}\text{O}(\text{p}, \text{t})^{15}\text{O}$ 

$$Q_{\text{m}} = -11.325$$

$$E_{\text{b}} = 5.607$$

Analyzing powers have been reported at  $E_{\text{p}} = 89.7$  MeV for the triton groups to a number of  $^{15}\text{O}$  states (1985VO12).

29.  $^{17}\text{O}(\text{p}, \alpha)^{14}\text{N}$ 

$$Q_{\text{m}} = 1.192$$

$$E_{\text{b}} = 5.607$$

The yield of  $\alpha_0$  shows a number of resonances for  $E_{\text{p}} = 0.49$  to 3.0 MeV: see Table 18.31. The R-matrix fit of (1979KI13), obtained using data from  $E_{\text{p}} = 400$  to 1400 keV, confirms the earlier result [see, e.g., reaction 31 in (1978AJ03)] that a significant quantity of  $^{17}\text{O}$  is burned up in the  $(\text{p}, \gamma)$  rather than in the  $(\text{p}, \alpha)$  reaction for a wide range of stellar temperatures (1979KI13). See also (1987AJ02, 1987AS05).

Table 18.31: Resonances in  $^{17}\text{O} + \text{p}$  <sup>a</sup>

$E_{\text{p}}$ (keV)	Particles out	$\Gamma_{\text{c.m.}}$ (keV)	$(2J+1)\Gamma_{\gamma}\Gamma_{\text{p}}/\Gamma$ (eV)	$J^{\pi}; T$	$E_{\text{x}}$ (MeV $\pm$ keV)
$517.0 \pm 1.0$	$\gamma, \alpha_0$	$0.24 \pm 0.03$	$0.26 \pm 0.05$	$4^{-}; 0$	6.095
525	$\alpha_0$	$0.034 \pm 0.003$		$(1^{+})$	6.102
$561.2 \pm 1.0$	$\gamma$	$\leq 1$	$2.2 \pm 0.6$	$0^{+}; 1$	6.136
$587.1 \pm 1.0$	$\gamma, \text{p}_0, \alpha_0$	$14 \pm 0.5$	$6.7 \pm 1.8$	$3^{+}; 1$	6.161
$670.5 \pm 1.0$	$\gamma, \text{p}_0, \alpha_0$	$0.19 \pm 0.03$	<sup>c</sup>	$3^{-}; 0+1$	6.239
673.0	$\gamma, \alpha_0$	$0.18 \pm 0.04$	<sup>c</sup>	$3^{-}; 0+1$	6.242
$690 \pm 4$	$\alpha_0$	$0.60 \pm 0.12$	$\leq 0.02$	$1^{+}; 0$	6.258
$714.2 \pm 1.0$	$\gamma, \text{p}_0, \alpha_0$	$10.0 \pm 0.5$	$9.1 \pm 2.3$	$2^{+}; 1$	6.281
$741 \pm 2$	$\gamma, \text{p}_0, \alpha_0$	$0.95 \pm 0.14$	$0.64 \pm 0.17$	$3^{+}; 0$	6.306
$826 \pm 2$	$\gamma, \alpha_0$	$0.40 \pm 0.09$	$0.60 \pm 0.18$	$2^{+}; 0+1$	6.386
$926 \pm 2$	$\gamma, \alpha_0$	$0.40 \pm 0.10$	$0.36 \pm 0.15$	$3^{+}; 0$	6.481
1015	$\alpha_0$	$0.56 \pm 0.13$	$\leq 0.0023$	$5^{+}; 0$	6.565
1090	$\alpha_0$	$80 \pm 2$		1	6.635
$1098.4 \pm 0.4$	$\gamma, \alpha$	$0.60 \pm 0.07$	$4.3 \pm 1.2$	$2^{-}; 1$	6.6439
$1101 \pm 4$	$\alpha_0$	$89 \pm 5$			6.646
$1240 \pm 2$ <sup>b</sup>	$\gamma, \text{p}_0, \alpha_0$	$9.2 \pm 1.0$	$2.8 \pm 0.7$	$4^{+}; 0$	6.777
1270	$\gamma, \text{p}_0$	$\leq 2$	$0.54 \pm 0.20$	$1^{+}, 2, 3^{+}; 0$	$6.8031 \pm 1.5$
$1274 \pm 5$	$\alpha_0$	$88 \pm 2$		$2^{-}$	6.809

Table 18.31: Resonances in  $^{17}\text{O} + \text{p}$  <sup>a</sup> (continued)

$E_p$ (keV)	Particles out	$\Gamma_{\text{c.m.}}$ (keV)	$(2J + 1)\Gamma_\gamma\Gamma_p/\Gamma$ (eV)	$J^\pi; T$	$E_x$ (MeV $\pm$ keV)
1276	$\alpha_0$	$3.0 \pm 0.5$		(2 <sup>+</sup> )	6.811
1338	$\alpha_0$	$5.0 \pm 1.0$		(3 <sup>-</sup> )	6.870
$1345 \pm 3$	$\gamma, \alpha_0$	$\leq 2$	$1.0 \pm 0.4$	3, 4 <sup>-</sup> ; 0	6.876
$1687.5 \pm 1$	$\alpha_0$	6.5	3.9	(4 <sup>+</sup> ); 0	7.199
$1738 \pm 2$	$\alpha_0$	46.5	8.8	(1 <sup>+</sup> ); 0	7.247
$1784 \pm 2$	$p_0, \alpha_0$	38	47	3 <sup>-</sup>	7.291
$1810 \pm 4$	$\alpha_0$	52	8.5	(3 <sup>-</sup> ; 0)	7.315
$1832.5 \pm 1$	$\gamma, p_0, p_1$	$16 \pm 2$	<sup>d</sup>	1 <sup>-</sup> ; 1	7.336
$1906 \pm 2$	$p_0, p_1$	$14.6 \pm 1.4$		1 <sup>+</sup>	7.406
$1950 \pm 10$	$\alpha_0$	140	5.6		7.447
$1957 \pm 2$	$p_0$	6		1 <sup>-</sup>	7.454
$1983 \pm 2$	$\gamma, p_1, \alpha_0$	$12 \pm 3$	1.5	(2)	7.478
( $1990 \pm 2$ )	$p_0$	32		(1 <sup>-</sup> )	(7.485)
$2012 \pm 2$	$p_0, \alpha_0$	$12 \pm 2$	7.2	4 <sup>-</sup>	7.506
$2020 \pm 2$	$\gamma$	$\leq 4$			7.513
$2036 \pm 2$	$\gamma, p_0, p_1, \alpha_0$	$16.5 \pm 3.0$	5.5 <sup>e</sup>	2 <sup>-</sup> ; 1	7.528
$2040 \pm 5$	$p_1, \alpha_0$	75			7.532
$2064 \pm 2$	$p_0$	30		(1 <sup>-</sup> )	7.555
$2095 \pm 2$	$\gamma, p_0, p_1, \alpha_0$	$9 \pm 2$	3.7 <sup>f</sup>	<sup>g</sup>	7.584
$2202 \pm 2$	$p_0, p_1, \alpha_0$	$36 \pm 4$	25.1	3 <sup>+</sup> , 4 <sup>+</sup> <sup>g</sup>	7.685
$2248 \pm 4$	$p_1, \alpha_0$	$66 \pm 5$	28.2	$\geq 1$	7.729
$2284 \pm 4$	$p_1$	70			7.763
$2406 \pm 3$	$p_1, \alpha_0$	20	24.4	$\geq 2$	7.878
$2429 \pm 2$	$\alpha_0$	38	42	(2 <sup>-</sup> )	7.899
$2473 \pm 12$	$\alpha_0$	112	80	(1 <sup>+</sup> )	7.941
$2603 \pm 6$	$p_1, \alpha_0$	60	11	$\geq 4$	8.064
$2657 \pm 8$	$p_1$	96			8.115
$2757 \pm 2$	$p_0, \alpha_0$	52	63	2 <sup>-</sup>	8.209
$2788 \pm 2$	$p_0$	20		4 <sup>+</sup>	8.238
2828	$\alpha_0$	$\simeq 50$			8.370

Table 18.31: Resonances in  $^{17}\text{O} + \text{p}$  <sup>a</sup> (continued)

$E_p$ (keV)	Particles out	$\Gamma_{\text{c.m.}}$ (keV)	$(2J + 1)\Gamma_\gamma\Gamma_p/\Gamma$ (eV)	$J^\pi; T$	$E_x$ (MeV $\pm$ keV)
$3915 \pm 20$	n	95			9.302
$(4163 \pm 20)$	n	19			(9.536)
$4235 \pm 10$	n	33			9.604
$4330 \pm 10$	n	33			9.694
$4490 \pm 20$	n	$\simeq 100$			9.845
$(4790 \pm 10)$	n	28			(10.128)
$4900 \pm 20$	n	$\simeq 140$			10.232

<sup>a</sup> For references see Tables 18.18 in (1978AJ03, 1983AJ01).

<sup>b</sup> See footnote <sup>d</sup> in Table 18.18 (1978AJ03).

<sup>c</sup> This corresponds to a doublet of  $3^-$ , mixed isospin states, separated by  $2.09 \pm 0.04$  keV.  $\omega\gamma_{p,\gamma} = 2.04 \pm 0.45$  eV for the lower resonance and  $1.16 \pm 0.26$  eV for the higher one.

<sup>d</sup>  $\Gamma_\gamma = 3.5 \pm 1.0$  eV.

<sup>e</sup>  $\Gamma_\gamma = 0.44 \pm 0.10$  eV.

<sup>f</sup>  $\Gamma_\gamma = 0.11 \pm 0.03$  eV.

<sup>g</sup> Assumed to be unresolved.

Measurements (1989BO01; see  $^{14}\text{N}(\alpha, \gamma)^{18}\text{F}$  reaction) of the first level ( $J^\pi = 1^-$ ) of  $^{18}\text{F}$  above the proton threshold determined  $E_x = 5672.57 \pm 0.32$  keV. This result and a new value for the proton width of this level deduced from  $^{17}\text{O}(^3\text{He}, \text{d})^{18}\text{F}$  measurements (1989LA19) lead to substantial changes in the stellar reaction rate for  $^{17}\text{O}(\text{p}, \alpha)^{14}\text{N}$ . [See discussion in (1989LA19).] A direct search for the  $E_x = 70$  keV resonance ( $E_p = 5672.57 \pm 0.32$  keV) was carried out and an upper limit for the resonance strength ( $\omega\gamma \leq 8 \times 10^{-10}$  eV) was reported in (1992BE21).

$$30. \ ^{17}\text{O}(^3\text{He}, \text{d})^{18}\text{F} \quad Q_m = 0.113$$

At  $E(^3\text{He}) = 15$  MeV DWBA analysis of angular distributions of deuteron groups corresponding to states of  $^{18}\text{F}$  with  $E_x < 5$  MeV have led to  $J^\pi$  values and spectroscopic information: see (1972AJ02). Proton widths of states near the proton threshold were measured by (1989LA19). See also (1987ER05).

$$31. \ ^{17}\text{O}(\alpha, \text{t})^{18}\text{F} \quad Q_m = -14.207$$

Table 18.32: Some states in  $^{18}\text{F}$  from  $^{17}\text{O}(\alpha, t)$  <sup>a</sup>

$E_x$ (MeV) <sup>b</sup>	$J^\pi$ <sup>b</sup>	$\sigma_{\text{int}}$ (mb) <sup>c</sup>
0.0	$1^+$	0.26
0.94	$3^+$	0.41
1.04	$0^+, T = 1$	
1.12	$5^+$	1.92
2.52	$2^+$	0.02
3.06	$2^+, T = 1$	0.32
3.72	$1^+$	0.15
4.12	$3^+$	0.43
4.65	$4^+, T = 1$	0.61
7.44	$(5^-)$ <sup>d</sup>	0.09
9.02	$(5^-, T = 1)$ <sup>d</sup>	0.09
9.58	$(6^-)$ <sup>d</sup>	0.19
12.75	$(6^-, T = 1)$	0.03
14.65	$(7^+)$ <sup>d</sup>	0.07
15.8	$(6^-, T = 1)$ <sup>d</sup>	0.03

<sup>a</sup> (1992YA08);  $E_\alpha = 65$  MeV.

<sup>b</sup>  $E_x$  and  $J^\pi$  values from (1987AJ02).

<sup>c</sup> Integrated cross section. See Tables III and IV in (1992YA08) for spectroscopic factors.

<sup>d</sup>  $J^\pi$  value assumed in analysis by (1992YA08).



Measurements and DWBA analysis of differential cross sections at  $E_\alpha = 65$  MeV are reported in (1992YA08). Measured level energies and spectroscopic information are included in Table 18.32.

$$32. {}^{17}\text{O}({}^{12}\text{C}, {}^{11}\text{B}){}^{18}\text{F} \quad Q_m = -10.350$$

See (1983AJ01).

$$33. {}^{18}\text{O}(\pi^+, \pi^0){}^{18}\text{F} \quad Q_m = 2.939$$

See (1983AS01, 1984AS05, 1989LE1L).

$$34. {}^{18}\text{O}(\text{p}, \text{n}){}^{18}\text{F} \quad Q_m = -2.437$$

(1983AN05) have studied the distribution of Gamow-Teller (GT) strength. At  $E_p = 135$  MeV angular distributions have been studied to the  $0^+$  state at 1.04 MeV and to the  $1^+$  states  ${}^{18}\text{F}^*(0, 1.70, 3.72, 4.36, 6.26$  MeV) as well as to possible  $1^+$ ;  $T = 1$  groups at  $E_x = 9.9, 10.9$  and 11.9 MeV. 82% of the observed strength lies in the ground state group and 5.5% in the  $T = 1$  states. The observed GT strength is  $\approx \frac{2}{3}$  of that expected from the simple sum rule (1983AN05). Multipole decomposition of data from measurements at  $E_p = 494$  MeV is reported in (1994ME07). See also (1978AJ03, 1987AJ02).

More recently the (p, n) reaction as a probe of beta decay strength is discussed in (1987GO1V, 1987TA13, 1988MA53). See also (1989RA1G). Studies of stretched state excitation are described in (1986AN1E) and measurement of spin observables at  $E_p = 135$  MeV are discussed in (1989WAZZ, 1990WAZT). Total cross sections for  ${}^{18}\text{O}$  production from  ${}^{18}\text{O}(\text{p}, \text{n})$  were measured by (1990WA10). See (1988HI1F, 1991GU05) for related applications.

$$35. {}^{18}\text{O}({}^3\text{He}, \text{t}){}^{18}\text{F} \quad Q_m = -1.674$$

At  $E({}^3\text{He}) = 16$  MeV, the triton spectrum is dominated by strong groups to  ${}^{18}\text{F}^*(0, 0.94)$  and to the  $0^+$  and  $2^+$ ,  $T = 1$  states  ${}^{18}\text{F}^*(1.04, 3.06)$ . Angular distributions have been studied to these and many other states at this energy and at  $E({}^3\text{He}) = 17.3$  MeV.  $A_y$  measurements for  $t_0$  have been reported at  $E({}^3\text{He}) = 33$  MeV. See (1983AJ01) for references.

$$36. {}^{18}\text{O}({}^6\text{Li}, {}^6\text{He}){}^{18}\text{F} \quad Q_m = -5.163$$

Table 18.33: Branching in  $^{18}\text{Ne}(\beta^+)^{18}\text{F}$  <sup>a</sup>

Decay to $^{18}\text{F}^*$ (MeV)	$J^\pi; T$	$E_{\gamma_0}$ (keV)	Branch <sup>b</sup> (%)	$\log f_0 t$ <sup>c</sup>
0	$1^+; 0$		$92.11 \pm 0.21$	$3.096 \pm 0.004$
1.04 <sup>d</sup>	$0^+; 1$	$1041.5 \pm 0.3$	$7.70 \pm 0.21$	$3.473 \pm 0.013$
1.08 <sup>d</sup>	$0^-; 0$	$1080.76 \pm 0.13$ <sup>b</sup>	$(2.07 \pm 0.28) \times 10^{-3}$	$7.012 \pm 0.059$
1.70	$1^+; 0$	$1699.9 \pm 0.3$ <sup>e</sup>	$0.188 \pm 0.006$	$4.477 \pm 0.015$

<sup>a</sup> For the earlier work see Tables 18.19 in (1983AJ01) and 18.20 in (1978AJ03).

<sup>b</sup> (1983AD03). See also (1982HE04).

<sup>c</sup> Based on  $\tau_{1/2} = 1672 \pm 8$  ms: see (1983AD03).

<sup>d</sup> The splitting of the  $0^+$  and  $0^-$  states is  $39.20 \pm 0.11$  keV (1983AD03).

<sup>e</sup> And  $659.2 \pm 0.3$  keV for the  $\gamma$ -ray to  $^{18}\text{F}^*(1.04)$  (1982HE04).

The reaction was studied at  $E(^6\text{Li}) = 156$  MeV by (1990MO13). Evaluated cross sections for Gamow-Teller transitions at  $0^\circ$  and strengths for analogous beta decays were compared.

$$37. \ ^{18}\text{Ne}(\beta^+)^{18}\text{F} \quad Q_m = 4.446$$

The half-life of  $^{18}\text{Ne}$  is  $1672 \pm 8$  ms [see  $^{18}\text{Ne}$ ]. The decay is to  $^{18}\text{F}^*(0, 1.04, 1.08, 1.70$  MeV): see Table 18.33 and reaction 1 under  $^{18}\text{Ne}$ .

$$38. \ ^{19}\text{F}(\gamma, n)^{18}\text{F} \quad Q_m = -10.431$$

Cross sections have been reported to 30 MeV for the transitions to  $^{18}\text{F}^*(0.94, 1.04, 1.08, 3.06, 3.13, 4.75$  MeV): see (1983AJ01).

Cross sections for the  $(\gamma, n_0)$  photoneutron reaction were measured between  $48^\circ$  and  $139^\circ$  for  $E_\gamma = 15\text{--}25$  MeV by (1989KU10). The E1 absorption strength was deduced.

$$39. \ ^{19}\text{F}(n, 2n)^{18}\text{F} \quad Q_m = -10.431$$

Cross sections have been measured at  $E_n = 18, 21, 23, 25,$  and  $27$  MeV (1991HA17).

$$40. \ ^{19}\text{F}(p, d)^{18}\text{F} \quad Q_m = -8.207$$

Table 18.34:  $\gamma$ -ray intensities in  $^{18}\text{Ne}(\beta^+)^{18}\text{F}$  <sup>a</sup>

$E_\gamma$ (keV)	$E_i$ (keV)	$E_f$ (keV)	$I_\gamma$ <sup>b</sup>
$659.0 \pm 0.2$	1701	1042	$0.135 \pm 0.005$
$1041.55 \pm 0.08$	1042	0	$7.83 \pm 0.21$
$1080.76 \pm 0.13$	1081	0	$0.00226 \pm 0.00021$
$1700.81 \pm 0.18$	1701	0	$0.0538 \pm 0.0018$

<sup>a</sup> (1983AD03).

<sup>b</sup>  $\gamma$ -ray intensities are per 100 parent decays.

Angular distributions have been reported to many states of  $^{18}\text{F}$  with  $E_x \leq 6$  MeV: see Table 18.20 in (1983AJ01). See also (1987AJ02). Spectroscopic factors derived from measurements of  $E_p = 18.6$  MeV are discussed in (1987VA28). See also (1989VAZM).

41.  $^{19}\text{F}(\text{d}, \text{t})^{18}\text{F}$   $Q_m = -4.174$

See (1972AJ02, 1978AJ03), and see (1989VAZM) for cross section measurements and deduced level energies and spectroscopic factors. A recent measurement of total cross sections at  $E_d = 5\text{--}12$  MeV (1993AB18) detected eight resonances with widths  $\Gamma \approx 200\text{--}400$  keV.

42.  $^{19}\text{F}(^3\text{He}, \alpha)^{18}\text{F}$   $Q_m = 10.146$

See (1978AJ03, 1987VA11, 1988GOZB), and see (1989VAZM) for cross section measurements and deduced level energies and spectroscopic factors.

43.  $^{20}\text{Ne}(\text{p}, ^3\text{He})^{18}\text{F}$   $Q_m = -15.557$

See (1978AJ03).

44.  $^{20}\text{Ne}(\text{d}, \alpha)^{18}\text{F}$   $Q_m = 2.796$

At  $E_d = 11$  MeV  $\alpha$ -groups are observed to many states of  $^{18}\text{F}$  with  $E_x < 7$  MeV. Weak or absent (each  $\leq 0.3\%$  of the total yield at  $30^\circ$ ) are the groups corresponding to  $^{18}\text{F}^*(1.04, 3.06,$

4.66, 4.74, 4.96 MeV):  $T = 1$ . Measurements of the TAP for  $E_d = 10.25$  to 12.0 MeV leads to assignments of  $2^-$ ,  $1^+$ ,  $0^+$ ,  $1^-$ ,  $1^+$ ,  $3^+$ ,  $3^+$  to  $^{18}\text{F}^*$ (4.23, 4.36, 4.75, 4.86, 5.603, 6.16, 6.48 MeV). See (1972AJ02, 1978AJ03, 1983AJ01) for references and for other results and (1987HI1B) for applications. Use of this reaction for  $^{18}\text{F}$  production is discussed in (1991GU05).



See (1987GOZX).

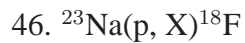

The  $^{18}\text{F}$  yield from protons on  $^{23}\text{Na}$  at  $E_p = 20$ –67.5 MeV was measured (1992LA25) and cross sections were deduced.



See (1984NE1A).



Cross sections have been measured for  $E(^{16}\text{O}) = 13.6$  GeV/nucleon by (1993CU05).

$^{18}\text{Ne}$   
(Figs. 4 and 5)

GENERAL: See Table 18.35.

For  $B(E2)$  of  $^{18}\text{Ne}^*$  (1.89) and other parameters see (1987RA01) and Table 2 here.

1.  $^{18}\text{Ne}(\beta^+)^{18}\text{F}$   $Q_m = 4.446$

The half-life of  $^{18}\text{Ne}$  is  $1672 \pm 8$  ms: see (1978AJ03) and (1983AD03). The decay is primarily to  $^{18}\text{F}^*(0, 1.04, 1.70 \text{ MeV})$ . In addition there is an extremely weak branch [ $(2.07 \pm 0.28) \times 10^{-3}\%$ ] to  $^{18}\text{F}^*$  (1.08 MeV) [ $J^\pi = 0^-; T = 0$ ] (1983AD03): see Table 18.33 for the parameters of the decay. The parity mixing in the  $^{18}\text{F}^*(1.04, 1.08) 0^+-0^-$  doublet has been studied by (1983AD03). It has been proposed as a probe of  $T$ -odd nuclear forces (1992HE12). See also (1982HE04). For the earlier work see (1983AJ01, 1987AJ02).

2.  $^{12}\text{C}(^{12}\text{C}, ^6\text{He})^{18}\text{Ne}$   $Q_m = -22.913$

This reaction was studied at  $^6\text{He}$  angles from  $0^\circ$  to  $10^\circ$  with a magnetic spectrometer (1992HAZZ). New levels at  $E_x > 6$  MeV, including  $^{18}\text{Ne}(6.15, 7.35 \text{ MeV})$ , were found. Astrophysical implications are discussed.

3.  $^{14}\text{O}(\alpha, \gamma)^{18}\text{Ne}$   $Q_m = 5.112$

The thermonuclear reaction rates for this reaction have been estimated (1987WI11) using information from the isobaric analog  $^{18}\text{O}$ . A new  $^{18}\text{Ne}$  level at  $E_x = 6.15$  MeV (see  $^{16}\text{O}(^3\text{He}, n)$ ) has been observed (1990GAZW) which may play a role in  $^{14}\text{O} + \alpha$  burning. See also (1988CA26).

4.  $^{14}\text{O}(\alpha, p)^{17}\text{F}$   $Q_m = 1.190$

This reaction is considered important in the generation of  $Z \geq 10$  nuclei from products in the hot CNO cycle. Microscopic multichannel calculations for this reaction are discussed in (1988FU02, 1989FU01).

5.  $^{16}\text{O}(^3\text{He}, n)^{18}\text{Ne}$   $Q_m = -3.196$

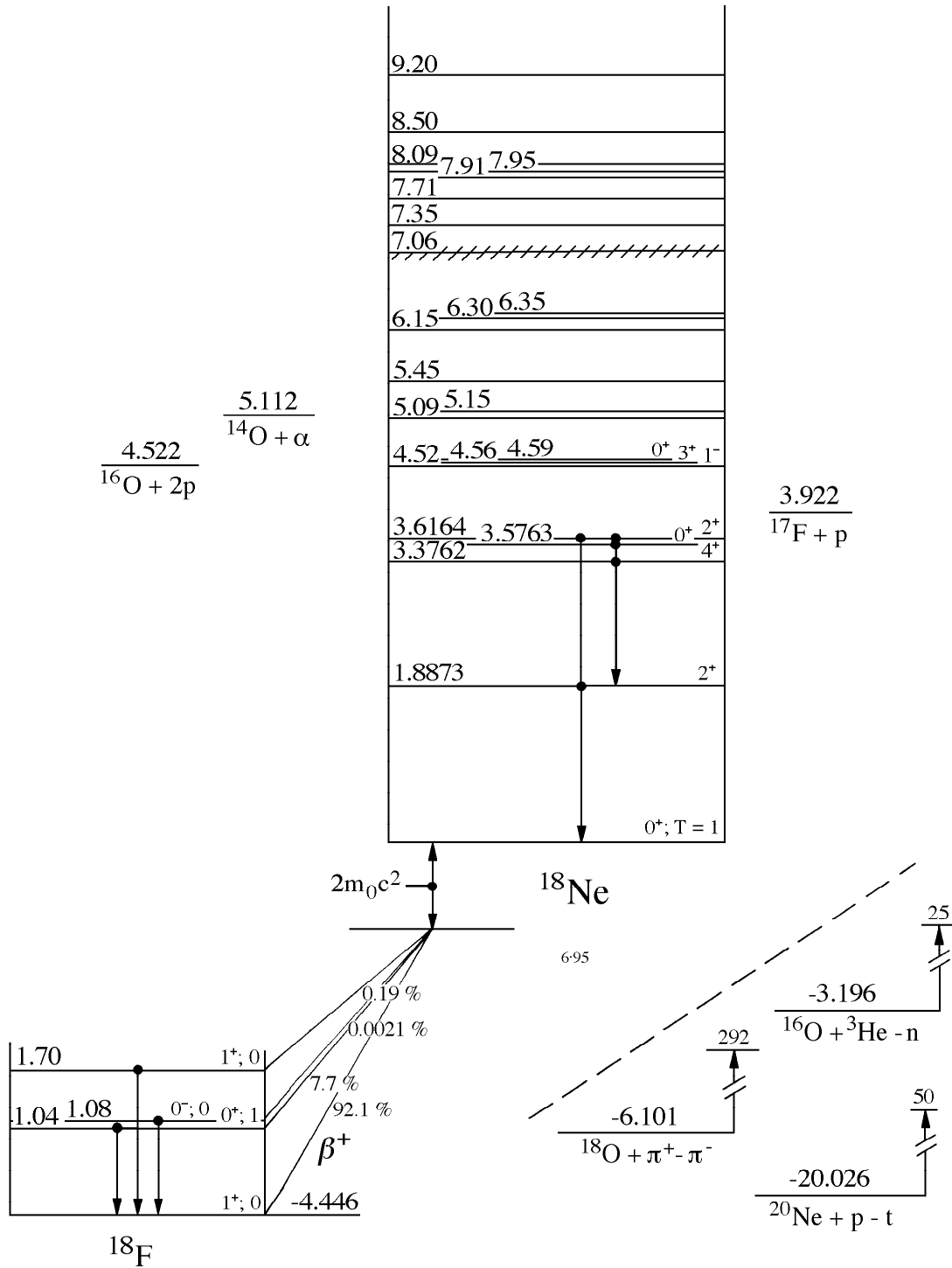

Fig. 4: Energy levels of  $^{18}\text{Ne}$ . For notation see Fig. 2.

Table 18.35:  $^{18}\text{Ne}$  – General

---

Reference	Description
Reviews:	
1987LE1B	Strong interaction studies via meson-nucleus reactions
1987RA1D	Nuclear processes and accelerated particles in solar flares
1993EN03	Strengths of $\gamma$ -ray transitions in $A = 5$ –44 nuclei
Other articles:	
1987BE1I	Search for a nucleon-participant multiplicity effect on anomalous fragment production
1987BU12	An ISOL/post-accelerator facility for nuclear astrophysics at TRIUMF
1987CO31	Simple parametrization for low energy octupole modes of s-d shell nuclei
1987KA39	Delta-hole approach to pion double charge exchange (DCX) reactions
1987PA1H	Anomalous behavior of low energy analog double charge exchange
1988MA1Q	Identification of one glue-like mechanism of the $\Lambda$ -hyperon in hypernuclei
1988YU04	Contribution of the 2nd kind of meson exchange current to $^{18}\text{O}(\pi^+, \pi^-)^{18}\text{Ne}(\text{g.s.})$
1989BA92	Strangeness production in relativistic heavy-ion collisions
1989CH1P	1s-0d effective interactions of isospin triplet & $^{18}\text{Ne}$ - $^{18}\text{O}$ Coulomb displacement energies
1989RA16	Predxns. from systematics & tabulation of $B(E2; 0_1^+ \rightarrow 2_1^+)$ values for even-even nucl.
1989TR18	2-nucleon and 4-nucleon clusters in light & heavy nuclei
1990BR13	Empir. p-n interactions: global trends, configuration sensitivity & $N = Z$ enhancements
1990BR26	Shell-model calcs. of isospin-forbidden $\beta$ -delayed proton emission of isobaric analog state
1990LO11	Self-consistent calculations of light nuclei
1990MAZW	Hybrid quark hadron model of DCX in the delta resonance region (A)
1990PO04	New method of determining masses & quantum characteristics of light nuclei
1992AV03	The proton-neutron interaction & mass calcs. for nuclei with $Z > N$
1994CI02	Specific heat and shape transitions in light sd nuclei

---

(A) denotes that only an abstract was available for this reference.

Table 18.36: Energy levels of  $^{18}\text{Ne}$  <sup>a</sup>

$E_x$ (MeV $\pm$ keV)	$J^\pi; T$	$\tau$ or $\Gamma_{\text{c.m.}}$	Decay	Reactions
0	$0^+; 1$	$\tau_{1/2} = 1672 \pm 8$ ms	$\beta^+$	1, 5, 9, 10
$1.8873 \pm 0.2$	$2^+$	$\tau_{\text{m}} = 0.67 \pm 0.06$ ps	$\gamma$	5, 9, 10
$3.3762 \pm 0.4$	$4^+$	$\tau_{\text{m}} = 4.4 \pm 0.6$ ps	$\gamma$	5, 7, 8, 10
$3.5763 \pm 2.0$	$0^+$	$\tau_{\text{m}} = 4 \pm 2$ ps	$\gamma$	5, 10
$3.6164 \pm 0.6$	$2^+$	$\tau_{\text{m}} = 63_{-20}^{+30}$ fs	$\gamma$	5, 10
$4.519 \pm 8$	$1^-$	$\Gamma \leq 20$ keV	(p)	5, 10
$4.561 \pm 9$	$3^+$			5
$4.590 \pm 8$	$0^+$	$\Gamma \leq 20$ keV	(p)	5, 10
$5.090 \pm 8$	$(2^+, 3^-)$	$\Gamma = 40 \pm 20$ keV	(p)	5, 10
$5.146 \pm 7$	$(2^+, 3^-)$	$\Gamma = 25 \pm 15$ keV		5, 10
$5.453 \pm 10$		$\Gamma \leq 50$ keV		10
$6.15^{\text{b, c}}$	$(1^-)$			2, 3
$6.297 \pm 10$	$(4^+)$	$\Gamma \leq 60$ keV		5, 10
$6.353 \pm 10$		$\Gamma \leq 60$ keV		10
$7.059 \pm 10$	$(1^-, 2^+)$	$\Gamma = 180 \pm 50$ keV		5
$7.35^{\text{c}}$				2
$7.713 \pm 10$		$\Gamma \leq 50$ keV		5, 10
$7.910 \pm 10$	$(1^-, 2^+)$	$\Gamma \leq 50$ keV		5
$7.950 \pm 10$		$\Gamma \leq 60$ keV		10
$8.086 \pm 10$		$\Gamma \leq 50$ keV		5
$8.500 \pm 30$		$\Gamma \leq 120$ keV		5
$9.201 \pm 9$		$\Gamma \leq 50$ keV		10

<sup>a</sup> See also Table 18.37.

<sup>b</sup> (1990GAZW).

<sup>c</sup> (1992HAZZ). This work reports the observation of several new levels in the region  $E_x > 6$  MeV.



See Table 18.38. See also (1983AJ01).

Recent work reported in (1991GA03) found that the  $3^+$  level in  $^{18}\text{Ne}$  predicted by (1988WI08) occurs at  $E_x = 4.561 \pm 0.009$  MeV. Astrophysical consequences are discussed. New levels in  $^{18}\text{Ne}$  at  $E_x \geq 6$  MeV observed in  $^{16}\text{O}(^3\text{He}, n)$  were reported in (1990GAZW). [See discussion under  $^{14}\text{O}(\alpha, \gamma)^{18}\text{Ne}$ .] See also (1989GAZW, 1990GAZR). For applied work related to this reaction see (1991GU05, 1992DI04).



See (1991GU05) for measurements at  $E_\alpha = 40$  MeV.

Table 18.37: Branching ratios and lifetimes of  $^{18}\text{Ne}$  states <sup>a</sup>

$E_i$ (MeV)	$J_i^\pi$	$E_f$ (MeV)	Branch (%)	$\tau_m$ (ps)
1.89	$2^+$	0	100	$0.67 \pm 0.06$
3.38	$4^+$	1.89	100 <sup>b</sup>	$4.4 \pm 0.6$
3.58	$0^+$	1.89	100 <sup>c</sup>	$4 \pm 2$
3.62	$2^+$	0	$9 \pm 2$	
		1.89	$91 \pm 2$ <sup>d</sup>	$0.063^{+0.030}_{-0.020}$

<sup>a</sup> For references see Table 18.24 in (1978AJ03).

<sup>b</sup> Ground state decay is  $< 1\%$ .

<sup>c</sup> Ground state decay is  $< 5\%$ .

<sup>d</sup> The mixing ratio,  $\delta$ , is consistent with 0.

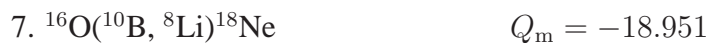

At  $E(^{10}\text{B}) = 100$  MeV, the angular distribution to  $^{18}\text{Ne}^*(3.38)$  [ $(d_{5/2})_{4^+}^2$  state], which is preferentially populated, has been studied.  $^{18}\text{Ne}^*(1.89)$  is also observed (see (1983AJ01). See also (1983OS07).



Measurements at  $E(^{12}\text{C}) = 480$  MeV are reported in (1988KR11, 1988ME10). The  $4^+$  level at  $E_x = 3.38$  MeV is observed.

Table 18.38: States in  $^{18}\text{Ne}$  from  $^{16}\text{O}(^3\text{He}, n)$  and  $^{20}\text{Ne}(p, t)$  <sup>a</sup>

$E_x$ (MeV $\pm$ keV)		$\Gamma_{c.m.}$ <sup>b</sup> (keV)	$J\pi$ <sup>a, b</sup>
A	B		
0			$0^+$
$1.8873 \pm 0.2$	$1.886 \pm 10$		$2^+$
$3.3762 \pm 0.4$	$3.375 \pm 10$		$4^+$
$3.5763 \pm 2.0$	$3.580 \pm 10$		$0^+$
$3.6164 \pm 0.6$	$3.612 \pm 10$		$2^+$
$4.513 \pm 13$	$4.522 \pm 10$	$\leq 20$	$1^-$
$4.561 \pm 9$ <sup>c</sup>		$25$ <sup>c</sup>	$3^+$ <sup>c</sup>
$4.587 \pm 13$	$4.592 \pm 10$	$\leq 20$	$0^+$
$5.075 \pm 13$	$5.099 \pm 10$	$40 \pm 20$	$(2^+, 3^-)$
$5.141 \pm 10$	$5.151 \pm 10$	$25 \pm 15$	$(2^+, 3^-)$
	$5.453 \pm 10$	$\leq 50$	
$6.291 \pm 30$ <sup>d</sup>	$6.297 \pm 10$	$\leq 60$	$(4^+)$
	$6.353 \pm 10$	$\leq 60$	
$7.062 \pm 12$ <sup>a</sup>		$180 \pm 50$	$(1^-, 2^+)$
$7.712 \pm 20$	$7.713 \pm 10$	$\leq 50$	
$7.915 \pm 12$ <sup>a</sup>		$\leq 50$	$(1^-, 2^+)$
	$7.949 \pm 10$	$\leq 60$	
$8.100 \pm 14$ <sup>a</sup>		$\leq 50$	
$8.50 \pm 30$		$\leq 120$	
	$9.198 \pm 10$	$\leq 50$	

A:  $^{16}\text{O}(^3\text{He}, n)^{18}\text{Ne}$ : for references see Table 18.23 (1978AJ03) and (1981NE09).

B:  $^{20}\text{Ne}(p, t)^{18}\text{Ne}$ : (1981NE09).

<sup>a</sup> See also Table 18.23 in (1978AJ03).

<sup>b</sup> (1981NE09).

<sup>c</sup> (1991GA03). The width  $\Gamma = 25$  keV is estimated from a Woods Saxon calculation.

<sup>d</sup>  $\Gamma = 180 \pm 60$  keV.

9.  $^{18}\text{O}(\pi^+, \pi^-)^{18}\text{Ne}$   $Q_m = -6.101$

Angular distributions have been studied at  $E(\pi^+) = 164$  and  $292$  MeV [see (1983AJ01)] and at  $48.3$  MeV (1985AL15; to  $^{18}\text{Ne}_{g.s.}$ ) and  $100$  to  $292$  MeV (1985SE08; to  $^{18}\text{Ne}_{g.s.}$ ). The excitation functions for production of  $^{18}\text{Ne}^*(0, 1.89)$  have been measured for  $E(\pi^+) = 80$  to  $292$  MeV: see (1983AJ01, 1985SE08). See also (1987AJ02).

The behavior of double charge exchange (DCX) cross sections at low energies ( $50 \pm 30$  MeV) was reviewed in (1987PA1H, 1988SE1A, 1989BA1R). See also the review of (1989ST1H). Measurements at energies of  $300$ – $500$  MeV above the  $\Delta(1232)$  resonance were reported in (1989WI02). More recently a search for an  $\eta$  bound state in this reaction is described in (1992JOZZ, 1993JO03).

The contribution of the two-nucleon pion absorption emission mechanism is discussed in (1990CH14). See also (1989CH1O, 1990CH1U) and see (1989YU1A). A quark-antiquark annihilation mechanism is proposed in (1989CH21). A two-amplitude model for the DCX energy dependence is described in (1989FO02). In other recent work, the contribution of sequential charge exchange and delta-nucleon charge exchange is examined in (1993GI03). Absorption contributions near  $T_\pi = 50$  MeV are evaluated by (1992OS05). High energy DCX and isovector renormalization is calculated and compared with data in (1993OS01). See also (1992MA46) for a discussion of dibaryon effects.

10.  $^{20}\text{Ne}(\text{p}, \text{t})^{18}\text{Ne}$   $Q_m = -20.022$

Observed triton groups are displayed in Table 18.38 as are  $J^\pi$  derived from DWBA analysis of angular distributions: The  $0_3^+$  state, identified at  $E_x = 4.59$  MeV, appears to have a largely  $s_{1/2}^2$  configuration based on its large downward shift with respect to the analog state in  $^{18}\text{O}$  (1981NE09).

11.  $^{20}\text{Ne}(^3\text{He}, n\alpha)^{18}\text{Ne}$   $Q_m = -7.926$

See (1991GU05).

### $^{18}\text{Na}$

(Not observed)

$^{18}\text{Na}$  has not been observed; its atomic mass excess has been estimated to be  $25.32$  MeV (1993AU05); it is then unbound with respect to proton emission by  $1.6$  MeV: see (1978AJ03). See also (1986AN07) and (1983ANZQ).

### $^{18}\text{Mg}$ , etc.

(Not observed)

See (1986AN07) and (1983ANZQ). See also the results of calculations of  $\beta^+$ /electron capture half lives for neutron deficient nuclei in (1993HI08).

Table 18.39: Isospin triplet components ( $T = 1$ ) in  $A = 18$  nuclei <sup>a</sup>

<sup>18</sup> O		<sup>18</sup> F			<sup>18</sup> Ne		
$E_x$ (MeV)	$J^\pi$	$E_x$ (MeV)	$J^\pi; T$	$\Delta E_x$ (MeV) <sup>b</sup>	$E_x$ (MeV)	$J^\pi$	$\Delta E_x$ (MeV) <sup>c</sup>
0	0 <sup>+</sup>	1.04	0 <sup>+</sup> ; 1	–	0	0 <sup>+</sup>	–
1.98	2 <sup>+</sup>	3.06	2 <sup>+</sup> ; 1	+0.04	1.88	2 <sup>+</sup>	–0.09
3.55	4 <sup>+</sup>	4.65	4 <sup>+</sup> ; 1	+0.06	3.38	4 <sup>+</sup>	–0.18
3.63	0 <sup>+</sup>	4.75	0 <sup>+</sup> ; 1	+0.08	3.57	0 <sup>+</sup>	–0.06
3.92	2 <sup>+</sup>	4.96	2 <sup>+</sup> ; 1	+0.002	3.62	2 <sup>+</sup>	–0.30
4.46	1 <sup>–</sup>	5.60	1 <sup>–</sup> ; 0 + 1	+0.11	4.52	1 <sup>–</sup>	+0.06
		5.67	1 <sup>–</sup> ; 0 + 1	+0.18			
5.10	3 <sup>–</sup>	6.240	3 <sup>–</sup> ; 0 + 1	+0.10	5.09	(2 <sup>+</sup> , 3 <sup>–</sup> )	–0.01
		6.242	3 <sup>–</sup> ; 0 + 1	+0.10	5.15	(2 <sup>+</sup> , 3 <sup>–</sup> )	+0.05
5.25	2 <sup>+</sup>	6.28	2 <sup>+</sup> ; 1	–0.01	4.59	0 <sup>+</sup>	–0.75
		6.39	2 <sup>+</sup> ; 1	+0.09			
5.34	0 <sup>+</sup>	6.14	0 <sup>+</sup> ; 1	–0.24			
5.38	3 <sup>+</sup>	6.16	3 <sup>+</sup> ; 1	–0.26			
5.53	2 <sup>–</sup>	6.64	2 <sup>–</sup> ; 1	+0.07			
6.19	1 <sup>–</sup>	7.34	1 <sup>–</sup> ; 1	+0.10			

<sup>a</sup> As taken from Tables 18.9, 18.24 and 18.36.

<sup>b</sup> Defined as  $E_x(^{18}\text{F}) - E_x(^{18}\text{O}) - 1.04$  MeV.

<sup>c</sup> Defined as  $E_x(^{18}\text{Ne}) - E_x(^{18}\text{O})$ .

Table 18.40: ( $T = 2$ ) states in  $^{18}\text{N}$  and  $^{18}\text{O}$  <sup>a</sup>

$^{18}\text{N}$		$^{18}\text{O}$	
$E_x$ (MeV)	$J^\pi$	$E_x$ (MeV)	$J^\pi; T$
0	$1^-$ <sup>b</sup>		
0.11	$(2^-)$ <sup>b, c</sup>	16.4	$2^-; 2$
0.59	$(2^-)$ <sup>b</sup>		
0.75	$(3^-)$ <sup>b, c</sup>	17.03	$(3^-); 2$
		17.4	$1^-; (2)$
		18.7	$(4^-); 2$
		18.9	$1^+; 2$
		19.24	$(> 2); 2$
		19.4	$1^-; (2)$
		20.36	$(4^-); 2$
		21.42	$(4^-); (2)$
		22.40	$4^-; 2$
		27	$1^-; (2)$

<sup>a</sup> As taken from Tables 18.4 and 18.9.

<sup>b</sup> Coulomb-shift computations (R. Sherr, private communication) for these four levels suggest that the analogs of the  $^{18}\text{N}$   $1^-$  and  $(2^-)$  levels at  $E_x = 0$  and 0.59 MeV are the  $^{18}\text{O}$   $1^{(-)}$  and  $(3, 2)^-$  levels at  $E_x = 16.21$  and 16.95 MeV respectively.

<sup>c</sup> It is noted (A.H. Wapstra, private communication) that the combined evidence on these two levels and their analogs in  $^{18}\text{O}$  is an argument for assignments of  $2^-$  and  $(3^-)$  in both nuclei, and in  $^{18}\text{O}$  they should lie above an unobserved  $1^-; 2$  state near 16.3 MeV.

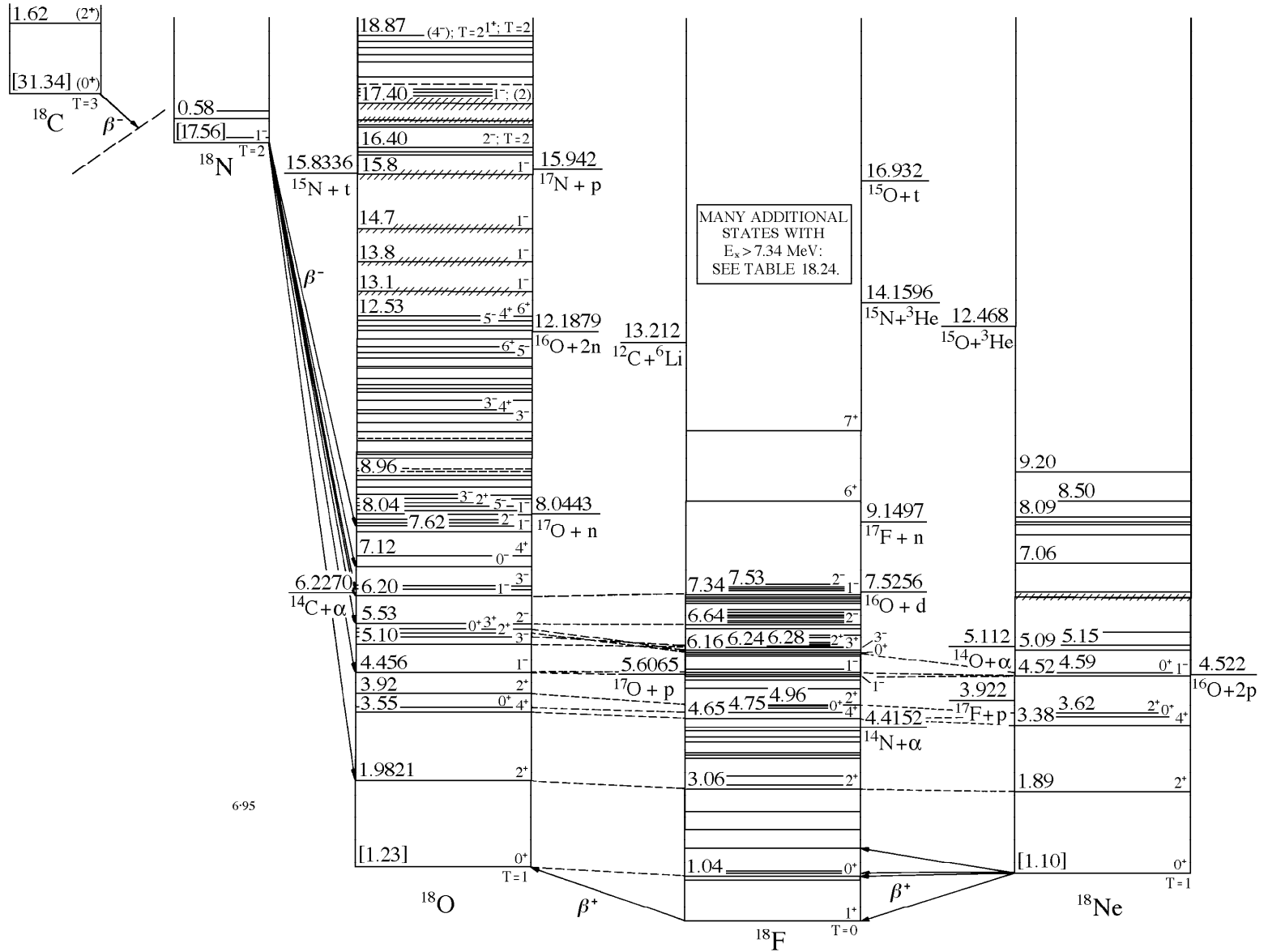

Fig. 5: Isobar diagram,  $A = 17$ . The diagrams for individual isobars have been shifted vertically to eliminate the neutron-proton mass difference and the Coulomb energy, taken as  $E_C = 0.60Z(Z - 1)/A^{1/3}$ . Energies in square brackets represent the (approximate) nuclear energy,  $E_N = M(Z, A) - ZM(\text{H}) - NM(\text{n}) - E_C$ , minus the corresponding quantity for  $^{18}\text{F}$ : here  $M$  represents the atomic mass excess in MeV. Levels which are presumed to be isospin multiplets are connected by dashed lines.

## References

(Closed 31 October 1994)

- 1962HI06 S. Hinds, H. Marchant and R. Middleton , Nucl. Phys. 38 (1962) 81
- 1972AJ02 F. Ajzenberg-Selove, Nucl. Phys. A190 (1972) 1
- 1973JO13 P.L. Jolivette, Phys. Rev. C8 (1973) 1230
- 1973OL02 J.W. Olness, E.K. Warburton and J.A. Becker, Phys. Rev. C7 (1973) 2239
- 1973RO03 C. Rolfs, A.M. Charlesworth and R.E. Azuma, Nucl. Phys. A199 (1973) 257
- 1973RO04 C. Rolfs, W.E. Kieser, R.E. Azuma and A.E. Litherland, Nucl. Phys. A199 (1973) 274
- 1973RO06 C. Rolfs, I. Berka and R.E. Azuma, Nucl. Phys. A199 (1973) 306
- 1974AJ01 F. Ajzenberg-Selove and T. Lauritsen, Nucl. Phys. A227 (1974) 1
- 1974ES02 J.L. Escudie, R. Lombard, M. Pignanelli, F. Resmini and A. Tarrats, Phys. Rev. C10 (1974) 1645; Erratum Phys. Rev. C11 (1975) 639
- 1975SO05 K.H. Souw, J.C. Adloff, D. Disdier and P. Chevallier, Phys. Rev. C11 (1975) 1899
- 1976CH24 L.C. Chen, Phys. Rev. C14 (1976) 2069
- 1976LA13 R.D. Lawson, F.J.D. Serduke and H.T. Fortune, Phys. Rev. C14 (1976) 1245
- 1978AJ03 F. Ajzenberg-Selove, Nucl. Phys. A300 (1978) 1
- 1979FE06 M.P. Fewell, A.M. Baxter, D.C. Kean, R.H. Spear and T.H. Zabel, Nucl. Phys. A321 (1979) 457
- 1979KI12 W.E. Kieser, R.E. Azuma, I. Berka, K.P. Jackson, A.B. McDonald, H.B. Mak, and W. McLatchie, Nucl. Phys. A327 (1979) 172
- 1979KI13 W.E. Kieser, R.E. Azuma and K.P. Jackson, Nucl. Phys. A331 (1979) 155
- 1979WO04 J.G. Woodworth, K.G. McNeill, J.W. Jury, R.A. Alvarez, B.L. Berman, D.D. Paul and P. Meyer, Phys. Rev. C19 (1979) 1667
- 1980MA26 H.-B. Mak, G.T. Ewan, H.C. Evans, J.D. MacArthur, W. McLatchie and R.E. Azuma, Nucl. Phys. A343 (1980) 79
- 1980NA14 F. Naulin, C. Detraz, M. Bernas, D. Guillemaud, E. Kashy, M. Langevin, F. Pougheon, P. Roussel and M. Roy-Stephan, J. Phys. Lett. 41 (1980) L79
- 1981CO13 M.E. Cobern, L.C. Bland, H.T. Fortune, G.E. Moore, S. Mordechai and R. Middleton, Phys. Rev. C23 (1981) 2387
- 1981CU07 A. Cunsolo, A. Foti, G. Imme, G. Pappalardo, G. Raciti and N. Saunier, Phys. Rev. C24 (1981) 476

- 1981GL02 C.W. Glover and K.W. Kemper, Nucl. Phys. A366 (1981) 469
- 1981LE1A F. Leccia, P. Mennrath, A. Morales, J. Morales, R. Nunez-Lagos and M. Plo, An. Fis. A77 (1981) 114
- 1981ME13 M.C. Mermaz, J. Barrette and H.E. Wegner, Phys. Rev. C24 (1981) 2148
- 1981NE09 A.V. Nero, E.G. Adelberger and F.S. Dietrich, Phys. Rev. C24 (1981) 1864
- 1982AB04 M.S. Abdel-Wahab, L. Potvin, R. Roy, P. Bricault, R. Larue, D. Pouliot, C. Rioux and R.J. Slobodrian, Can. J. Phys. 60 (1982) 1595
- 1982AH07 G. Ahrens, W. Harfst, J.R. Kass, E.V. Mason, H. Schober, G. Steffens, H. Waeffler, P. Bock and K. Grotz, Nucl. Phys. A390 (1982) 486
- 1982AN12 M.S. Antony, J. Phys. G8 (1982) 1659
- 1982AV1A Averyanoy, Golubev and Sadovi, Sov. J. Nucl. Phys. 35 (1982) 484
- 1982BA03 K. Bangert, U.E.P. Berg, G. Junghans, R. Stock and K. Wienhard, Nucl. Phys. A376 (1982) 15
- 1982BA06 G.C. Ball, T.K. Alexander, W.G. Davies, J.S. Forster and I.V. Mitchell, Nucl. Phys. A377 (1982) 268
- 1982BA40 G.C. Ball, T.K. Alexander, W.G. Davies, J.S. Forster, I.V. Mitchell, J. Keinonen and H. B. Mak, Nucl. Phys. A386 (1982) 333
- 1982BA49 Z. Basrak, R. Caplar, C. Beck, R.M. Freeman and F. Haas, Phys. Rev. C26 (1982) 1774
- 1982BE29 H.W. Becker, W.E. Kieser, C. Rolfs, H.P. Trautvetter and M. Wiescher, Z. Phys. A305 (1982) 319
- 1982CU01 A. Cunsolo, A. Foti, G. Imme, G. Pappalardo, G. Raciti and N. Saunier, Phys. Lett. B112 (1982) 121
- 1982DE30 L.C. Dennis, K.M. Abdo, A.D. Frawley and K.W. Kemper, Phys. Rev. C26 (1982) 981
- 1982FI10 L.K. Fifield, J.L. Durell, M.A.C. Hotchkis, J.R. Leigh, T.R. Ophel and D.C. Weisser, Nucl. Phys. A385 (1982) 505
- 1982FR15 R.M. Freeman, P.A. DeYoung, L.J. Satkowiak, M.A. Xapsos and J.J. Kolata, Nucl. Phys. A385 (1982) 516
- 1982GL08 C. Glashauser, R. de Swiniarski, K. Jones, S. Nanda, F.T. Baker, M. Grimm, V. Penumetcha, A. Scott, G. Adams, G. Igo et al., Phys. Lett. B116 (1982) 215
- 1982HE04 A.M. Hernandez and W.W. Daehnick, Phys. Rev. C25 (1982) 2957
- 1982HE07 B. Heusch, C. Beck, J.P. Coffin, P. Engelstein, R.M. Freeman, G. Guillaume, F. Haas and P. Wagner, Phys. Rev. C26 (1982) 542
- 1982HU06 M. Hugi, J. Lang, R. Muller, J. Sromicki, E. Ungricht, K. Bodek, L. Jarczyk, B. Kamys, A. Strzalkowski and H. Witala, Phys. Rev. C25 (1982) 2403



- 1982KO24 J.J. Kolata, E.G. Funk and J.D. Hinnefeld, *Phys. Rev. C*26 (1982) 1750
- 1982MO09 R. Moro, A. Brondi, A. D'Onofrio, V. Roca, M. Romano, F. Terrasi and B. Delaunay, *Lett. Nuovo Cim.* 33 (1982) 407
- 1982NO04 B.E. Norum, M.V. Hynes, H. Miska, W. Bertozzi, J. Kelly, S. Kowalski, F.N. Rad, C.P. Sargent, T. Sasanuma, W. Turchinets et al., *Phys. Rev. C*25 (1982) 1778
- 1982OL01 J.W. Olness, E.K. Warburton, D.E. Alburger, C.J. Lister and D.J. Millener, *Nucl. Phys.* A373 (1982) 13
- 1982PI06 E. Piasetzky, A. Altman, J. Lichtenstadt, A.I. Yavin, D. Ashery, W. Bertl, L. Felawka, H.K. Walter, F.W. Schlegel, R.J. Powers et al., *Phys. Rev. C*26 (1982) 2702
- 1982RE14 K.E. Rehm, W. Henning, J.R. Erskine and D.G. Kovar, *Phys. Rev. C*26 (1982) 1010
- 1982VE13 J. Vernotte, G. Berrier-Ronsin, J. Kalifa and R. Tamisier, *Nucl. Phys.* A390 (1982) 285
- 1983AD03 E.G. Adelberger, M.M. Hindi, C.D. Doyle, H.E. Swanson, R.D. von Lintig and W.C. Haxton, *Phys. Rev. C*27 (1983) 2833
- 1983AJ01 F. Ajzenberg-Selove, *Nucl. Phys.* A392 (1983) 1; Errata *Nucl. Phys.* A413 (1984) 168
- 1983AN05 B.D. Anderson, A. Fazely, R.J. McCarthy, P.C. Tandy, J.W. Watson, R. Madey, W. Bertozzi, T.N. Buti, J.M. Finn, J. Kelly et al., *Phys. Rev. C*27 (1983) 1387
- 1983ANZQ Y. Ando, M. Uno and M. Yamada, JAERI-M-83-025 (1983)
- 1983AR11 K.P. Artemov, V.Z. Gol'dberg, M.S. Golovkov, B.G. Novatskii, I.P. Petrov, V.P. Rudakov, Serikov and V.A. Timofeev, *Sov. J. Nucl. Phys.* 37 (1983) 805; *Yad. Fiz.* 37 (1983) 1351
- 1983AS01 D. Ashery, D.F. Geesaman, R.J. Holt, H.E. Jackson, J.R. Specht, K.E. Stephenson, R.E. Segel, P. Zupranski, H.W. Baer, J.D. Bowman et al., *Phys. Rev. Lett.* 50 (1983) 482
- 1983BE36 D. Bender, A. Richter, E. Spamer, E.J. Ansaldo, C. Rangacharyulu and W. Knupfer, *Nucl. Phys.* A406 (1983) 504
- 1983CA21 W.N. Catford, E.F. Garman, D.M. Pringle and L.K. Fifield, *Nucl. Phys.* A407 (1983) 255
- 1983CU03 A. Cunsolo, A. Foti, G. Imme, G. Pappalardo, G. Raciti and N. Saunier, *Lett. Nuovo Cim.* 37 (1983)193
- 1983DU13 G.G. Dussel, A.O. Gattone and E.E. Maqueda, *Phys. Rev. Lett.* 51 (1983) 2366
- 1983EN02 F. Entezami, J.D. Brown, K.S. Dhuga, O. Karban, J.M. Nelson and S. Roman, *Nucl. Phys.* A405 (1983) 69
- 1983ET02 M.C. Etchegoyen, D. Sinclair, A. Etchegoyen and E. Belmont Moreno, *Nucl. Phys.* A402 (1983) 87

- 1983GA02 M. Gai, M. Ruscev, A.C. Hayes, J.F. Ennis, R. Keddy, E.C. Schloemer, S.M. Sterbenz and D.A. Bromley, *Phys. Rev. Lett.* 50 (1983) 239
- 1983GR10 E.E. Gross, J.R. Beene, K.A. Erb, M.P. Fewell, D. Shapira, M.J. Rhoades-Brown, G.R. Satchler and C.E. Thorn, *Nucl. Phys.* A401 (1983) 362
- 1983GR28 E.E. Gross and M.P. Fewell, *Nucl. Phys.* A411 (1983) 329
- 1983JA09 L. Jarczyk, B. Kamys, Z. Rudy, A. Strzalkowski, H. Witala, M. Hugi, J. Lang, R. Muller, J. Sromicki and H.H. Wolter, *Phys. Rev.* C28 (1983) 700
- 1983KI13 M.M. King Yen, S.T. Hsieh and D.S. Chuu, *J. Phys.* G9 (1983) 1347
- 1983LE03 P.M. Lewis, A.K. Basak, J.D. Brown, P.V. Drumm, O. Karban, E.C. Pollacco and S. Roman, *Nucl. Phys.* A395 (1983) 204
- 1983LE08 F. Leccia, Ph. Hubert, P. Mennrath, A. Morales, J. Morales, R. Nunez-Lagos and M. Plo, *Nuovo Cim.* A74 (1983) 28
- 1983MO16 R. Moro, A. Brondi, A. D'Onofrio, V. Roca, M. Romano, F. Terrasi, B. Delaunay and H. Dumont, *Lett. Nuovo Cim.* 38 (1983) 7
- 1983OS07 A. Osman and S.S. Abdel-Aziz, *Acta Phys. Hung.* 54 (1983) 9
- 1983PU01 G.D. Putt, L.K. Fifield, M.A.C. Hotchkis, T.R. Ophel and D.C. Weisser, *Nucl. Phys.* A399 (1983) 190
- 1983PUZZ B. Pugh, W. Bertozzi, T.N. Buti, J.M. Finn, C. Hyde, J.J. Kelly, M.A. Kovash, B. Murdock, B.D. Anderson, A.R. Baldwin, A. Fazely, C. Lebo, R. Madey, J.W. Watson and C.C. Foster, *Bull. Amer. Phys. Soc.* 28 (1983) 690
- 1983RU09 K. Rusek, Z. Moroz, R. Caplar, P. Egelhof, K.-H. Mobius, E. Steffens, I. Koenig, A. Weller and D. Fick, *Nucl. Phys.* A407 (1983) 208
- 1983SN03 K.A. Snover, E.G. Adelberger, P.G. Ikossi and B.A. Brown, *Phys. Rev.* C27 (1983) 1837
- 1983WA05 C.E. Waltham, S.H. Chew, J. Lowe, J.M. Nelson and A.R. Barnett, *Nucl. Phys.* A395 (1983) 119
- 1984AL20 A. Altman, D. Ashery, E. Piassetzky, J. Lichtenstadt, A.I. Yavin, W. Bertl, L. Felawka, H.K. Walter, R.J. Powers, R.G. Winter et al., *Phys. Lett.* B144 (1984) 337
- 1984AS05 D. Ashery, D.F. Geesaman, R.J. Holt, H.E. Jackson, J.R. Specht, K.E. Stephenson, R.E. Segel, P. Zupranski, H.W. Baer, J.D. Bowman et al., *Phys. Rev.* C30 (1984) 946
- 1984BA24 F.C. Barker, *Aust J. Phys.* 37 (1984) 17
- 1984BH01 R.K. Bhowmik, W.D.M. Rae and B.R. Fulton, *Phys. Lett.* B136 (1984) 149
- 1984BUZX B.L. Burks, D.J. Horen, R.L. Auble, F.E. Bertrand, J.L. Blankenship, J.L.C. Ford, Jr., E.E. Gross, D.C. Hensley, R.O. Sayer, D. Shapira et al., *Bull. Amer. Phys. Soc.* 29 (1984) 1026, AB6

- 1984CO05 J. Cook, L.C. Dennis, K.W. Kemper, T.R. Ophel, A.F. Zeller, C.F. Maguire and Z. Kui, Nucl. Phys. A415 (1984) 114
- 1984DE38 D.M. De Castro Rizzo, E. Bozek, S. Cavallaro, B. Delaunay, J. Delaunay, H. Dumont, M.G. Saint-Laurent and F. Terrasi, Nucl. Phys. A427 (1984) 151
- 1984DE53 P. De Bievre, M. Gallet, N.E. Holden and I.L. Barnes, J. Phys. Chem. Ref. Data 13 (1984) 809
- 1984FR14 R. Frick, H. Clement, G. Graw, P. Schiemenz, N. Seichert and Sun Tsu-Hsun, Z. Phys. A319 (1984) 133
- 1984GI10 R. Gilman, H.T. Fortune, L.C. Bland, R.R. Kiziah, C.F. Moore, P.A. Seidl, C.L. Morris and W.B. Cottingham, Phys. Rev. C30 (1984) 962
- 1984MU27 J.A. Musser and J.D. Stevenson, Phys. Rev. Lett. 53 (1984) 847
- 1984NE1A Nemets, Rudchik and Chuvilski, in Alma Ata 84 (1984) 334
- 1984OE02 W. Oelert, G. Palla, B. Rubio, M.G. Betigeri, C. Mayer-Boricke, P. Turek and H.T. Fortune, Phys. Rev. C30 (1984) 1378
- 1984RA07 W.D.M. Rae and R.K. Bhowmik, Nucl. Phys. A420 (1984) 320
- 1984RA17 W.D.M. Rae and R.K. Bhowmik, Nucl. Phys. A427 (1984) 142
- 1984SA28 V.S. Sadkovsky, G.A. Feofilov, A.E. Denisov, R.P. Kolalis and L. Peres Tamaio, Izv. Akad. Nauk SSSR Ser. Fiz. 48 (1984) 995
- 1984SE1A Seestrom-Morris et al., Tenth Int. Conf. on Particles and Nuclei, Heidelberg, 30 July-3 Aug. 1984 (Organizing Committee, 1984) F1
- 1984TA1A Tacik et al., Tenth Int. Conf. on Particles and Nuclei, Heidelberg, 30 July-3 Aug. 1984 (Organizing Committee, 1984) F13
- 1985AJ01 F. Ajzenberg-Selove, Nucl. Phys. A433 (1985) 1; Erratum Nucl. Phys. A449 (1986) 155
- 1985AL15 A. Altman, R.R. Johnson, U. Wienands, N. Hessey, B.M. Barnett, B.M. Forster, N. Grion, D. Mills, F.M. Rozon, G.R. Smith et al., Phys. Rev. Lett. 55 (1985) 1273
- 1985AN17 M.S. Antony, J. Britz, J.B. Bueb and V.B. Ndocko-Ndongue, Nuovo Cim. A88 (1985) 265
- 1985BA1A J.M. BANG, F.G. Gareev, W.T. Pinkston and J.S. Vaagen, Phys. Rep. 125 (1985) 253
- 1985BA27 B.M. Barnett, W. Gyles, R.R. Johnson, R. Tacik, K.L. Erdman, H.W. Roser, D.R. Gill, E.W. Blackmore, S. Martin, C.A. Wiedner et al., Phys. Lett. B156 (1985) 172
- 1985BE40 C. Beck, F. Haas, R.M. Freeman, B. Heusch, J.P. Coffin, G. Guillaume, F. Rami and P. Wagner, Nucl. Phys. A442 (1985) 320
- 1985BI03 M. Bini, T.F. Fazzini, G. Poggi and N. Taccetti, Phys. Rev. Lett. 55 (1985) 795
- 1985CA01 N. Carlin Filho, M.M. Coimbra, J.C. Acquadro, R. Liguori Neto, E.M. Szanto, E. Farrelly-Pessoa and A. Szanto de Toledo, Phys. Rev. C31 (1993) 152

- 1985CA41 G.R. Caughlan, W. A. Fowler, M.J. Harris and B.A. Zimmerman, *At. Data Nucl. Data Tables* 32 (1985) 197
- 1985DE60 Detraz, J. *Phys. Soc. Jpn., Suppl.* 54 (1985) 27
- 1985DY05 P. Dyer, D. Bodansky, D.D. Leach, E.B. Norman and A.G. Seamster, *Phys. Rev. C* 32 (1985) 1873
- 1985EV03 H.C. Evans, G.T. Ewan, S.-P. Kwan, J.R. Leslie, J.D. MacArthur, H.-B. Mak, W. McLatchie, S.A. Page, P. Skensved, S.-S. Wang et al., *Phys. Rev. Lett.* 55 (1985) 791
- 1985FO11 H.T. Fortune, L.C. Bland and W.D.M. Rae, *J. Phys.* G11 (1985) 1175
- 1985GR1B C. Grama, N. Grama and Gh. Voiculescu, *Rev. Roum. Phys.* 30 (1985) 23
- 1985HA11 J.S. Hanspal, R.J. Griffiths and N.M. Clarke, *Phys. Rev. C* 31 (1985) 1138
- 1985JOZZ P.L. Jolivette, M.J. Honkanen, M. Young and E. Moser, *Bull. Amer. Phys. Soc.* 30 (1985) 1248, AC7
- 1985KE03 E. Kerkhove, R. van de Vyver, H. Ferdinande, D. Ryckbosch, P. van Otten, P. Berkvens and E. van Camp, *Phys. Rev. C* 32 (1985) 368
- 1985KE1C J. Keinonen, *AIP Conf. Proc.* 125 (1985) 557
- 1985KO04 D. Konnerth, W. Trombik, K.G. Bernhardt, K.A. Eberhard, R. Singh, A. Strzalkowski and W. Trautmann, *Nucl. Phys.* A436 (1985) 538
- 1985LA03 M. Langevin, E. Quiniou, M. Bernas, J. Galin, J.C. Jacmart, F. Naulin, F. Pougheon, R. Anne, C. Detraz, D. Guerreau, D. Guillemaud-Mueller and A.C. Mueller, *Phys. Lett.* B150 (1985) 71
- 1985PO10 N.A.F.M. Poppelier, L.D. Wood and P.W.M. Glaudemans, *Phys. Lett.* B157 (1985) 120
- 1985SE08 P.A. Seidl, C.F. Moore, S. Mordechai, R. Gilman, K.S. Dhuga, H.T. Fortune, J.D. Zumbro, C.L. Morris, J.A. Faucett and G.R. Bursleson, *Phys. Lett.* B154 (1985) 255
- 1985TH03 J. Thomas, Y.T. Chen, S. Hinds, K. Langanke, D. Meredith, M. Olson and C.A. Barnes, *Phys. Rev. C* 31 (1985) 1980
- 1985VO12 K.F. von Reden, W.W. Daehnick, S.A. Dytman, R.D. Rosa, J.D. Brown, C.C. Foster, W.W. Jacobs and J.R. Comfort, *Phys. Rev. C* 32 (1985) 1465
- 1985WA02 A.H. Wapstra and G. Audi, *Nucl. Phys.* A432 (1985) 1
- 1985WU03 J.Q. Wu, G. Bertsch and A.B. Balantekin, *Phys. Rev. C* 32 (1985) 1432
- 1986ADZT E.G. Adelberger, in *AIP Conf. Proc.* 150 (1986) 1177
- 1986AJ01 F. Ajzenberg-Selove, *Nucl. Phys.* A449 (1986) 1
- 1986AJ04 F. Ajzenberg-Selove, *Nucl. Phys.* A460 (1986) 1
- 1986AL22 A. Altman, D. Ashery, E. Piasezky, J. Lichtenstadt, A.I. Yavin, W. Bertl, L. Felawka, H.K. Walter, R.J. Powers, R.G. Winter et al., *Phys. Rev. C* 34 (1986) 1757

- 1986AN07 M.S. Antony, J. Britz and A. Pape, *At. Data Nucl. Data Tables* 34 (1986) 279
- 1986AN1E B.D. Anerson, J.W. Watson and R. Madey, *AIP Conf. Proc.* 142 (1986) 155
- 1986BR04 G. Bruge, A. Chaumeaux, P. Birien, D.M. Drake, D. Garreta, S. Janouin, D. Legrand, M.C. Lemaire, B. Mayer, J. Pain et al., *Phys. Lett. B*169 (1986) 14
- 1986CU02 B. Cujec, B. Dasmahapatra, Q. Haider, F. Lahlou and R.A. Dayras, *Nucl. Phys. A*453 (1986) 505
- 1986DR03 P.V. Drumm, O. Karban, A.K. Basak, P.M. Lewis, S. Roman and G.C. Morrison, *Nucl. Phys. A*448 (1986) 93
- 1986GA13 E.N. Gazis, C.T. Papadopoulos, R. Vlastou and A.C. Xenoulis, *Phys. Rev. C*34 (1986) 872
- 1986GL02 K. Glasner, L. Ricken and E. Kuhlmann, *Nucl. Phys. A*452 (1986) 150
- 1986HA1I W.C. Haxton, *AIP Conf. Proc.* 150 (1986) 738
- 1986HA1J A.C. Hayes, D.A. Bromley and D.J. Millener, unpublished manuscript
- 1986IC01 H. Ichihara and H. Yoshida, *Nucl. Phys. A*448 (1993) 546
- 1986KA1C M. Kamimura, Y. Sakuragi, M. Yahiro and M. Tanifuji, *J. Phys. Soc. Jpn. Suppl.* 55 (1986) 205
- 1986KA36 Y. Kadota, K. Ogino, K. Oboiri, Y. Taniguchi, T. Tanabe, M. Yasue and J. Schimizu, *Nucl. Phys. A*458 (1986) 523
- 1986KE05 J. Kelly, W. Bertozzi, T.N. Buti, J.M. Finn, F.W. Hersman, M.V. Hynes, C. Hyde-Wright, B.E. Norum, A.D. Bacher, G.T. Emery et al., *Phys. Lett. B*169 (1986) 157
- 1986KE1C J.J. Kelly, *AIP Conf. Proc.* 142 (1986) 27
- 1986KO10 P.E. Koehler, H.D. Knox, D.A. Resler, R.O. Lane and G.F. Auchampaugh, *Nucl. Phys. A*453 (1986) 429
- 1986KO1E H. Koch, *AIP Conf. Proc.* 150 (1986) 490
- 1986KO22 Th. Kohler, P. Blum, G. Buche, A.D. Hancock, H. Koch, A. Kreissl, H. Poth, U. Raich, D. Rohmann, G. Backenstoss et al., *Phys. Lett. B*176 (1986) 327
- 1986KR04 A. Krasznahorkay, T. Kibedi and Zs. Dombradi, *Z. Phys. A*323 (1986) 125
- 1986LE13 M.-C. Lemaire, P. Birien, G. Bruge, D.M. Drake, D. Garreta, S. Janouin, D. Legrand, B. Mayer, J. Pain, J.C. Peng et al., *Nucl. Phys. A*456 (1986) 557
- 1986MA13 J.F. Mateja, A.D. Frawley, R.A. Parker and K. Sartor, *Phys. Rev. C*33 (1986) 1307
- 1986MA32 N. Matsuoka, H. Sakai, T. Saito, K. Hosono, M. Kondo, H. Ito, K. Hatanaka, T. Ichihara, A. Okihana, K. Imai et al., *Nucl. Phys. A*455 (1986) 413
- 1986MA48 D.M. Manley, B.L. Berman, W. Bertozzi, J.M. Finn, F.W. Hersman, C.E. Hyde-Wright, M.V. Hynes, J.J. Kelly, M.A. Kovash, S. Kowalski et al., *Phys. Rev. C*34 (1986) 1214

- 1986PO13 F. Pougheon, D. Guillemaud-Mueller, E. Quiniou, M.G. Saint Laurent, R. Anne, D. Bazin, M. Bernas, D. Guerreau, J.C. Jacmart, S.D. Hoath et al., *Europhys. Lett.* 2 (1986) 505
- 1986SM01 M.J. Smithson, D.L. Watson and H.T. Fortune, *Phys. Rev.* C33 (1986) 509
- 1986STZY S.M. Sterbenz, M. Gai, J.F. Shriner, Jr., P.D. Cottle, D.A. Bromley, M. Morando and R.A. Ricci, *Bull. Amer. Phys. Soc.* 31 (1986) 839
- 1986TA1B Tanaka et al., *J. Phys. Soc. Jpn. Suppl.* 55 (1986) 764
- 1986TH01 J. Thomas, Y.T. Chen, S. Hinds, D. Meredith and M. Olson, *Phys. Rev.* C33 (1986) 1679
- 1986YA12 T. Yamaya, J.I. Hirota, K. Takimoto, S. Shimoura, A. Sakaguchi, S. Kubono, M. Sugitani, S. Kato, T. Suehiro and M. Fukada, *Phys. Rev.* C34 (1986) 2369
- 1987AB03 H. Abele, H.J. Hauser, A. Korber, W. Leitner, R. Neu, H. Plappert, T. Rohwer, G. Staudt, M. Strasser, S. Welte et al., *Z. Phys.* A326 (1987) 373
- 1987AD04 S. Adachi and H.V. von Geramb, *Nucl. Phys.* A470 (1987) 461
- 1987AJ02 F. Ajzenberg-Selove, *Nucl. Phys.* A475 (1987) 1
- 1987AN1A R. Anne, D. Bazin, A.C. Mueller, J.C. Jacmart and M. Langevin, *Nucl. Instrum. Meth. Phys. Res.* A257 (1987) 215
- 1987AS05 H.J. Assenbaum, K. Langanke and C. Rolfs, *Z. Phys.* A327 (1987) 461
- 1987BE1H B. Bézard, J.P. Baluteau, A. Marten and N. Coron, *ICARUS* 72 (1987) 623
- 1987BE1I M. Bedjidian, D. Contardo, E. Descroix, S. Gardien, J.Y. Grossiord, A. Guichard, M. Gusakow, R. Haroutunian, M. Jacquin, J.R. Pizzi et al., *Z. Phys.* A327 (1987) 337
- 1987BL18 R. Blumel and K. Dietrich, *Nucl. Phys.* A471 (1987) 453
- 1987BO16 N. Bordes, G. Blondiaux, C.J. Maggiore, M. Valladon, J.L. Debrun, R. Coquille and M. Gauneau, *Nucl. Instrum. Methods Phys. Res.* B24-25 (1987) 722
- 1987BU07 M. Bürgel, H. Fuchs, H. Homeyer, G. Ingold, U. Jahnke and G. Thoma, *Phys. Rev.* C36 (1987) 90
- 1987BU12 L. Buchmann, J.M. D'Auria, J.D. King, G. Mackenzie, H. Schneider, R.B. Moore and C. Rolfs, *Nucl. Instrum. Meth. Phys. Res.* B26 (1987) 151
- 1987BU27 N.T. Burtebaev, A.D. Duisebaev, V.S. Sadkovskii and G.A. Feofilov, *Izv. Akad. Nauk SSSR Ser. Fiz.* 51 (1987) 615; *Bull. Acad. Sci. USSR Phys. Ser.* 51 (1987) 191
- 1987CH14 S. Chakravarti, D. Dehnhard, M.A. Franey, S.J. Seestrom-Morris, D.B. Holtkamp, C.L. Blilie, A.C. Hayes, C.L. Morris and D.J. Millener, *Phys. Rev.* C35 (1987) 2197
- 1987CH1J W.H. Chung, *Singapore J. Phys.* 4 (1987) 15; *Phys. Abs.* 67730 (1987)
- 1987CO07 J. Cook, *Nucl. Phys.* A465 (1987) 207
- 1987CO31 P.D. Cottle and K.W. Kemper, *Phys. Rev.* C36 (1987) 2034



- 1987DJ01 C. Djalali, G.M. Crawley, B.A. Brown, V. Rotberg, G. Caskey, A. Galonsky, N. Marty, M. Morlet and A. Willis, Phys. Rev. C35 (1987) 1201
- 1987ER05 T. Erikson, K.F. Quader, G.E. Brown and H.T. Fortune, Nucl. Phys. A465 (1987) 123
- 1987FA1C A.J. Fahey, J.N. Goswami, K.D. McKeegan and E.K. Zinner, Astrophys. J. 323 (1987) L91
- 1987FE04 M.A.G. Fernandes, F.E. Bertrand, R.L. Auble, R.O. Sayer, B.L. Burks, D.J. Horen, E.E. Gross, J.L. Blankenship, D. Shapira and M. Beckerman, Phys. Rev. C36 (1987) 108
- 1987GA15 M. Gai, R. Keddy, D.A. Bromley, J.W. Olness and E.K. Warburton, Phys. Rev. C36 (1987) 1256
- 1987GAZW M. Gai, Z. Zhao and B.A. Brown, Bull. Amer. Phys. Soc. 32 (1987) 1579, EC8
- 1987GI1C W.R. Gibbs and B.F. Gibson, Ann. Rev. Nucl. Part. Sci. 37 (1987) 411
- 1987GO1V C.D. Goodman, Can. J. Phys. 65 (1987) 549
- 1987GOZX J. Gorres, M. Wiescher, U. Giesen, H.W. Becker, C. Rolfs and H.P. Trautvetter, Bull. Amer. Phys. Soc. 32 (1987) 1062, EG9
- 1987GR16 J.M. Greben, Phys. Lett. B192 (1987) 287
- 1987GR1I A.M. Green and J.A. Niskanen, Prog. Part. Nucl. Phys. 18 (1987) 93
- 1987GR20 A.M. Green and S. Wycech, Nucl. Phys. A467 (1987) 744
- 1987GU1D Gulkarov and Mansurov, 37th Meeting on Nuclear Spectroscopy and the Structure of the At. Nucl., Jurmala, USSR, 14-17 April 1987 (Nauka, 1987) 516
- 1987HA1J P. Haapakoski, Mod. Phys. Lett. A2 (1987) 359
- 1987HE1H T.K. Hemmick, D. Elmore, P.W. Kubik, S.L. Olsen, T. Gentile, D. Nitz, D. Ciampa, H. Kagan, P. Haas, P.F. Smith et al., Nucl. Instrum. Meth. Phys. Res. B29 (1987) 389
- 1987HI05 D. Hilscher, H. Rossner, A. Gamp, U. Jahnke, B. Cheynis, B. Chambon, D. Drain, C. Pastor, A. Giorni, C. Morand et al., Phys. Rev. C36 (1987) 208
- 1987HI1B R.D. Hichwa, E.A. Hugel, J.J. Moskwa and R.R. Raylman, Nucl. Instrum. Meth. Phys. Res. B24-25 (1987) 932
- 1987HO18 D.J. Horen, M.A.G. Fernandes, G.R. Satchler, B.L. Burks, R.L. Auble, F.E. Bertrand, E.E. Gross, D.C. Hensley, R.O. Sayer and D. Shapira, Z. Phys. A328 (1987) 189
- 1987JU07 J.W. Jury, P.C.-K. Kuo, K.G. McNeill, C.K. Ross, H.R. Weller and S. Raman, Phys. Rev. C36 (1987) 1243
- 1987KA39 T. Karapiperis and M. Kobayashi, Ann. Phys. 177 (1987) 1
- 1987LE1B F. Lenz, Prog. Theor. Phys. Suppl. 91 (1987) 27
- 1987LE1L B.-K. Lee, M.-H. Cha and S.-K. Nam, New. Phys. (S. Korea) 27 (1987) 405
- 1987LI1F X.-Y. Li, S.-H. Yao and Q.-Y. Zhang, High Energy Phys. Nucl. Phys. 11 (1987) 397

- 1987MA22 E. Maglione, G. Poullarolo, A. Vitturi, R.A. Broglia and A. Winther, Phys. Lett. B191 (1987) 237
- 1987MA40 D.M. Manley and J.J. Kelly, Phys. Rev. C36 (1987) 1646
- 1987MC1A K.D. McKeegan, Science 237 (1987) 1468
- 1987ME12 O. Meirav, E. Friedman, A. Altmann, M. Hanna, R.R. Johnson and D.R. Gill, Phys. Rev. C36 (1987) 1066
- 1987MI25 D.J. Millener, Phys. Rev. C36 (1987) 1643
- 1987MIZY A. Middleton, J.D. Brown, L. Herold, K.E. Luther, M.L. Pitt, D. Barker, H.S. Camarda and S. Aziz, Bull. Amer. Phys. Soc. 32 (1987) 1578
- 1987MO27 M.H. Cha, J.Y. Park and W. Scheid, Phys. Rev. C36 (1987) 2341
- 1987MU16 H. Muther, R. Machleidt and R. Brockmann, Phys. Lett. B198 (1987) 45
- 1987NG01 Nguyen Van Sen, Ye Yanlin, J. Arvieux, G. Gaillard, B. Bonin, A. Boudard, G. Bruge, J.C. Lugol, T. Hasegawa, F. Soga et al., Nucl. Phys. A464 (1987) 717
- 1987PA07 S.A. Page, H.C. Evans, G.T. Ewan, S.-P. Kwan, J.R. Leslie, J.D. MacArthur, W. McLatchie, P. Skensved, S.-S. Wang, H.-B. Mak et al., Phys. Rev. C35 (1987) 1119
- 1987PA12 S.J. Padalino, K. Sartor, L.C. Dennis and K.W. Kemper, Phys. Rev. C35 (1987) 1692
- 1987PA1H B. Parker, K. Seth and R. Soundranayagam, Panic (1987) 356
- 1987PO11 V. Ponisch and S.E. Koonin, Phys. Rev. C36 (1987) 633
- 1987RA01 S. Raman, C.H. Malarkey, W.T. Milner, C.W. Nestor, Jr. and P.H. Stelson, At. Data Nucl. Data Tables 36 (1987) 1
- 1987RA1D R. Ramaty and R.J. Murphy, Space Sci. Rev. 45 (1987) 213
- 1987RA28 M. Rajasekaran, N. Arunachalam and V. Devanathan, Phys. Rev. C36 (1987) 1860
- 1987RA36 M. Rahman, H.M. Sen Gupta, Md.A. Rahman and A.B. Siddique, Nuovo Cim. A98 (1987) 513
- 1987RI03 J. Richert and P. Wagner, Nucl. Phys. A466 (1987) 132
- 1987SA25 M.G. Saint-Laurent, Nucl. Instrum. Meth. Phys. Res. B26 (1987) 273
- 1987SC11 L. Schmieder, D. Hilscher, H. Rossner, U. Jahnke, M. Lehmann, K. Ziegler and H.-H. Knitter, Nucl. Instrum. Meth. Phys. Res. A256 (1987) 457
- 1987SC34 A. Scalia, Nuovo Cim. A98 (1987) 589
- 1987SE1D J.P.F. Sellschop, Nucl. Instrum. Meth. Phys. Res. B29 (1987) 439
- 1987SH10 H.-Q. Song, Z. Wang, Y. Cai and W. Huang, Chin. Phys. 7 (1987) 471
- 1987SN01 K. Sneppen, Nucl. Phys. A470 (1987) 213
- 1987SO1E C.P. Sonett, G.E. Morfill and J.R. Jokipii, Nature 330 (1987) 458



- 1987TA07 Y. Tagishi, Y. Aoki, M. Kurokawa, T. Murayama, T. Sakai, M. Takei, M. Tomizawa and K. Yagi, *Phys. Rev. C*35 (1987) 1153
- 1987TA13 T.N. Taddeucci, C.A. Goulding, T.A. Carey, R.C. Byrd, C.D. Goodman, C. Gaarde, J. Larsen, D. Horen, J. Rapaport and E. Sugarbaker, *Nucl. Phys. A*469 (1993) 125
- 1987TA21 M. Tanaka, T. Yamagata, S. Nakayama, M. Inoue, Y. Sakuragi, M. Kamimura, K. Goto, K. Katori, M. Yanagi and H. Ogata, *Phys. Rev. C*36 (1987) 2146
- 1987VA19 S.P. Van Verst, K.W. Kemper and J.A. Carr, *Phys. Rev. C*36 (1987) 628
- 1987VA1I Valiev et al., in *Yurmala* (1987) 346
- 1987VA28 G.S. Valiev, I.R. Gulamov, Yu.I. Denisov, T. Iskhakov, A.M. Mukhamedzhanov, G.K. Ni, E.A. Romanovskii, V.A. Stepanenko and R.Ya. Yarmukhamedov, *Izv. Akad. Nauk. SSSR Ser. Fiz.* 51 (1987) 964; *Bull. Acad. Sci. USSR, Phys. Ser.* 51 (1987) 124
- 1987VD1A A.I. Vdovin, A.V. Golovin and I.I. Loschakov, *Sov. J. Part. Nucl.* 18 (1987) 573
- 1987VO1B T. von Egidy, *Nature* 328 (1987) 773
- 1987WA1F P.G. Wannier and R. Sahai, *Astrophys. J.* 319 (1987) 367
- 1987WI11 M. Wiescher, V. Harms, J. Gorres, F.-K. Theilemann and L.J. Rybarczyk, *Astrophys. J.* 316 (1987) 162
- 1987YA1E A.I. Yavin, *Can. J. Phys.* 65 (1987) 647
- 1987ZH2V Z. Zhao, M. Gai, B.J. Lund, S.M. Rugari, D. Mikolas, B.A. Brown, J.A. Nolen, Jr. and M. Samuel, *Bull. Amer. Phys. Soc.* 32 (1987) 1579, EC7
- 1987ZU1A H.-C. zur Loye, K.J. Leary, S.W. Keller, W.K. Ham, T.A. Faltens, J.N. Micheals and A.M. Stacy, *Science* 238 (1987) 1558
- 1988AP1A J.H. Applegate, *Phys. Rep.* 163 (1988) 141
- 1988BA82 H. Bando, *Nucl. Phys. A*478 (1988) 697C
- 1988BE1B J. Beer, U. Siegenthaler, G. Bonani, R.C. Finkel, H. Oeschger, M. Suter and W. Wölfli, *Nature* 331 (1988) 675
- 1988BE1T B.L. Berman, *Energy in Physics, War, and Peace, A Festschrift Celebrating E. Teller's 80th Birthday*, Ed. Hans Mark and Lowell Wood (Kluwer Academic Publ., Norwell, MA 1988) 49
- 1988BE1W M. Beckerman, *Rep. Prog. Phys.* 51 (1988) 1047
- 1988BE56 A.V. Belozarov, K.C. Borcea, J. Wincour, M. Lewitowicz, N.H. Chau, Yu.E. Penionzhkevich, N.K. Skobelev and A. Chasha, *Izv. Akad. Nauk SSSR* 52 (1988) 2171; *Bull. Acad. Sci. USSR, Phys. Ser.* 52 (1988) 90
- 1988BI07 M. Bini, T.F. Fazzini, G. Poggi and N. Taccetti, *Phys. Rev. C*38 (1988) 1195
- 1988BL11 R. Blendowske and H. Walliser, *Phys. Rev. Lett.* 61 (1988) 1930

- 1988BR11 B.A. Brown, W.A. Richter, R.E. Julies and B.H. Wildenthal, *Ann. Phys.* 182 (1988) 191
- 1988BR1P B.A. Brown and B.H. Wildenthal, *Ann. Rev. Nucl. Part. Soc.* 38 (1988) 29
- 1988BRZY J.D. Brown, A. Middleton and S.M. Aziz, *Bull. Amer. Phys. Soc.* 33 (1988) 1022
- 1988BU01 L. Buchman, J.M. D'auria and P. McCorquodale, *Astrophys. J.* 324 (1988) 953
- 1988BU15 B.L. Burks, M.A.G. Fernandes, G.R. Satchler, D.J. Horen, F.E. Bertrand, J.L. Blankenship, J.L.C. Ford, Jr., E.E. Gross, D.C. Hensley, R.O. Sayer et al., *Phys. Rev. C* 38 (1988) 1680
- 1988CA26 G.R. Caughlan and W.A. Fowler, *At. Data Nucl. Data Tables* 40 (1988) 283
- 1988CR1B Crawley et al., IPNO-ORE 88.21 (1988)
- 1988DE31 R. de Swiniarski and D.L. Pham, *Nuovo Cim. A* 99 (1988) 117
- 1988DE37 P. Descouvemont, *Phys. Rev. C* 38 (1988) 2397
- 1988DI02 S.S. Dietrich and B.L. Berman, *At. Data Nucl. Data Tables* 38 (1988) 199
- 1988ET01 M.C. Etchegoyen, A. Etchegoyen, B.H. Wildenthal, B.A. Brown and J. Keinonen, *Phys. Rev. C* 38 (1988) 1382
- 1988FA1A G. Faure, J. Hoefs, L.M. Jones, J.B. Curtis and D.E. Pride, *Nature* 332 (1988) 352
- 1988FI01 J. Fiase, A. Hamoudi, J.M. Irvine and F. Yazici, *J. Phys. G* 14 (1988) 27
- 1988FI1C H.J. Fischbeck, *Bull. Amer. Phys. Soc.* 33 (1988) 1691
- 1988FU02 C. Funck and K. Langanke, *Nucl. Phys. A* 480 (1988) 188
- 1988GOZB S.A. Goncharov, E.A. Romanovsky and N.K. Timofeyuk, in *Baku* (1988) 349
- 1988GU03 I.S. Gulkarov, M.M. Mansurov and A.A. Khomich, *Sov. J. Nucl. Phys.* 47 (1988) 25
- 1988GU12 I.S. Gul'karov, *Fiz. Elem. Chastis At. Yadra* 19 (1988) 345; *Sov. J. Part. Nucl.* 19 (1988) 149
- 1988GU1B Gulkarov, 38th Meeting on Nucl. Spectroscopy and the Structure of the At. Nucl., Baku, USSR, 12-14 April 1988 (Nauka, 1988) 169
- 1988GUZT D. Guillemaud-Mueller, R. Anne, D. Bazin, C. Detraz, J. Galin, D. Guerreau, A.C. Mueller, E. Roeckl, M.G. Saint-Laurent, M. Bernas et al., *AIP Conf. Proc.* 164 (1988) 757
- 1988HA22 W.C. Haxton, *Phys. Rev. C* 37 (1988) 2660
- 1988HAZZ A.C. Hayes, P.J. Ellis and D.J. Millener, *Bull. Amer. Phys. Soc.* 33 (1988) 929
- 1988HE1C E.M. Henley, *Interactions and Structures in Nuclei*, Proc. in Honor of D.H. Wilkinson, Sussex, 9/87, A. Hilger Publ. (1988) 151
- 1988HE1E E.M. Henley, *Prog. Part. Nucl. Phys.* 20 (1988) 387
- 1988HI05 M. Hino, K. Muto and T. Oda, *Phys. Rev. C* 37 (1988) 1328

- 1988HI1F R.D. Hichwa, Bull. Amer. Phys. Soc. 33 (1988) 1747
- 1988HI1G D.G. Hinks, D.R. Richards, B. Dabrowski, D.T. Marx and A.W. Mitchell, Nature 335 (1988) 419
- 1988HU1E R. Hutchison, C.M.O. Alexander and D.J. Barber, Phil. Trans. Roy. Soc. London A325 (1988) 445
- 1988IS02 Y. Iseri, H. Kameyama, M. Kamimura, M. Yahiro and M. Tanifuji, Nucl. Phys. A490 (1988) 383
- 1988KA1U N. Kaiser and U.-G. Meissner, Nucl. Phys. A489 (1988) 671
- 1988KA39 Sh.S. Kayumov, A.M. Mukhamedzhanov and R. Yarmukhamedov, Sov. J. Nucl. Phys. 48 (1988) 268
- 1988KE01 J.J. Kelly, Phys. Rev. C37 (1988) 520
- 1988KH06 H.A. Khan, J. Phys. G14 (1988) 701
- 1988KR11 L. Kraus, A. Boucenna, I. Linck, B. Lott, R. Rebmeister, N. Schulz, J.C. Sens, M.C. Mermaz, B. Berthier, R. Lucas et al., Phys. Rev. C37 (1988) 2529
- 1988KU17 R. Kuchta, Phys. Rev. C38 (1988) 1460
- 1988LI1O Y. LI, High Energy Phys. Nucl. Phys.12 (1988) 501; Phys. Abs. 5798
- 1988MA1Q L. Majling, J. Zofka, T. Sakuda and H. Bando, Prog. Theor. Phys. 79 (1988) 561
- 1988MA1U R.A. Malaney and W.A. Fowler, Astrophys. J. 333 (1988) 14
- 1988MA53 G. Mairle, K.T. Knopfle and M. Seeger, Nucl. Phys. A490 (1988) 371
- 1988MCZT V. McLane, C.L. Dunford and P.F. Rose, Neutron Cross Sections, Vol. 2 (Academic Press, New York, 1988)
- 1988ME10 M.C. Mermaz, Rev. Roum. Phys. 33 (1988) 739
- 1988MI1B A.C. Mix and N.G. Piasias, Nature 331 (1988) 249
- 1988MI1G D. Mikolas, B.A. Brown, W. Benenson, Y. Chen, M.S. Curtin, L.H. Harwood, E. Kashy, J.A. Nolen, Jr., M. Samuel, B. Sherrill et al., AIP Conf. Proc. 164 (1988) 708
- 1988MI1J D.J. Millener, AIP Conf. Proc. 163 (1988) 402
- 1988MU08 A.C. Mueller, D. Bazin, W.D. Schmidt-Ott, R. Anne, D. Guerreau, D. Guillemaud-Mueller, M.G. Saint-Laurent, V. Borrel, J.D. Jacmart, F. Pougheon et al., Z. Phys. A330 (1988) 63
- 1988NA02 A. Nadasen, M. McMaster, G. Gunderson, A. Judd, S. Villanueva, P. Schwandt, J.S. Winfield, J. van der Plicht, R.E. Warner, F.D. Becchetti et al., Phys. Rev. C37 (1988) 132
- 1988NW1A S.N. Nwosu, D.E. Menzie and H.J. Fischbeck, Bull. Amer. Phys. Soc. 33 (1988) 1735
- 1988POZS N.A.F.M. Poppelier, J.H. de Vries, A.A. Wolters and P.W.M. Glaudemans, in AIP Conf. Proc. 164 (1988) 334

- 1988PR1C P.B. Price, G. Ren and W.T. Williams, *Bull. Amer. Phys. Soc.* 33 (1988) 1591
- 1988SA12 N.V. Samsonenko, A.L. Samgin and Ch.L. Kathat, *Yad. Fiz.* 47 (1988) 348; *Sov. J. Nucl. Phys.* 47 (1988) 220
- 1988SE04 S.J. Seestrom-Morris, D. Dehnhard, M.A. Franey, D.B. Holtkamp, C.L. Blilie, C.L. Morris, J.D. Zumbro and H.T. Fortune, *Phys. Rev.* C37 (1988) 2057
- 1988SE1A K.K. Seth, *Nucl. Phys.* A478 (1988) 591c
- 1988SM01 M.J. Smithson D.L. Watson and H.T. Fortune, *Phys. Rev.* C37 (1988) 1036
- 1988TA08 M. Tanaka, T. Yamagata, S. Nakayama, M. Inoue, K. Goto, K. Katori, M. Yanagi and H. Ogata, *Nucl. Instrum. Meth. Phys. Res.* A267 (1988) 139
- 1988TR02 M. Trajdos and K. Zajac, *J. Phys.* G14 (1988) 869
- 1988UT02 H. Utsunomiya and R.P. Schmitt, *Nucl. Phys.* A487 (1988) 162
- 1988VAZY S.P. Van Verst, K.W. Kemper, D.E. Trcka, G.A. Hall, V. Hnizdo, K.R. Chapman and B.G. Schmidt, *Bull. Amer. Phys. Soc.* 33 (1988) 1101
- 1988VO1D J.R. Votaw, *Bull. Amer. Phys. Soc.* 33 (1988) 1748
- 1988VO1E J.R. Votaw and R.J. Nickles, *Bull. Amer. Phys. Soc.* 33 (1988) 1738
- 1988WI08 M. Wiescher, J. Gorres and F.-K. Thielemann, *Astrophys. J.* 326 (1988) 384
- 1988YU04 Z.-Q. Yu, C.-H. Cai, W.-H. Ma and S.-P. Zhao, *Phys. Rev.* C38 (1988) 272
- 1989AJ1A F. Ajzenberg-Selove, in *Mikolajki* (1989) 1
- 1989AR1J M. Arnould, F. Baeten, D. Darquennes, Th. Delbar, C. Dom, M. Huyse, Y. Jongen, P. Leleux, M. Lacroix, P. Lipnik et al., *Nucl. Instrum. Meth. Phys. Res.* B40-41 (1989) 498
- 1989BA1R Baer, *Bull. Amer. Phys. Soc.* 34 (1989) 1210
- 1989BA92 H. Bando, *Nuovo Cim.* A102 (1989) 627
- 1989BE1R Belyanin et al., in *Tashkent* (1989) 360
- 1989BEZC J.A. Behr, K.A. Snover, C.A. Gossett, J.H. Gundlach, W. Hering, *Bull. Amer. Phys. Soc.* 34 (1989) 1832
- 1989BO01 G. Bogaert, V. Landre, P. Aguer, S. Barhoumi, M. Kiouss, A. Lefebvre, J.P. Thibaud and D. Bertault, *Phys. Rev.* C39 (1989) 265
- 1989BR1J Brown, in *Sao Paulo* (1989) 187
- 1989CH13 D.C. Choudhury and T. Guo, *Phys. Rev.* C39 (1989) 1883
- 1989CH1O Ching et al., *Commun. Theor. Phys.* 11 (1989) 171
- 1989CH1P Chen and Wu, *High Energy Phys. Nucl. Phys.* 13 (1989) 50
- 1989CH21 H.-C. Chiang and B.-S. Zou, *Nucl. Phys.* A496 (1989) 739

- 1989CI1C Cindro and Bozin, "Heavy Ions in Nucl. and Atomic Phys.," 1988 Mikolajki Summer School on Nucl. Phys., Eds. Wilhelmi and Szefflinska; A. Hilger Publ. (1989) 239
- 1989DE52 C. Detraz and D.J. Vieira, *Ann. Rev. Nucl. Part. Sci.* 39 (1989) 407
- 1989FO02 H.T. Fortune, *Phys. Rev. C* 39 (1989) 192
- 1989FU01 C. Funck, B. Grund and K. Langanke, *Z. Phys.* A332 (1989) 109
- 1989FU06 C. Funck and K. Langanke, *Astrophys. J.* 344 (1989) 46
- 1989FU08 C. Funck, B. Grund and K. Langanke, *Z. Phys.* A334 (1989) 1
- 1989FU1H C. Funck and K. Langanke, *Proc. int. Symp. on Heavy Ion Phys. and Nucl. Astrophys. Problems, Tokyo, 21-23 July 1988*, ed. S. Kubono, M. Ishihara, T. Nomura (World Scientific, 1989) 67
- 1989GA01 M. Gai, S.L. Rugari, R.H. France III, B.J. Lund, Z. Zhao, D.A. Bromley, B.A. Lincoln, W.W. Smith, M.J. Zarfcone and Q.C. Kessel, *Phys. Rev. Lett.* 62 (1989) 874
- 1989GAZW A. Garcia, E.G. Adelberger, D. Markoff and K. Swartz, *Bull. Amer. Phys. Soc.* 34 (1989) 1802
- 1989GE10 P.M. Gensini, *Nuovo Cim.* A102 (1989) 1563
- 1989GE11 C.K. Gelbke, *Nucl. Phys.* A495 (1989) C27
- 1989GR1F Gruszczynski et al., *Nature* 337 (1989) 64
- 1989GR1M Grion and Rui, in *Sao Paulo* (1989) 22
- 1989GU06 I.S. Gulkarov and V.I. Kuprikov, *Yad. Fiz.* 49 (1989) 33; *Sov. J. Nucl. Phys.* 49 (1989) 21
- 1989GU1L Gustafsson, *Ann. Astron. Astrophys.* 27 (1989) 701
- 1989HE21 H. Heiselberg, A.S. Jensen, A. Miranda and G.C. Oades, *Phys. Scr.* 40 (1989) 141
- 1989HJ03 M. Hjorth-Jensen and E. Osnes, *Phys. Lett.* B228 (1989) 281
- 1989JI1A L. Jin, W.D. Arnett and S.K. Chakrabarti, *Astrophys. J.* 336 (1989) 572
- 1989KA1K Kajino, Mathews and Fuller, in *Tokyo 1988* (1989) 51
- 1989KA1S Katoh, Kawade and Yamamoto, *JAERI-M89-083* (1989)
- 1989KA24 F. Kappeler, H. Beer and K. Wisshak, *Rep. Prog. Phys.* 52 (1989) 945
- 1989KAZH A.B. Kabulov, *Prog. and Thesis, Proc. 39th Ann. Conf. Nucl. Spectrosc. Struct. At. Nucl.*, Tashkent (1989) 192
- 1989KU10 P.C.-K. Kuo, J.W. Jury, K.G. McNeill, N.K. Sherman and W.F. Davidson, *Nucl. Phys.* A499 (1989) 328
- 1989KU1P Kudziev, *Nucl. Instrum. Meth. Phys. Res.* A282 (1989) 267
- 1989LA19 V. Landre, P. Aguer, G. Bogaert, A. Lefebvre, J.P. Thibaud, S. Fortier, J.M. Maison and J. Vernotte, *Phys. Rev. C* 40 (1989) 1972

- 1989LE16 M. Lewitowicz, Yu.E. Penionzhkevich, A.G. Artukh, A.M. Kalinin, V.V. Kamanin, S.M. Lukyanov, Nguyen Hoai Chau, A.C. Mueller, D. Guillemaud-Mueller, R. Anne et al., Nucl. Phys. A496 (1989) 477
- 1989LE1L Leitch, "Fund. Symm. and Nucl. Struct.", Eds. Ginocchio and Rosen, in Santa Fe, NM 1988 (World Scientific: 1989) 163
- 1989MA24 J. Mahalanabis and H.V. von Geramb, Nucl. Phys. A493 (1989) 412
- 1989MC1C A.B. McDonald, Can. J. Phys. 67 (1989) 785
- 1989ME1C Mewaldt and Stone, Astrophys. J. 337 (1989) 959
- 1989NA1M Nagashima et al., Sao Paulo (1989) 340
- 1989NO1A Nomoto, Hashimoto, Arai and Kaminisi, Proc. int. Symp. on Heavy Ion Phys. and Nucl. Astrophys. Problems, Tokyo, 21-23 July 1988, ed. S. Kubono, M. Ishihara, T. Nomura (World Scientific, 1989) 9
- 1989NO1C Norbury, Phys. Rev. C40 (1989) 2621
- 1989NW1A Nwosu and Fischbeck, Nucl. Instrum. Meth. Phys. Res. B40-41 (1989) 833
- 1989OG1B A.A. Oglobin and Y.E. Penionzhkevich, Treatise On Heavy-Ion Science, Vol. 8, Ed. D.A. Bromley (Plenum Publ. Corp., 1989) p.261
- 1989OR02 W.E. Ormand and B.A. Brown, Nucl. Phys. A491 (1989) 1
- 1989RA16 S. Raman, C.W. Nestor, Jr. , S. Kahane and K.H. Bhatt, At. Data Nucl. Data Tables 42 (1989) 1
- 1989RA17 P. Raghavan, At. Data Nucl. Data Tables 42 (1989) 189
- 1989RA1G J. Rapaport, Santa Fe 88 (1989) 186
- 1989SA10 M.G. Saint-Laurent, R. Anne, D. Bazin, D. Guillemaud-Mueller, U. Jahnke, Jin Gen-Ming, A.C. Mueller, J.F. Bruandet, F. Glasser, S. Kox et al., Z. Phys. A332 (1989) 457
- 1989SA1H N.V. Samsonenko, C.L. Kathat and A.L. Samgin, Nucl. Phys. A491 (1989) 642
- 1989SA1P Sakutal, Tashkent (1989) 380
- 1989SP01 R.H. Spear, At. Data Nucl. Data Tables 42 (1989) 55
- 1989ST1H Strottman, "Fund. Symm. and Nucl. Struct.". Eds. Ginocchio and Rosen, in Santa Fe, NM 1988 (World Scientific: 1989) 247
- 1989TA1Y Tanaka et al., Nature 341 (1989) 727
- 1989TA32 Tanaka, Phys. Lett. B227 (1989) 195
- 1989TE02 F. Terrasi, A. Brondi, G. La Rana, G. De Angelis, A. D'Onofrio, R. Moro, E. Perillo and M. Romano, Phys. Rev. C40 (1989) 742



- 1989TH1C Thielemann and Wiescher, Proc. int. Symp. on Heavy Ion Phys. and Nucl. Astrophys. Problems, Tokyo, 21-23 July 1988, ed. S. Kubono, M. Ishihara, T. Nomura (World Scientific, 1989) 27
- 1989TR18 M. Traidos and K. Zaionts, *Izv. Akad. Nauk SSSR, Ser. Fiz.* 53 (1989) 2225; *Bull. Acad. Sci. USSR, Phys. Ser.* 53 (1989) 173
- 1989VA04 S. P. Van Verst, D. P. Sanderson, D. E. Trcka, K. W. Kemper, V. Hnizdo, B. G. Schmidt and K. R. Chapman, *Phys. Rev.* C39 (1989) 853
- 1989VAZM G.S. Valiev, I.R. Gulamov, T. Iskhakov, A.A. Karakhodzhaev, A.M. Mukhamedzhanov, G.K. Ni and E.A. Pak, Proc. 39th Ann. Conf. Nucl. Spectrosc. Struct. At. Nuclei, Tashkent, USSR, 18-21 April 1989 (Nauka, 1989) 274
- 1989VOZM V.V. Volkov, *Treatise on Heavy-Ion Science*, Plenum Press, New York, Vol. 8 (1989)101
- 1989WAZZ J.W. Watson, B.D. Anderson, A.R. Baldwin, R. Madey, M.R. Plumley, J. Schambach, P.J. Pella and C.C. Foster, *Bull. Amer. Phys. Soc.* 34 (1989) 1142
- 1989WH1B Wheeler, Sneden and Truran, *Ann. Rev. Astron. Astrophys.* 27 (1989) 279
- 1989WI02 A.L. Williams, L. Agnew, L.G. Atencio, H.W. Baer, M. Burlein, G.R. Burseson, K.S. Dhuga, H.T. Fortune, G.S. Kyle, J.A. McGill et al., *Phys. Lett.* B216 (1989) 11
- 1989WO1B Wood, *Bull. Amer. Phys. Soc.* 34 (1989) 1133
- 1989YO02 A. Yokoyama, T. Saito, H. Baba, K. Hata, Y. Nagame, S. Ichikawa, S. Baba, A. Shinohara and N. Imanishi, *Z. Phys.* A332 (1989) 71
- 1989YU1A Yu, Cai and Ma, Sao Paulo (1989) 9
- 1989ZH04 Z. Zhao, M. Gai, B.J. Lund, S.L. Rugari, D. Mikolas, B.A. Brown, J.A. Nolen, Jr. and M. Samuel, *Phys. Rev.* C39 (1989) 1985
- 1989ZH05 R.-R. Zheng, K.W. Schmid, F. Grummer and A. Faessler, *Nucl. Phys.* A494 (1989) 214
- 1990AR10 M. Arnould and M. Rayet, *Ann. Physique* 15 (1990) 783
- 1990BA1S E.H. Bakraji, A. Giovagnoli, G. Blondiaux and J.-L. Debrun, *Nucl. Instrum. Meth. Phys. Res.* B50 (1990) 65
- 1990BR13 D.S. Brenner, C. Wesselborg, R.F. Casten, D.D. Warner and J.-Y. Zhang, *Phys. Lett.* B243 (1990) 1
- 1990BR26 B.A. Brown, *Phys. Rev. Lett.* 65 (1990) 2753
- 1990CH14 C. Ching, T. Ho and B. Zou, *Nucl. Phys.* A510 (1990) 630
- 1990CH1I R.J. Chater, J.A. Kilner, K.J. Reeson, A.K. Robinson and P.L.F. Hemment, *Nucl. Instrum. Meth. Phys. Res.* B45 (1990) 110
- 1990CH1U Ching, Ho and Zou, *Panic XII* (1990) Paper III-77

- 1990CO1K D.D. Cohen, S.D. Bradshaw, F.J. Bradshaw and A. Katsaros, Nucl. Instrum. Meth. Phys. Res. B50 (1990) 43
- 1990GAZR A. Garcia, E.G. Adelberger, D. Markoff, K. Swartz, M.S. Smith, P.V. Magnus and K.I. Hahn, Bull. Amer. Phys. Soc. 35 (1990) 1400
- 1990GAZW A. Garcia, E.G. Adelberger, D.K. Swartz, M.S. Smith, P.V. Magnus and K.I. Hahn, Bull. Amer. Phys. Soc. 35 (1990) 1074
- 1990GL01 A. Glaesner, W. Dünneweber, M. Bantel, W. Hering, D. Konnerth, R. Ritzka, W. Trautmann, W. Trombik and W. Zipper, Nucl. Phys. A509 (1990) 331
- 1990GU10 I.S. Gulkarov, Sov. J. Nucl. Phys. 51 (1990) 61
- 1990HJ01 M. Hjorth-Jensen and E. Osnes, Phys. Scr. 41 (1990) 207
- 1990HJ03 M. Hjorth-Jensen, E. Osnes, H. Müther and K.W. Schmid, Phys. Lett. B248 (1990) 243
- 1990KA1F N. Kaiser and U.-G. Meissner, Nucl. Phys. A510 (1990) 759
- 1990LE08 J.H. Lee, W. Benenson and D.J. Morrissey, Phys. Rev. C41 (1990) 1562
- 1990LI1J D. Lissauer and H. Takai, Phys. Rev. C41 (1990) 2410
- 1990LO11 R.J. Lombard, J. Phys. G16 (1990) 1311
- 1990MA06 D.M. Manley, D.J. Millener, B.L. Berman, W. Bertozzi, T.N. Buti, J.M. Finn, F.W. Hersmann, C.E. Hyde-Wright, M.V. Hynes, J.J. Kelly et al., Phys. Rev. C41 (1990) 448
- 1990MA1Z R.A. Malaney, in Chapel Hill (1990) 49
- 1990MAZW W.-H. Ma, L.S. Kisslinger and S.-W. Wang, Bull. Amer. Phys. Soc. 35 (1990) 1017
- 1990MI01 H. Miyake and A. Mizukami, Phys. Rev. C41 (1990) 329
- 1990MI15 I.V. Mitchell, G.R. Massoumi, W.N. Lennard, S.Y. Tong, P.F.A. Alkemade, K. Griffiths, S.J. Bushby and P.R. Norton, Nucl. Instrum. Meth. Phys. Res. B45 (1990) 107
- 1990MO13 M. Moosburger, E. Aschenauer, H. Dennert, W. Eyrich, A. Lehamn, R. Rudeloff, H. Schlösser, H. Wirth, H.J. Fils, H. Rebel et al., Phys. Rev. C41 (1990) 2925
- 1990NO1A J.W. Norbury, Phys. Rev. C42 (1990) 711
- 1990OS03 A. Osman and A.A. Farra, Nuovo Cim. A103 (1990) 1693
- 1990PH02 D.L. Pham and R.de Swiniarski, Nuovo Cim. A103 (1990) 375
- 1990PO04 I.V. Poplavsky, Yad. Fiz. 51 (1990) 1258; Sov. J. Nucl. Phys. 51 (1990) 799
- 1990SA1J A. Sarkar, R. Ramesh, S.K. Bhattacharya and G. Rajagopalan, Nature 343 (1990) 549
- 1990SEZZ R.M. Sellers, D.M. Manley, R.A. Lindgren, B.L. Clausen, M. Farkhondeh, B.E. Norum, R.J. Peterson, B.L. Berman and C.E. Hyde-Wright, Bull. Amer. Phys. Soc. 35 (1990) 927
- 1990SK04 L.D. Skouras and J.C. Varvitsiotis, Nucl. Phys. A513 (1990) 239



- 1990SK07 L.D. Skouras and H. Muther, Nucl. Phys. A515 (1990) 93
- 1990SN1A K. Snover, Bull. Amer. Phys. Soc. 35 (1990) 1032
- 1990ST08 A. Staudt, E. Bender, K. Muto and H.V. Klapdor-Kleingrothaus, At. Data Nucl. Data Tables 44 (1990) 79
- 1990ST1G J. Stutzki and R. Gusten, Astrophys. J. 356 (1990) 513
- 1990SZ1C A. Szanto de Toledo, Proc. 1989 Int. Nucl. Phys. Conf., Sao Paulo, Brasil, 20-26 Aug.1989 (World Scientific, 1989) 607
- 1990TH1C F.-K. Thielemann, M.-A. Hashimoto and K. Nomoto, Astrophys. J. 349 (1990) 222
- 1990TH1E F.-K. Thielemann and M. Wiescher, in Chaprl Hill (1990) 92
- 1990TO1F M. Toriseva, L. Bronfman and K. Mattila, Astrophys. Space Sci. 171 (1990) 219
- 1990WA10 S. Wa-Kitwanga, P. Leleux, P. Lipnik and J. Vanhorenbeeck, Phys. Rev. C42 (1990) 748
- 1990WAZT J.W. Watson, M. Rahi, B.D. Anderson, A.R. Baldwin, R. Madey, M.R. Plumley, J. Schambach, P.J. Pella and C.C. Foster, Bull. Amer. Phys. Soc. 35 (1990) 1659
- 1990WE14 W.R. Webber, J.C. Kish and D.A. Schrier, Phys. Rev C41 (1990) 520
- 1990WI1K Williams et al., Int. Conf. on Part. and Nucl., Cambridge, Mass., 25-29 June 1990 (Organizing Committee, 1990) Paper III-68
- 1990WIZP M. Wiescher, J. Görres, S. Graff, R.E. Azuma, C.a. Barnes and T.R. Wang, Bull. Amer. Phys. Soc. 35 (1990) 1673
- 1990XE01 A.C. Xenoulis, A.E. Aravatinos, G.P. Eleftheriades, C.T. Papadopoulos, E.N. Gazis and R. Vlastou, Nucl. Phys. A516 (1990) 108
- 1991AJ01 F. Ajzenberg-Selove, Nucl. Phys. A523 (1991) 1
- 1991BA62 E.H. Bakraji, G. Ducouret, G. Blondiaux and J.L. Debrun, Nucl. Instr. Meth. Phys.Res. B56/57 (1991) 819
- 1991GA03 A. Garcia, E.G. Adelberger, P.V. Magnus, D.M. Markoff, K.B. Swartz, M.S. Smith, K.I. Hahn, N. Bateman and P.D. Parker, Phys. Rev. C43 (1991) 2012
- 1991GA08 M. Gai, M. Ruscev, D.A. Bromley and J.W. Olness, Phys. Rev. C43 (1991) 2127
- 1991GU05 M. Guillaume, A. Luxen, B. Nebeling, M. Argentini, J.C. Clark and V.W. Pike, Appl. Radiat. Isot. 42 (1991) 749
- 1991HA17 C.L. Hartmann and P.M. DeLuca, Jr., Nucl. Sci. Eng. 109 (1991) 319
- 1991HI15 K. Hida and S. Iijima, J. Nucl. Sci. Technol. 28 (1991) 447
- 1991KO1P P.E. Koehler and H.A. O'Brien, in AIP Conf. Proc. 238 (1991) 892
- 1991KO31 P.E. Koehler and S.M. Graff, Phys. Rev. C44 (1991) 2788
- 1991LE33 J.A. Leavitt and L.C. McIntyre Jr., Nucl. Instrum. Meth. Phys. Res. B56-57 (1991) 734

- 1991MA14 D.M. Manley, B.L. Berman, W. Bertozzi, T.N. Buti, J.M. Finn, F.W. Hersman, C.E. Hyde-Wright, M.V. Hynes, J.J. Kelly and M.A. Kovash et al., Phys. Rev. C43 (1991) 2147
- 1991MC01 K.G. McNeill, J.W. Jury, M.N. Thompson, B.L. Berman and R.E. Pywell, Phys. Rev. C43 (1991) 489
- 1991MO13 C.L. Morris, Nucl. Phys. A527 (1991) 433C
- 1991OS01 E. Oset and D. Strottman, Phys. Rev. C44 (1991) 468
- 1991PR03 M.S. Pravikoff, F. Hubert, R. Del Moral, J.-P. Dufour, A. Fleury, D. Jean, A.C. Mueller, K.-H. Schmidt, K. Summerer, E. Hanelt et al., Nucl. Phys. A528 (1991) 225
- 1991RE02 P.L. Reeder, R.A. Warner, W.K. Hensley, D.J. Vieira and J.M. Wouters, Phys. Rev. C44 (1991) 1435
- 1991SA1F L.J. Sage, R. Mauersberger and C. Henkel, Astron. Astrophys. 249 (1991) 31
- 1991SU17 M. Suehiro, T. Nozaki, T. Sasaki, H. Suzuki, M. Senda, H. Toyama and S.-I. Ishii, Appl. Radiat. Isot. 42 (1991) 1231
- 1991UE01 K. Ueta and G.W. Bund, Phys. Rev. C43 (1991) 2887
- 1992AR18 K.P. Artemov, M.S. Golovkov, V.Z. Goldberg, V.V. Pankratov, A.E. Pakhomov, I.N. Serikov and V.A. Timofeev, Yad. Fiz. 55 (1992) 2615; Sov. J. Nucl. Phys. 55 (1992) 1460
- 1992AV03 M.P. Avotina, K.I. Erokhina and I.K.H.Lemberg, Sov. J. Nucl. Phys. 55 (1992) 1777; Yad. Fiz. 55 (1992) 3189
- 1992BE21 M. Berheide, C. Rolfs, U. Schroder and H.P. Trautvetter, Z. Phys. A343 (1992) 483
- 1992CO08 D.D. Cohen, G.M. Bailey and N. Dytlewski, Nucl. Instrum. Meth. Phys. Res. B64 (1992) 413
- 1992DI04 F. Ditroi, S. Takacs, I. Mahunka, P. Mikecz and Gy. Toth, Nucl. Instrum. Meth. Phys. Res. B68 (1992) 166
- 1992FR01 G. Fricke, J. Herberz, Th. Hennemann, G. Mallot, L.A. Schaller, L. Schellenberg, C. Piller and R. Jacot-Guillarmod, Phys. Rev. C45 (1992) 80
- 1992GA11 M. Gai, Phys. Rev. C45 (1992) R2548
- 1992GO14 J. Gorres, S. Graff, M. Wiescher, R.E. Azuma, C.A. Barnes and T.R. Wang, Nucl. Phys. A548 (1992) 414
- 1992GU11 I.S. Gulkarov, Yad. Fiz. 55 (1992) 2024; Sov. J. Nucl. Phys. 55 (1992) 1123
- 1992HAZZ K.I. Hahn, N. Bateman, B.J. Lund, S. Utku, A.J. Howard and P.D. Parker, Bull. Amer. Phys. Soc. 37 (1992) 868
- 1992HE12 E.M. Henley and I.B. Khriplovich, Phys. Lett. B289 (1992) 223
- 1992HJ01 M. Hjorth-Jensen, E. Osnes and H. Muther, Ann. Phys. (New York) 213 (1992) 102

- 1992JI04 M.F. Jiang, R. Machleidt, D.B. Stout and T.T.S. Kuo, Phys. Rev. C46 (1992) 910
- 1992JOZZ J.D. Johnson, C.F. Moore, K.W. Johnson, H. Ward, C. Whitley, A. Hussein, R.W. Garnett, L.C. Liu, C.L. Morris, J.M. O'Donnell et al., Bull. Amer. Phys. Soc. 37 (1992) 916
- 1992LA08 D.W. Lane, Nucl. Instrum. Meth. Phys. Res. B64 (1992) 448
- 1992LA13 M. Lassaut and R.J. Lombard, Z. Phys. A341 (1992) 125
- 1992LA25 M.C. Lagunas-Solar, O.F. Carvacho and P.M. Smith-Jones, Appl. Radiat. Isot. 43 (1992) 1005
- 1992LI1K G. Liu, D. Fu and X. Cheng, Chin. Phys. Lett. 9 (1992) 577
- 1992MA46 W. Ma, D. Strottman, Q. Wu, L.S. Kisslinger and S. Wang, Chin. J. Nucl. Phys. 14 (1992) 197
- 1992OS01 E. Osnes and D. Strottman, Phys. Rev. C45 (1992) 662
- 1992OS05 E. Oset, M. Khankhasayev, J. Nieves, H. Sarafian and M.J. Vicente-Vacas, Phys. Rev. C46 (1992) 2406
- 1992TA08 K. Tamura, Y. Oki, Y. Sakamoto and J. Mahalanabis, Nuovo Cim. A105 (1992) 203
- 1992WA22 E.K. Warburton and B.A. Brown, Phys. Rev. C46 (1992) 923
- 1992YA08 M. Yasue, T. Hasegawa, S.I. Hayakawa, K. Ieki, J. Kasagi, S. Kubono, T. Murakami, K. Nisimura, K. Ogawa, H. Ohnuma et al., Phys. Rev. C46 (1992) 1242
- 1992ZH15 Z. Zhao, C.Y. Fu and D.C. Larson, Chin. J. Nucl. Phys. 14 (1992) 67
- 1993AB18 S.N. Abramovich, B. Ya. Guzhovsky, L.N. Generalov, S.A. Dunaeva, V.N. Protopopov, A.P. Solodovnikov and V.V. Chulkov, Bull. Russ. Acad. Sci. Phys. 57:10 (1993) 1832; Izv. Akad. Nauk Ser. Fiz. 57:10 (1993) 187
- 1993AN08 R.M. Anjos, C. Tenreiro, A.S. De Toledo and S.J. Sanders, Nucl. Phys. A555 (1993) 621
- 1993AU05 G. Audi and A.H. Wapstra, Nucl. Phys. A565 (1993) 1
- 1993CH06 W.T. Chou, E.K. Warburton and B.A. Brown, Phys. Rev. C47 (1993) 163
- 1993CU01 B. Cujec, Nucl. Phys. A552 (1993) 267
- 1993CU05 J.B. Cumming, Y.Y. Chun and P.E. Haustein, Phys. Rev. C48 (1993) 2068
- 1993DA17 B. Dasmahapatra, B. Cujec, G. Kajrys and J.A. Cameron, Nucl. Phys. A564 (1993) 314
- 1993DR03 M. Drogg and D.M. Drake, Nucl. Instrum. Meth. Phys. Res. B73 (1993) 387
- 1993DR04 M. Drogg, D.M. Drake, R.C. Haight and R.O. Nelson, Nucl. Instrum. Meth. Phys. Res. B73 (1993) 392
- 1993EG04 J.L. Egido, L.M. Robledo and Y. Sun, Nucl. Phys. A560 (1993) 253
- 1993EN03 P.M. Endt, At. Data Nucl. Data Tables 55 (1993) 171

- 1993GA1G M. Gai, *Prog. Part. Nucl. Phys.* 30 (1993) 415
- 1993GI03 R. Gilman, H.T. Fortune and M. Kagarlis, *Phys. Rev. C* 48 (1993) 366
- 1993HI08 Hirsch et al., *At. Data Nucl. Data Tables* 53 (1993) 165
- 1993JO03 J.D. Johnson, G.R. Burlison, C. Edwards, M. El-Ghossain, M.A. Espy, R. Garnett, A. Hussein, K. Johnson, C.F. Moore, C.L. Morris et al., *Phys. Rev. C* 47 (1993) 2571
- 1993MA1M R.A. Malaney and G.J. Mathews, *Phys. Rep.* 229 (1993) 145
- 1993MC02 K.G. McNeill, M.N. Thompson, A.D. Bates, J.W. Jury and B.L. Berman, *Phys. Rev. C* 47 (1993) 1108
- 1993OS01 E. Oset and D. Strottman, *Phys. Rev. Lett.* 70 (1993) 146
- 1993PA14 S.K. Patra, *Nucl. Phys. A* 559 (1993) 173
- 1993PA19 S.K. Patra, *Phys. Rev. C* 48 (1993) 1449
- 1993PE19 R.J. Peterson, *Acta Phys. Pol. B* 24 (1993) 1877
- 1993RE03 G. Reidemeister and F. Michel, *Phys. Rev. C* 47 (1993) R1846
- 1993SU08 T. Suzuki, M. Fujimaki, S. Hirenzaki, N. Inabe, T. Kobayashi, T. Kubo, T. Nakagawa, Y. Watanabe, I. Tanihata and S. Shimoura, *Phys. Rev. C* 47 (1993) 2673
- 1993TI07 D.R. Tilley, H.R. Weller and C.M. Cheves, *Nucl. Phys. A* 564 (1993) 1
- 1994BE29 H. Beer, *Acta Phys. Pol. B* 25 (1994) 629
- 1994BO1H R.N. Boyd, *Int. J. Mod. Phys. E* 1 Suppl. (1994) 249
- 1994CI02 O. Civitarese and M. Schvellinger, *Phys. Rev. C* 49 (1994) 1976
- 1994HA17 S. Haddad and M.K. Weigel, *Phys. Rev. C* 49 (1994) 3228
- 1994LU01 D.H. Lu and R.H. Landau, *Phys. Rev. C* 49 (1994) 878
- 1994ME02 B. Meltzow, E.K. Warburton, Ch. Ender, J. Gerl, D. Habe, U. Lauff, J. Schirmer, D. Schwalm and P. Thirolf, *Phys. Rev. C* 49 (1994) 743
- 1994ME07 D.J. Mercer, J. Rapaport, C.A. Whitten, D. Adams, R. Byrd, X.Y. Chen, A. Fazely, T. Gaussiran, E. Gülmez, C. Goodman et al., *Phys. Rev. C* 49 (1994) 3104
- 1994RE01 E.L. Reber, K.W. Kemper, P.V. Green, P.L. Kerr, A.J. Mendez, E.G. Myers and B.G. Schmidt, *Phys. Rev. C* 49 (1994) R1
- 1994SC01 K.W. Scheller, J. Gorres, J.G. Ross, M. Wiescher, R. Harkewicz, D.J. Morrissey, B.M. Sherrill, M. Steiner, N.A. Orr and J.A. Winger, *Phys. Rev. C* 49 (1994) 46
- 1994VE04 J. Vernotte, G. Berrier-Ronsin, J. Kalifa, R. Tamisier and B.H. Wildenthal, *Nucl. Phys. A* 571 (1994) 1
- 1995SE02 R.M. Sellers, D.M. Manley, M.M. Niboh, D.S. Weerasundara, R.A. Lindgren, B.L. Clausen, M. Farkhondeh, B.E. Norum and B.L. Berman, *Phys. Rev. C* 51 (1995) 1926