

Energy Levels of Light Nuclei $A = 6$

D.R. Tilley ^{a,b}, C.M. Cheves ^{a,c}, J.L. Godwin ^{a,c}, G.M. Hale ^d,
H.M. Hofmann ^e, J.H. Kelley ^{a,b}, C.G. Sheu ^{a,c} and H.R. Weller ^{a,c}

^a*Triangle Universities Nuclear Laboratory, Durham, NC 27708-0308*

^b*Department of Physics, North Carolina State University, Raleigh, NC 27695-8202*

^c*Department of Physics, Duke University, Durham, NC 27708-0305*

^d*Los Alamos National Laboratory, Los Alamos, NM 87545*

^e*Universität Erlangen-Nürnberg, Erlangen, Germany*

Abstract: An evaluation of $A = 5-7$ was published in *Nuclear Physics A708* (2002), p. 3. This version of $A = 6$ differs from the published version in that we have corrected some errors discovered after the article went to press. The introduction and introductory tables have been omitted from this manuscript. [Reference](#) key numbers are in the NNDC/TUNL format.

(References closed August 23, 2001)

This work is supported by the US Department of Energy, Office of High Energy and Nuclear Physics, under: Contract No. DEFG02-97-ER41042 (North Carolina State University); Contract No. DEFG02-97-ER41033 (Duke University).

Table of Contents for $A = 6$

Below is a list of links for items found within the PDF document. The introductory [Table 3](#) is available on this website via the link.

A. Nuclides: $A = 6$, [\${}^6\text{n}\$](#) , [\${}^6\text{H}\$](#) , [\${}^6\text{He}\$](#) , [\${}^6\text{Li}\$](#) , [\${}^6\text{Be}\$](#) , [\${}^6\text{B}\$](#) , [\${}^6\text{C}\$](#)

B. Tables of Recommended Level Energies:

[Table 6.1](#): Energy levels of ${}^6\text{He}$

[Table 6.4](#): Energy levels of ${}^6\text{Li}$

[Table 6.14](#): Energy levels of ${}^6\text{Be}$

C. [References](#)

D. General Tables: [\${}^6\text{He}\$](#) , [\${}^6\text{Li}\$](#) , [\${}^6\text{Be}\$](#)

E. Figures: [\${}^6\text{He}\$](#) , [\${}^6\text{Li}\$](#) , [\${}^6\text{Be}\$](#) , [Isobar diagram](#)

F. Erratum to this Publication: [PS](#) or [PDF](#)

A = 6

GENERAL: References to articles on general properties of $A = 6$ nuclei published since the previous review (1988AJ01) are grouped into categories and listed, along with brief descriptions of each item, in the General Tables for $A = 6$ located on our website at (www.tunl.duke.edu/NuclData/General_Tables/06.shtml).

${}^6\text{n}$

(Not illustrated)

${}^6\text{n}$ has not been observed. See (1979AJ01, 1988AJ01) and references cited there. More recently (1990AL40) reports a search for ${}^6\text{n}$ in a ${}^{14}\text{C}({}^7\text{Li}, {}^6\text{n})$ activation experiment at $E({}^7\text{Li}) = 82$ MeV. No evidence for ${}^6\text{n}$ was obtained.

The method of angular potential functions was used by (1989GO18) in a calculation of the properties of multi-neutron systems which indicated that these systems have no bound states. The ground state energy of a six-neutron drop has been computed with variational and Green's function Monte Carlo methods (1997SM07).

${}^6\text{H}$

(Fig. 7)

${}^6\text{H}$ was reported in the ${}^7\text{Li}({}^7\text{Li}, {}^8\text{B}){}^6\text{H}$ reaction at $E({}^7\text{Li}) = 82$ MeV (1984AL08, 1985AL1G) [$\sigma(\theta) \approx 60$ nb/sr at $\theta = 10^\circ$] and in the ${}^9\text{Be}({}^{11}\text{B}, {}^{14}\text{O}){}^6\text{H}$ reaction at $E({}^{11}\text{B}) = 88$ MeV (1986BE35) [$\sigma(\theta) \approx 16$ nb/sr at $\theta \approx 8^\circ$]. ${}^6\text{H}$ is unstable with respect to breakup into ${}^3\text{H} + 3\text{n}$ by 2.7 ± 0.4 MeV, $\Gamma = 1.8 \pm 0.5$ MeV (1984AL08), 2.6 ± 0.5 MeV, $\Gamma = 1.3 \pm 0.5$ MeV (1986BE35). The value adopted in the previous review (1988AJ01) is 2.7 ± 0.3 MeV, $\Gamma = 1.6 \pm 0.4$ MeV. See also (1987BO40). The atomic mass excess of ${}^6\text{H}$ using the (1995AU04) masses for ${}^3\text{H}$ and n, is then 41.9 ± 0.3 MeV. There is no evidence for the formation of ${}^6\text{H}$ in the ${}^6\text{Li}(\pi^-, \pi^+)$ reaction at $E_{\pi^-} = 220$ MeV as reported in (1990PA25). (1991SE06) shows that the continuum missing mass spectra can be explained in terms of the presence of dineutrons in the breakup products. An analysis of the proton spectra for the ${}^7\text{Li}(\pi^-, \text{p})$ reaction (1990AM04) showed no evidence for ${}^6\text{H}$.

The ground state of ${}^6\text{H}$ is calculated to have $J^\pi = 2^-$. Excited states are predicted at 1.78, 2.80 and 4.79 MeV with $J^\pi = 1^-, 0^-$ and 1^+ [$(0+1)\hbar\omega$ model space] (1985PO10) [see also for $(0+2)\hbar\omega$ calculations]. See also the additional references cited in (1988AJ01).

${}^6\text{He}$
(Figs. 4 and 7)

GENERAL: References to articles on general properties of ${}^6\text{He}$ published since the previous review (1988AJ01) are grouped into categories and listed, along with brief descriptions of each item, in the General Tables for ${}^6\text{He}$ located on our website at (www.tunl.duke.edu/NuclData/General_Tables/6he.shtml).

Ground State Properties:

The interaction radius of ${}^6\text{He}$, obtained from measurements of the total interaction cross section, is 2.18 ± 0.02 fm (1985TA13, 1985TA18). These authors have also derived nuclear matter, charge and neutron r.m.s. radii.

${}^6\text{He}$ is considered to be a neutron-halo nucleus because its interaction radius, which is deduced from the total interaction cross section in (1985TA13, 1985TA18), is appreciably larger than that of ${}^6\text{Li}$. A Glauber calculation using proton and neutron densities from an alpha-core valence-neutron model leads to the conclusion that the matter radius is much larger than the charge radius, as predicted by theoretical models of the ${}^6\text{He}$ ground-state wave function. These theoretical models include three-body models (1993ZH1J, 1995HI15), cluster-orbital shell models (1991SU03, 1994FU04), no-core microscopic shell models (1996NA24), and microscopic cluster models for various effective nucleon-nucleon interactions (1993CS04, 1997WU01). See also (1992TA18). The point proton and point neutron radii are often compared in order to enhance the effect, and are found to differ by 0.4–0.8 fm. For other typical properties of halo nuclei see (1995HA56).

1. ${}^6\text{He}(\beta^-){}^6\text{Li}$ $Q_m = 3.508$

The half-life is 806.7 ± 1.5 ms (1984AJ01). The decay to the ground state of ${}^6\text{Li}$ ($J^\pi = 1^+$) is via a super-allowed Gamow-Teller transition; $\log ft = 2.910 \pm 0.002$ (1984AJ01, 1988AJ01). A second beta-decay branch leading to an unbound final state consisting of a deuteron and an α particle was reported (1990RI01) based on the observation of beta-delayed deuterons. The branching ratio for $E_d > 350$ keV was measured (1993BO24, 1993RIZY) to be $(7.6 \pm 0.6) \times 10^{-6}$. Calculations are presented which consider alternative decay routes. (One considers a decay to an unbound state of ${}^6\text{Li}$ which then decays into $\alpha + d$. In the other route ${}^6\text{He}$ breaks up into an alpha particle plus a di-neutron which β decays to a deuteron). The calculation of (1994BA11) successfully reproduces the deuteron spectrum shape and branching ratios. References to theoretical work on the ${}^6\text{He}(\beta^-){}^6\text{Li}$ decay are presented in Table 6.2.

2. ${}^1\text{H}({}^6\text{He}, {}^6\text{He}){}^1\text{H}$ $E_b = 9.975$

Angular distributions for elastic scattering and for 1n and 2n transfer were measured at 25 MeV/A, and spectroscopic amplitudes were extracted by (1999WO13). An analysis of elastic

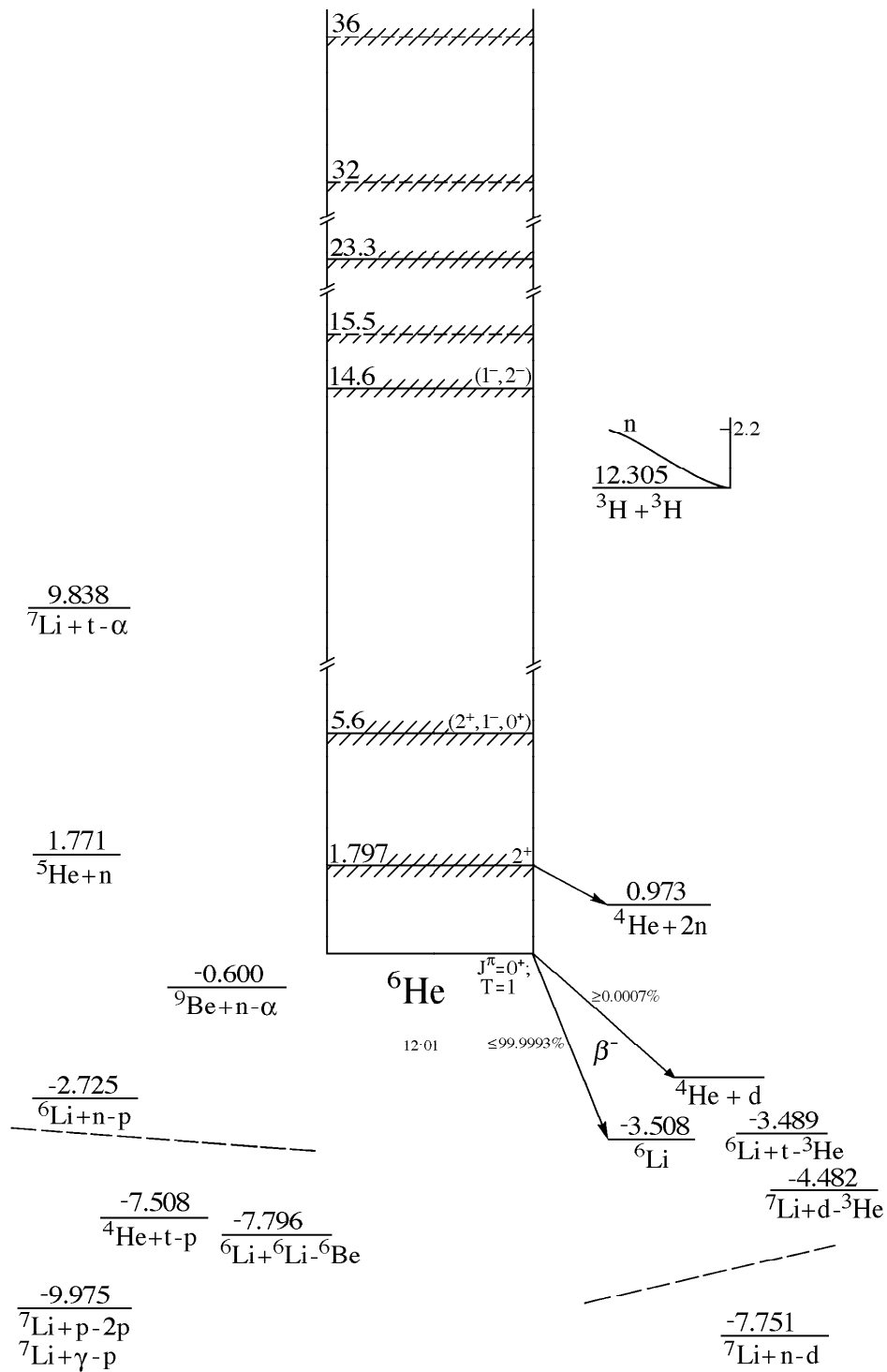

Figure 4: Energy levels of ${}^6\text{He}$. For notation see Fig. 5.

Table 6.1: Energy levels of ${}^6\text{He}$

E_x (MeV \pm keV)	$J^\pi; T$	$\tau_{1/2}$ or Γ_{cm}	Decay	Reactions
g.s.	$0^+; 1$	$\tau_{1/2} = 806.7 \pm 1.5$ ms	β^-	1, 5, 9, 10, 11, 12, 13, 14, 15, 16, 19, 20, 21, 22, 23, 24, 25, 30, 31
1.797 ± 25	$2^+; 1^a$	$\Gamma = 113 \pm 20$ keV	n, α	5, 9, 10, 11, 12, 13, 15, 16, 19, 20, 21, 22, 23, 24, 26, 31
5.6 ± 300^a	$(2^+, 1^-, 0^+); 1^a$	12.1 ± 1.1 MeV a		15
14.6 ± 0.7^a	$(1^-, 2^-); 1^a$	7.4 ± 1.0 MeV a		9, 15, 19, 22, 24
(15.5 ± 500)		4 ± 2 MeV		10, 11, 16, 19, 23, 24
23.3 ± 1.0^a		14.8 ± 2.3 MeV a		11, 15, 19
(32)		≤ 2 MeV		23
(36)		≤ 2 MeV		23

^a Newly adopted in this evaluation or revised from the previous evaluation (1988AJ01).

scattering data at 700 MeV/A is described in (1998AL05). See also the analysis (2000DE43) of data at $E = 25, 40$ MeV and that of (2000GU19) at $E = 25\text{--}70$ MeV. The reaction cross section was measured for 36 MeV/A ${}^6\text{He}$ on hydrogen, and a value of $\sigma_R = 409 \pm 22$ mb was obtained (2001DE19). Analysis within a microscopic model allowed the ${}^6\text{He}$ density distribution to be explored.

The use of elastic and inelastic scattering with secondary beams to probe ground-state transition densities of halo nuclei has been explored in a theoretical study (1995BE26). Cross sections for $E = 151$ MeV were calculated by (2000AV02), and density-distribution features were deduced. See also the discussion of (1999EG02).

3. (a) ${}^3\text{H}(t, n){}^5\text{He}$ $Q_m = 10.534$ $E_b = 12.305$
 (b) ${}^3\text{H}(t, 2n){}^4\text{He}$ $Q_m = 11.332$
 (c) ${}^3\text{H}(t, t){}^3\text{H}$

The cross section for reaction (b) was measured for $E_t = 30$ to 115 keV by (1986BR20, 1985JA16) who also calculated the astrophysical S -factors [the extrapolated $S(0) \approx 180$ keV·b] and discussed the earlier measurements. See also (1974AJ01, 1979AJ01) and (1986JA1E). Calculations have also been made within the framework of the two-channel resonating group method

Table 6.2: ${}^6\text{He}(\beta^-){}^6\text{Li}$ – Theoretical work

Reference	Description
1989DO1B	Meson exchange corrections to the ${}^6\text{He}_{g.s.}-{}^6\text{Li}_{g.s.}$ beta decay
1989SA20	Polarization effects of second-class currents in the direct and inverse decay of nuclei
1989TE04	Neutral current effect in nuclear β -decays
1990DA1H	Two body phase space in alpha-deuteron breakup at 40 MeV
1990DAZR	Beta-decay of the ground state of ${}^6\text{He}$ in three-particle $\alpha + 2n$ model
1990DO04	Particle-hole symmetry and meson exchange corrections to the ${}^6\text{He}$ beta decay amplitude
1990HA29	A review of recent results on nuclear structure at the drip lines
1991DA24	Decay of the ground state of the ${}^6\text{He}$ nucleus in the three-particle $\alpha + 2n$ model
1992DAZV	Static electromagnetic characteristics and beta-decay of ${}^6\text{He}$
1992DE12	Beta-delayed deuteron emission of ${}^6\text{He}$ in a potential model
1993CH06	Gamow-Teller beta-decay rates for $A \leq 18$ nuclei, a comprehensive analysis
1993ZH09	${}^6\text{He}$ beta decay to the $\alpha + d$ channel in a three-body model
1994BA11	Deuteron emission following ${}^6\text{He}$ beta decay
1994BB03	Evidence for halo in quenching of ${}^6\text{He}$ β -decay into alpha and deuteron
1994CS01	Microscopic description of the beta delayed deuteron emission from ${}^6\text{He}$
1994SK01	Improved limits on time-reversal-violating, tensor weak couplings in ${}^6\text{He}$
1994SU02	Glauber theory microscopic analysis of fragmentation and beta-delayed particle emission
1995SU13	Study of halo structure in light nuclei with a multicluster model
1998GL01	Order- α radiative correction to ${}^6\text{He}$ β -decay recoil spectrum
1999ER02	Antisymmetrization in multicluster model & nucleon exchange effects

(1989VA20), the microscopic multichannel resonating group method (1991TY01) and the generator coordinate method (1990FU1H). For muon-catalyzed fusion see (1988MA1V, 1989BR23, 1989CH2F, 1990HA46). For earlier work see (1988AJ01).

4. ${}^4\text{He}(2n, \gamma){}^6\text{He}$ $Q_m = 0.973$

A mechanism for this reaction in astrophysical processes is suggested, and a reaction rate is calculated (1996EF02).

5. ${}^4\text{He}(t, p){}^6\text{He}$ $Q_m = -7.508$

Angular distributions of the protons to ${}^6\text{He}^*(0, 1.80)$ have been measured at $E_t = 22$ and 23 MeV. [No L -values were assigned.] No other states are observed with $E_x \leq 4.2$ MeV: see (1979AJ01). Cross sections and angular distributions for the reaction products of the ${}^3\text{H}(\alpha, p){}^6\text{He}$

reaction were measured at $E_\alpha = 27.2$ MeV (1992GO21). A potential description of ${}^3\text{H} + {}^4\text{He}$ elastic scattering is discussed in (1993DU09).

6. ${}^4\text{He}(\alpha, 2p){}^6\text{He}$ $Q_m = -27.322$

Total cross sections for the production of ${}^6\text{He}$ have been measured (2001AU06) at $E_\alpha = 159, 280$ and 620 MeV in a study of cosmic ray nucleosynthesis. The resulting cross sections decrease rapidly with energy.

7. ${}^4\text{He}({}^6\text{He}, {}^6\text{He}){}^4\text{He}$ $E_b = 7.412$

Differential cross sections were measured at $E({}^6\text{He}) = 151$ MeV. DWBA analysis suggests a spectroscopic factor of ≈ 1 for the di-neutron cluster. (1998TE1D, 1998TE03). Measurements at $E_{\text{cm}} = 11.6$ and 15.9 MeV (1999RA15) also show evidence for the $2n$ transfer process in the elastic scattering. However, a couple-discretized-continuum channel analysis discussed in (2000RU03) suggests a smaller $2n$ transfer process than commonly assumed (2001TE03). See also the analyses and calculations of (1998GO1J, 1999OG06, 1999OG09). A microscopic multicluster model description of the elastic scattering process is discussed in (1999FU03).

8. ${}^6\text{He}(p, p){}^6\text{He}$ $E_b = 9.975$

See reaction 2 for experimental information on the ${}^6\text{He} + {}^1\text{H}$ system.

Calculations of the elastic scattering of protons from ${}^6\text{He}$ at $E_p \geq 100$ MeV are described in (1992GA27). A folding model with target densities which reproduce the r.m.s. radii and a range of electroweak data was used.

A calculation of the expansion of the Glauber amplitude described in (1999AB37) found that a ${}^6\text{He}$ matter radius constant with the analysis is 2.51 fm. Finite-range coupled channel calculations have been performed below the ${}^6\text{He}$ three-body breakup threshold (2000TI02). A theoretical study (2000WE03) with four differential nuclear structure models concluded that elastic scattering at < 100 MeV/ A does not provide good constraints on the structure of the ${}^6\text{He}$ ground state. First order optical potentials were studied for $20\text{--}40$ MeV scattering by (2000DE43). A microscopic multicluster calculation of $\sigma(\theta)$ and $\sigma(E)$ for $E_{\text{cm}} = 0\text{--}5$ MeV is reported in (2001AR05).

9. ${}^6\text{Li}(e, \pi^+){}^6\text{He}$ $Q_m = -143.078$

(1986SH14) report breaks in (e, π^+) spectra at $E_e = 202$ MeV corresponding to $E_x = 7, 9, 12, 13.6, 17.7$ and 24.0 MeV. Using the shape of the virtual photon spectrum results in groups with angular distributions that suggest that the states at $13.6, 17.7$ and 24.0 MeV are spin-dipole isovector states [$J^\pi = 1^-, 2^-$]. See also (1990SH11). For the earlier work see (1984AJ01). [Note: The states reported here at $7, 9$ and 12 MeV are inconsistent with the work reported in reactions $12, 13, 22$ and 23 , and with the work on the analog region in ${}^6\text{Be}$].

$$10. \text{ (a) } {}^6\text{Li}(\pi^-, \gamma){}^6\text{He} \quad Q_m = 136.062$$

$$\text{ (b) } {}^6\text{Li}(\pi^-, \pi^0){}^6\text{He} \quad Q_m = 1.086$$

The excitation of ${}^6\text{He}^*(0, 1.8)$ and possibly of (broad) states at $E_x = 15.6 \pm 0.5, 23.2 \pm 0.7$ and 29.7 ± 1.3 MeV has been reported: see (1979AJ01). A study of capture branching ratios to ${}^6\text{He}^*(0, 1.8)$ was reported in (1986PE05). For reaction (b) see (1984AJ01).

$$11. {}^6\text{Li}(n, p){}^6\text{He} \quad Q_m = -2.725$$

Angular distributions of the ground state proton group, p_0 have been reported at $E_n = 4.7$ to 6.8 MeV, at 14 MeV and at 59.6 MeV [see (1979AJ01, 1984AJ01)] and at 118 MeV (1987PO18, 1988HA2C, 1988WA24). At $E_n = 59.6$ MeV broad structures in the spectra are ascribed to states at $E_x = 15.5 \pm 0.5$ and 25 ± 1 MeV with $\Gamma = 4 \pm 1.5$ and 8 ± 2 MeV (1983BR32, 1984BR03) [see for discussions of the GDR strength]. The ground state reaction has also been studied at $E_n = 198$ MeV (1988JA01). Proton spectra were measured at $E_n = 118$ MeV by (1998HA24).

An angular distribution of the proton group corresponding to population of the $E_x = 1.8$ MeV $J^\pi = 2^+$ state in ${}^6\text{He}$ was also reported (1988WA24). See also (1989WA1F). Angular distributions were measured for p_0 at $E_n = 280$ MeV in tests of isospin symmetry in $(n, p), (p, p')$ and (p, n) reactions populating the $T = 1$ isospin triads in $A = 6$ nuclei (1990MI10). Cross sections for $\theta_{\text{lab}} = 1^\circ - 10^\circ$ for $E_n = 60 - 260$ MeV were measured to obtain the energy dependence of the Gamow-Teller strength (1991SOZZ, 1992SO02).

Several theoretical studies have been reported since the previous review. A dynamical multi-cluster model was used to generate transition densities for ${}^6\text{He}$ and ${}^6\text{Li}$ (1991DA08). A microscopic calculation in the framework of the $\alpha + 2N$ model (1993SH1G) reproduced energy spectra and cross sections reliably. Predictions for the structure of a second $2^{(+)}$ resonance in the ${}^6\text{He}$ continuum were made with a $\alpha + N + N$ cluster model (1997DA01). Halo excitation of ${}^6\text{He}$ in ${}^6\text{Li}(n, p){}^6\text{He}$ was studied using four-body distorted wave theory (1997ER05); see also (1997VA06). The status of experimental and theoretical research on nuclei featuring a two-particle halo is reviewed in (1996DA31).

$$12. {}^6\text{Li}(d, 2p){}^6\text{He} \quad Q_m = -4.950$$

The previous review (1988AJ01) notes that at $E_d = 55$ MeV, ${}^6\text{He}^*(0, 1.8)$ [the latter weak] are populated: no other states are observed with $E_x \leq 25$ MeV [see (1984AJ01)]. More recently cross sections at 0° were measured at $E_d = 260$ MeV (1993OH01) and at $E_d = 125.2$ MeV (1995XU02). In both studies the cross section for (d, ${}^2\text{He}$) showed a linear relationship with Gamow-Teller strength from β decay or (p, n) reactions.

$$13. {}^6\text{Li}(t, {}^3\text{He}){}^6\text{He} \quad Q_m = -3.489$$

The ground-state angular distribution has been studied at $E_t = 17$ MeV. At $E_t = 22$ MeV only ${}^6\text{He}^*(0, 1.8)$ are populated for $E_x \leq 8.5$ MeV: see (1979AJ01). Differential cross sections for the transition to ${}^6\text{He}^*(1.8)$ are reported at $E({}^6\text{Li}) = 65$ MeV (1987AL23). In a more recent experiment at $E_t = 336$ MeV reported in (2000NA35), the ${}^6\text{He}$ ground and 1.8 MeV states were populated. In addition, a broad asymmetric structure around $E_x \approx 5$ MeV was observed with an angular distribution which exhibited $\Delta L = 1$ dominance. Another structure at $E_x \approx 14.6$ MeV was observed with the angular distribution indicating $\Delta L = 1$.

$$14. {}^6\text{Li}({}^6\text{Li}, {}^6\text{Be}){}^6\text{He} \quad Q_m = -7.796$$

Angular distributions have been studied for $E({}^6\text{Li}) = 32$ and 36 MeV for the transitions to ${}^6\text{He}_{\text{g.s.}}$, ${}^6\text{Be}_{\text{g.s.}}$ and, in inelastic scattering of ${}^6\text{Li}$ [see ${}^6\text{Li}$], to the analog state ${}^6\text{Li}^*(3.56)$: for a discussion of these see the references quoted in (1979AJ01).

$$15. {}^6\text{Li}({}^7\text{Li}, {}^7\text{Be}){}^6\text{He} \quad Q_m = -4.370$$

Measurements of differential cross sections at $E({}^7\text{Li}) = 82$ MeV are reported in (1992GLZX, 1993GLZZ, 1994SAZZ) and at $E({}^7\text{Li}) = 78$ MeV in (1993SA35, 1994RUZZ). The ${}^6\text{He}$ levels at $E_x = 0$ $J^\pi = 0^+$ and $E_x = 1.80$ $J^\pi = 2^+$ were identified. A maximum at $E_x \approx 6$ MeV is interpreted as consistent with a soft-dipole response expected in neutron-halo nuclei. A study (1996JA11, 1999AN13) at $E({}^7\text{Li}) = 350$ MeV utilized magnetic analysis to observe transitions to the $J^\pi = 0^+$ ground state, and the $J^\pi = 2^+$ state at $E_x = 1.8$ MeV, as well as pronounced resonances at ≈ 5.6 MeV, ≈ 14.6 MeV and ≈ 23.3 MeV (1996JA11). See Table 6.3. In experiments at $E = 65$ MeV/A with this reaction, isovector spin-flip and spin non-flip resonances were deduced (1998NAZP, 1998NAZR). See also the more recent measurements described in (2000NA22) and (2001NA18).

A theoretical study of ${}^6\text{He}$ structure with an extended microscopic three-cluster model is described in (1999AR08).

Table 6.3: Levels in ${}^6\text{He}$ from ${}^6\text{Li}({}^7\text{Li}, {}^7\text{Be}){}^6\text{He}$ ^a

E_x (MeV)	J^π	Γ (MeV)	$d\sigma/d\Omega$ ^b (mb/sr)	G ^c
g.s.	0^+		0.72 ± 0.08	0.46 ± 0.05
1.92 ± 0.17	2^+		0.25 ± 0.04	0.40 ± 0.10
5.6 ± 0.3	$(2^+, 1^-, 0^+)$ ^d	12.1 ± 1.1	4.56 ± 0.48	0.39 ± 0.04
14.6 ± 0.7	$(1, 2)^-$	7.4 ± 1.0	2.11 ± 0.23	0.43 ± 0.06
23.3 ± 1.0		14.8 ± 2.3	1.75 ± 0.19	0.47 ± 0.07

^a (1996JA11). $E({}^7\text{Li}) = 350$ MeV.

^b $\theta_{\text{cm}} = 4.5^\circ$.

^c Averaged spin-flip signatures $G = Y_{\text{coinc}}/Y_{\text{singles}}$.

^d (1999AN13) and J. Jänecke, private communication.

$$16. \text{ (a) } {}^7\text{Li}(\gamma, p){}^6\text{He} \quad Q_m = -9.975$$

$$\text{ (b) } {}^7\text{Li}(e, ep){}^6\text{He} \quad Q_m = -9.975$$

At $E_\gamma = 60$ MeV, the proton spectrum shows two prominent peaks attributed to ${}^6\text{He}^*(0 + 1.8, 18 \pm 3)$: see (1979AJ01). Reactions (a) and (b) have been studied by (1985SE17). See also ${}^7\text{Li}$, (1984AJ01) and (1986BA2G). An analysis of the available experimental data on ${}^7\text{Li}$ photodisintegration at energies up to $E_\gamma = 50$ MeV is presented in (1990VAZM, 1990VA16). See also the discussion of reactions involving scattering of polarized electrons from polarized targets (1993CA11). In more recent work a broad excited state was observed (2001BO38) in ${}^6\text{He}$ with energy $E_x = 5 \pm 1$ MeV and width $\Gamma = 3 \pm 1$ MeV. In experiments with reaction (b) momentum distributions from transitions to the ${}^6\text{He}$ ground and first excited states were measured by (1999LA13, 2000LA17). The deduced spectroscopic factor for both reactions is 0.58 ± 0.05 in agreement with variational Monte Carlo calculations.

$$17. {}^7\text{Li}(\pi^-, {}^6\text{He})n \quad Q_m = 128.812$$

The results of measurements of inclusive spectra made with π^- mesons with momentum 90 MeV/c are presented in (1993AM09). The yield of one-neutron emission was found to be $Y = (1.1 \pm 0.2) \times 10^{-3}$ per stopped π^- .

$$18. {}^7\text{Li}(\pi^-, \pi^-p){}^6\text{He} \quad Q_m = -9.975$$

Pion and proton spectra were measured at 0.7, 0.9, 1.25 GeV/c by (2000AB25). Fermi-momentum distributions were deduced.

19. ${}^7\text{Li}(n, d){}^6\text{He}$ $Q_m = -7.751$

At $E_n = 60$ MeV, the deuteron spectrum shows two prominent peaks attributed to states centered at $E_x = 13.6, 15.4$ and 17.7 MeV (± 0.5 MeV) and a possible state or states (populated with an l_p transfer ≥ 2) at $E_x = 23.7$ MeV. DWBA analyses of the d_0 and d_1 groups are consistent with $l_p = 1$ and $S(1p_{3/2}) = 0.62$ for ${}^6\text{He}_{\text{g.s.}}$ and to $S(1p_{3/2}) = 0.37, S(1p_{1/2}) = 0.32$ for ${}^6\text{He}^*(1.8)$ (1977BR17): see (1979AJ01). Measurements of the cross section as a function of energy for $E_x = 10\text{--}30$ MeV were reported in (1989CO22). See also the measurements at $E_n = 14.1$ MeV (1989SHZS).

20. ${}^7\text{Li}(p, 2p){}^6\text{He}$ $Q_m = -9.975$

From measurements at $E_p = 1$ GeV (1985BE30, 1985DO16), the separation energy between 6–7 MeV broad $1p_{3/2}$ and $1s_{1/2}$ peaks is reported to be 14.1 ± 0.7 MeV. See also (1983GO06) and (1979AJ01). Differential cross section measurements at $E_p = 70$ MeV are reported in (1988PA26, 1998SH33, 2001SH03). Contributions from $1p$ and $1s$ nucleons in ${}^7\text{Li}$ were distinguished. Proton spectra measurements for $E_p = 1$ GeV were reported by (2000MI17, 2001MI07). Effective proton polarizations were deduced. See also the review of experimental and theoretical nucleon and cluster knockout reactions in light nuclei presented in (1987VD1A).

21. ${}^7\text{Li}(d, {}^3\text{He}){}^6\text{He}$ $Q_m = -4.482$

As summarized in the previous review (1988AJ01), angular distributions of the ${}^3\text{He}$ ions to ${}^6\text{He}^*(0, 1.8)$ have been measured at $E_d = 14.4$ and 22 MeV: they have an $l_p = 1$ character and therefore these two states have $J^\pi = (0\text{--}3)^+$. There is no evidence for any other states of ${}^6\text{He}$ with $E_x < 10.7$ MeV: see (1979AJ01). (1987BO39) [$E_d = 30.7$ MeV] deduce that the branching ratio of ${}^6\text{He}^*(1.8)$ into a dineutron [$n^2: T = 1, S = 0$] and an α -particle is 0.75 ± 0.10 . See also (1985BO55) and (1987DA31). More recently, the energy spectrum of neutrons from the ${}^6\text{He}$ excited state at $E_x = 1.8$ MeV populated in this reaction was measured at $E_d = 23$ MeV (1994BO46).

22. ${}^7\text{Li}(t, \alpha){}^6\text{He}$ $Q_m = 9.838$

As summarized in (1988AJ01), the energy of the first-excited state is 1.797 ± 0.025 MeV, $\Gamma = 113 \pm 20$ keV. ${}^6\text{He}^*(1.80)$ decays into ${}^4\text{He} + 2n$. The branching ratio $\Gamma_\gamma/\Gamma_\alpha \leq 2 \times 10^{-6}$: for $\Gamma_{\text{cm}} = 113 \pm 20$ keV, $\Gamma_\gamma \leq 0.23$ eV. Angular distributions of the α_0 and α_1 groups have been measured at $E_t = 13$ and 22 MeV. No other α -groups are reported corresponding to ${}^6\text{He}$ states with $E_x < 24$ MeV (region between $E_x \approx 13$ and 16 MeV was obscured by the presence of breakup α -particles): see (1979AJ01). Angular distributions were reported at $E_t = 0.151$ and 0.272 MeV (1987AB09; α_0, α_1) and at $E({}^7\text{Li}) = 31$ MeV (1987AL23; to ${}^6\text{He}^*(0, 1.8, 13.6)$).

In more recent work, differential cross sections were measured at $E_t = 38$ MeV (1992CL04). DWBA calculations are presented and spectroscopic factors are deduced.

The resonance theory of threshold phenomena was used to analyze differential cross sections for ${}^7\text{Li}(t, \alpha){}^6\text{He}^*(1.8)$ for $\theta < 90^\circ$ at $E_t = 80$ – 500 keV in a study of ${}^{10}\text{Be}$ levels (1991LA1D).

$$23. {}^7\text{Li}({}^3\text{He}, \text{p}^3\text{He}){}^6\text{He} \quad Q_m = -9.975$$

At $E({}^3\text{He}) = 120$ MeV the missing mass spectra show ${}^6\text{He}^*(0, 1.8)$ and a strong, broad peak corresponding to ${}^6\text{He}^*(16)$ [possibly due to unresolved states]. There is no indication of a state near 23.7 MeV but there is some evidence of structures at $E_x = 32.0$ and 35.7 MeV, with $\Gamma \leq 2$ MeV (1985FR01).

$$24. \text{(a) } {}^7\text{Li}({}^6\text{Li}, {}^7\text{Be}){}^6\text{He} \quad Q_m = -4.370$$

$$\text{(b) } {}^7\text{Li}({}^7\text{Li}, {}^8\text{Be}){}^6\text{He} \quad Q_m = 7.280$$

In reaction (a) at $E({}^6\text{Li}) = 93$ MeV a broad peak ($\Gamma = 5.5$ MeV) was reported at $E_x = 14$ MeV. A second structure may also be present at 15.5 MeV (1987GLZW, 1988BUZH). ${}^6\text{He}^*(0, 1.8)$ are also populated (1988BUZH). For reaction (b) see ${}^8\text{Be}$ in (1988AJ01). See also ${}^7\text{Be}$, (1984AJ01) and (1988BU1Q, 1984BA53), and see (1996SO17) which involves ${}^{10}\text{Be}$ excited states. Measurements of differential cross sections at $E({}^7\text{Li}) = 22$ MeV were reported in (1988BO18).

$$25. {}^9\text{Be}(\gamma, {}^3\text{He}){}^6\text{He} \quad Q_m = -21.178$$

Measurements of ground-state cross sections and angular distributions are reported in (1999SH05). See (1999ZHZN) for a compilation and evaluation of cross section data for $E_\alpha \leq 30$ MeV.

$$26. {}^9\text{Be}(n, \alpha){}^6\text{He} \quad Q_m = -0.600$$

Angular distributions have been reported for $E_n = 12.2$ to 18.0 MeV (α_0, α_1). No other states are observed with $E_x \leq 7$ MeV: see (1979AJ01). For a study of possible dineutron breakup of ${}^6\text{He}^*(1.8)$ see (1983OT02). An analysis of the alpha and neutron spectra observed in this reaction for $E_n \approx 14$ MeV is presented in (1988FE06). See also ${}^{10}\text{Be}$ in (1988AJ01) and (1983SH1J).

27. ${}^9\text{Be}({}^6\text{He}, {}^6\text{He}){}^9\text{Be}$

$$E_b = 19.069$$

Elastic scattering measurements for $E({}^6\text{He}) = 8.8$ – 9.3 MeV were reported in (1991SM01). The data are well reproduced with calculations using ${}^6\text{Li}$ or ${}^7\text{Li}$ optical model parameters. See also ${}^9\text{Be}$ in (1988AJ01).

28. ${}^9\text{Be}({}^6\text{Li}, {}^9\text{B}){}^6\text{He}$

$$Q_m = -4.576$$

Differential cross sections were measured at $E({}^6\text{Li}) = 34, 62$ MeV, and spectroscopic factors were deduced (1985CO09). Vector and tensor analyzing powers were measured for detection of the ${}^6\text{He}$ nuclei at $\theta_{\text{cm}} = 14^\circ$ – 80° at $E({}^6\text{Li}) = 32$ MeV (1993RE04). See ${}^9\text{B}$ in (1988AJ01).

29. ${}^9\text{Be}({}^7\text{Li}, {}^6\text{He}){}^{10}\text{B}$

$$Q_m = -3.390$$

This reaction has been used as a source of ${}^6\text{He}$ beams for elastic scattering experiments at $E({}^6\text{He}) = 8.8$ – 9.3 MeV (1991SM01) and at $E({}^6\text{He}) = 10.2$ MeV (1995WA01).

30. ${}^9\text{Be}({}^9\text{Be}, {}^6\text{He}){}^{12}\text{C}$

$$Q_m = 5.101$$

Angular distributions were measured at $E({}^9\text{Be}) = 40$ MeV (1992CO05). See ${}^9\text{Be}$ in (1988AJ01) and ${}^{12}\text{C}$ in (1990AJ01).

31. ${}^{11}\text{B}({}^7\text{Li}, {}^{12}\text{C}){}^6\text{He}$

$$Q_m = 5.982$$

At $E({}^{11}\text{B}) = 88$ MeV the population of the ground state and the first-excited state at $E_x = 1.8 \pm 0.3$ MeV ($\Gamma \leq 0.2$ MeV) is reported (1987BEYI). See also (1988BEYJ).

32. ${}^{12}\text{C}(\mu^+, {}^6\text{He})X$

Measurements of the energy dependence at $E = 100, 190$ GeV were reported by (2000HA33).

33. $^{12}\text{C}(^6\text{He}, n)\text{X}$

Peripheral fragmentation of ^6He at 240 MeV/A was studied (1997CH24, 1997CH47, 1998AL10) in a kinematically complete experiment. It was found that one-neutron stripping to ^5He is the dominant mechanism. A continuation of the analysis described in (2000AL04) indicates excitation of the ^6He first 2^+ state and associates it with E1 dipole oscillation. See also (1993FE02). Model calculations are discussed in (1998BE09, 1998GA37).

34. $^{12}\text{C}(^6\text{He}, \alpha)\text{X}$

Measurements at 240 MeV/A are described in (1998AL10, 1998AN02, 1999AU01, 2000AL04). Fragmentation cross sections of ^6He were analyzed in the Glauber theory to investigate the importance of neutron correlation (1994SU02). Fragmentation reaction data and beta-delayed particle emission data are reproduced successfully. Detailed structure is described with a multicluster model and halo-like structure is discussed in (1995SU13). See also (1998BE09, 1998GA37).

35. $^{12}\text{C}(^6\text{He}, ^6\text{He})^{12}\text{C}$

$$E_b = 18.376$$

Elastic and quasielastic scattering of ^6He on ^{12}C was studied at $E(^6\text{He}) = 10.2$ MeV (1995WA01). See also (1995PE1D). Measurements of cross sections were made at 41.6 MeV/A (1996AL11). The results were successfully analyzed within a 4-body ($\alpha + n + n + ^{12}\text{C}$) eikonal scattering model.

Potential parameters were deduced and differential cross sections were calculated for ^6He scattering at 50 and 100 MeV/A (1993GO06). The possibility of studying the structure of the neutron halo in ^6He elastic rainbow scattering is discussed. See also (1989SI02, 1992CL04, 1993FE02, 1995GA24). Calculations of cross sections at $E = 20\text{--}60$ MeV/A were reported in (2000BO45). Proton, neutron and matter r.m.s. distributions were also calculated.

36. $^{208}\text{Pb}(^6\text{He}, 2n\alpha)\text{X}$

Measurements and analyses of a three-body breakup experiment at 240 MeV/A are described in (1999AU01, 2000AL04). Two-neutron interferometry measurements at 50 MeV/A are discussed in (2000MA12).

⁶Li
(Figs. 5 and 7)

GENERAL: References to articles on general properties of ⁶Li published since the previous review (1988AJ01) are grouped into categories and listed, along with brief descriptions of each item, in the General Tables for ⁶Li located on our website at (www.tunl.duke.edu/NuclData/General_Tables/6li.shtml).

Ground State Properties:

$$\begin{aligned}\mu &= +0.8220473(6) \text{ nm}, +0.8220567(3) \text{ nm: see (1989RA17),} \\ Q &= -0.818(17) \text{ mb (1998CE04).}\end{aligned}$$

The interaction nuclear radius of ⁶Li is 2.09 ± 0.02 fm (1985TA18). These authors have also derived nuclear matter, charge and neutron r.m.s. radii.

Quadrupole moment: The tiny quadrupole moment of ⁶Li poses a difficult task for theoretical calculations. Except for a phenomenological (1985ME02), a microscopic cluster (1986ME13), and a Greens-Function Monte-Carlo (1997PU03) calculation, the models fail even to predict the sign. See the discussion of three-body models in (1993SC30). In (1991UN02), this failure of the three-body models is blamed on the missing antisymmetrization of the valence nucleons with the nucleons in the alpha-core. Another microscopic cluster calculation (1992CS04) considers the findings of (1986ME13) to be due to a fortuitous choice of the model space.

*Asymptotic D/S ratio*¹: The ratio of the D- and S-state asymptotic normalization constants, referred to in the literature as η , has been used widely to quantify the properties of the D-state wave function. There is general agreement in the $A = 2-4$ systems between theoretical calculations and empirical determinations of the normalization constants. See (1988WE20, 1990EI01, 1990LE24). The S-state $\alpha + d$ normalization constant for ⁶Li appears to be well determined (1993BL09, 1999GE02), but both the magnitude and sign of η are uncertain.

In a two-body $\alpha + d$ model it was found (1984NI01) that in order to reproduce the experimental quadrupole moment Q , the wave functions must have $\eta < 0$. However, three-body ($\alpha + n + p$) models consistently result in predictions of $\eta > 0$ (1990LE24, 1995KU08). Recent microscopic six-body calculations using realistic NN potentials predict $\eta = -0.07$ (1996FO04).

The asymptotic D/S ratio has been probed empirically by studying scattering processes, transfer reactions, and ⁶Li breakup. These determinations usually rely on an underlying assumption as to the scattering or reaction mechanism. The S- and D-state asymptotic normalization constants were determined in a study of d- α scattering (1978BO43) from which η was found to be $+0.005 \pm 0.014$. Several ⁶Li + ⁵⁸Ni elastic scattering studies (1984NI01, 1995DE06, 1995RU14) have described polarization observables with $\eta \approx -0.01$, while an investigation of the breakup of ⁶Li on ¹H suggests $\eta > 0$ (1992PU03). A study of the ⁶Li(d, α)⁴He reaction (1990SA47) found that η

¹ We are very grateful to K.D. Veal and C.R. Brune for providing these comments on the asymptotic D/S ratio for ⁶Li.

should lie in the range -0.010 to -0.015 . Recently, a phase-shift analysis of ${}^6\vec{\text{Li}} + {}^4\text{He}$ scattering determined $\eta = -0.025 \pm 0.006 \pm 0.010$ (1999GE02) while an analysis of $({}^6\vec{\text{Li}}, d)$ transfer reactions resulted in a near zero value of $\eta = +0.0003 \pm 0.0009$ (1998VE03).

Based on these theoretical and empirical results, we conclude that both the magnitude and sign of η for the ${}^6\text{Li} \rightarrow \alpha + d$ wave function are not well determined. See also (1998VE03, 1999GE02).

Isotopic abundance: $(7.5 \pm 0.2)\%$ (1984DE53). See also (1987LA1J, 1988LA1C).

For estimates of the parity-violating α -decay width of ${}^6\text{Li}^*(3.56) [0^+; T = 1]$ see (1983RO12, 1984BU01, 1986BU07).

1. ${}^1\text{H}({}^6\text{Li}, {}^6\text{Li}){}^1\text{H}$

Differential cross sections were measured at $E = 0.7 \text{ GeV}/A$ by (2000DOZY, 2001EG02). Matter distribution radii and halo features of ${}^6\text{Li}^*(3.56)$ were deduced.

2. ${}^2\text{H}(\alpha, \pi^0){}^6\text{Li}$ $Q_m = -133.503$

Measurements of cross sections at $E_\alpha = 418, 420 \text{ MeV}$ are reported by (2000AN15, 2000AN31). Halo features of ${}^6\text{Li}^*$ were deduced.

- | | | |
|--|------------------|---------------|
| 3. (a) ${}^3\text{He}({}^3\text{H}, \gamma){}^6\text{Li}$ | $Q_m = 15.7947$ | |
| (b) ${}^3\text{He}({}^3\text{H}, n){}^5\text{Li}$ | $Q_m = 10.41$ | $E_b = 15.80$ |
| (c) ${}^3\text{He}({}^3\text{H}, d){}^4\text{He}$ | $Q_m = 14.32037$ | |
| (d) ${}^3\text{He}({}^3\text{H}, {}^3\text{H}){}^3\text{He}$ | | |

Figure 5: Energy levels of ${}^6\text{Li}$. In these diagrams, energy values are plotted vertically in MeV, based on the ground state as zero. Uncertain levels or transitions are indicated by dashed lines; levels which are known to be particularly broad are cross-hatched. Values of total angular momentum J , parity, and isobaric spin T which appear to be reasonably well established are indicated on the levels; less certain assignments are enclosed in parentheses. For reactions in which ${}^6\text{Li}$ is the compound nucleus, some typical thin-target excitation functions are shown schematically, with the yield plotted horizontally and the bombarding energy vertically. Bombarding energies are indicated in laboratory coordinates and plotted to scale in cm coordinates. Excited states of the residual nuclei involved in these reactions have generally not been shown; where transitions to such excited states are known to occur, a brace is sometimes used to suggest reference to another diagram. For reactions in which the present nucleus occurs as a residual product, excitation functions

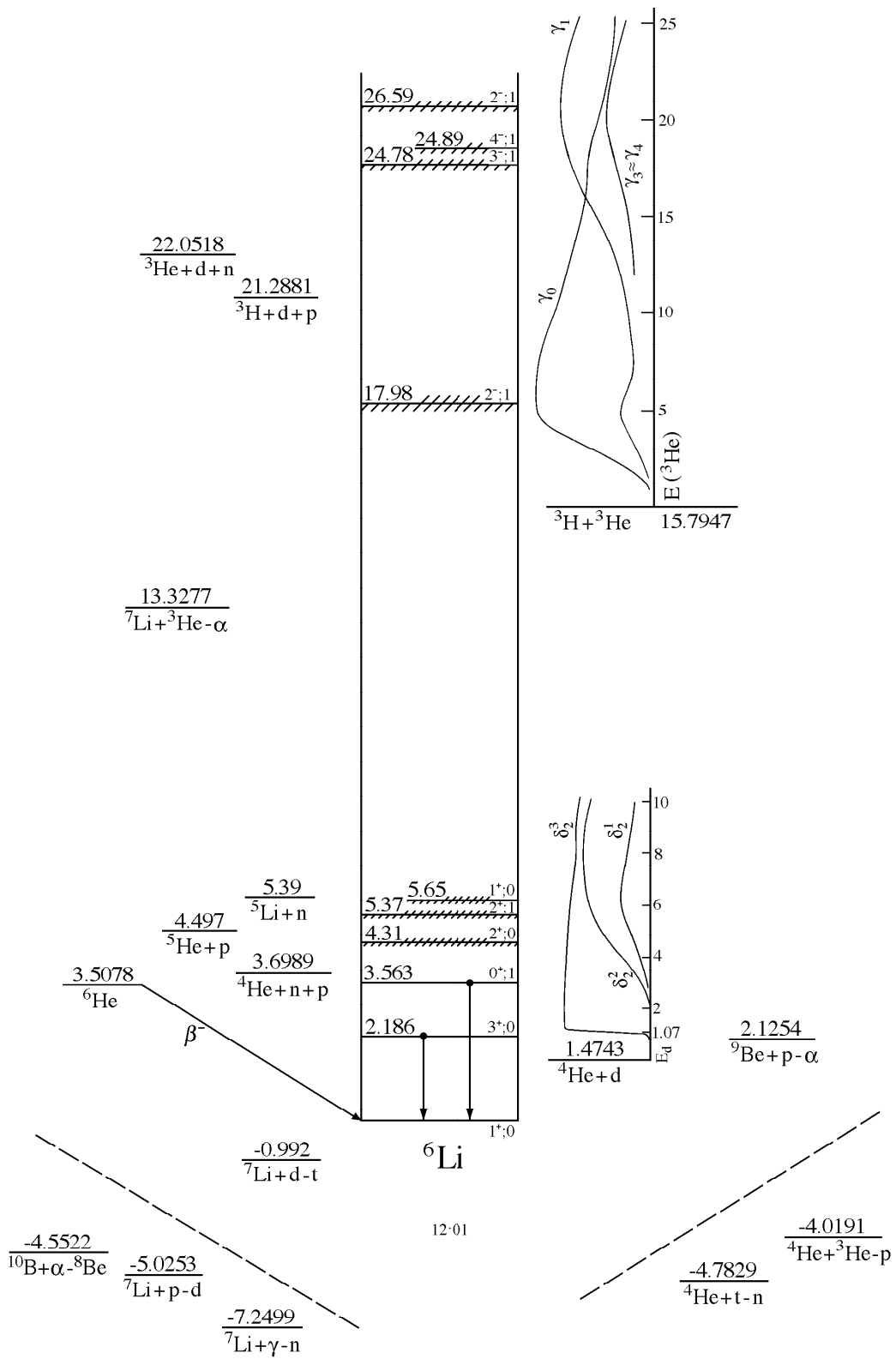

Table 6.4: Energy levels of ${}^6\text{Li}$

E_x (MeV \pm keV) ^a	$J^\pi; T$	Γ_{cm} (MeV) ^a	Decay	Reactions
g.s.	$1^+; 0$		stable	3, 4, 5, 6, 9, 10, 11, 12, 14, 15, 16, 17, 18, 19, 20, 21, 22, 23, 24, 25, 26, 27, 28, 29, 30, 31, 32, 33, 34, 36, 37, 38, 39, 40, 42, 43, 44, 45, 47, 48, 49, 50, 51, 52, 53, 54, 55, 57, 59, 60, 61, 64, 67
2.186 ± 2	$3^+; 0$	0.024 ± 0.002	γ, d, α	3, 4, 5, 8, 9, 10, 17, 18, 19, 20, 21, 23, 24, 25, 26, 27, 29, 30, 33, 34, 36, 37, 38, 39, 42, 44, 45, 46, 47, 48, 49, 55, 57
3.56288 ± 0.10	$0^+; 1$	$(8.2 \pm 0.2) \times 10^{-6}$	γ	3, 5, 12, 15, 17, 18, 20, 21, 22, 23, 25, 34, 37, 38, 39, 42, 44, 67
4.312 ± 22 ^b	$2^+; 0$	1.30 ± 0.10 ^b	γ, d, α	3, 8, 17, 18, 20, 21, 29, 37, 39, 42, 55
5.366 ± 15	$2^+; 1$	0.541 ± 0.020 ^b	γ, n, p, α	3, 17, 20, 37, 38, 39
5.65 ± 50	$1^+; 0$	1.5 ± 0.2	d, α	8, 20, 39, 42
17.985 ± 25 ^{b, c, e}	$2^-; 1$ ^b	3.012 ± 0.007 ^b	$\gamma, t, {}^3\text{He}$	3
24.779 ± 54 ^{b, c, f}	$3^-; 1$ ^b	6.754 ± 0.110 ^b	$\gamma, n, t, {}^3\text{He}$	3, 8
24.890 ± 55 ^{b, c}	$4^-; 1$ ^b	5.316 ± 0.112 ^b	$\gamma, n, t, {}^3\text{He}$	3
26.590 ± 65 ^{b, c, g} d	$2^-; 1$ ^{b, g}	8.684 ± 0.125 ^{b, g}	$\gamma, n, d, t, {}^3\text{He}$	3, 8

^a See also Table 6.12.

^b Newly adopted in this evaluation or revised from the previous evaluation (1988AJ01).

^c See remarks under reaction 3, and see Table 6.5.

^d For possible states at high E_x see reactions 8, 37, 39 and 45 and Table 6.9.

^e $E_x = 17.985 \pm 25$ was previously reported in (1988AJ01) as $E_x = 21.0$ MeV.

^f $E_x = 24.779 \pm 54$ MeV was previously reported as $E_x = 26.6 \pm 0.4$ MeV with $T = 0$ in (1988AJ01). See (1990MO10).

^g (1990MO10).

have not been shown. Further information on the levels illustrated, including a listing of the reactions in which each has been observed, is contained in the master table, entitled “Energy levels of ${}^6\text{Li}$ ”.

In the previous review (1988AJ01), information on radiative capture of ${}^3\text{H}$ on ${}^3\text{He}$ was summarized as follows: “Capture γ -rays (reaction (a)) to the first three states of ${}^6\text{Li}$ [$\gamma_0, \gamma_1, \gamma_2$] have been observed for $E({}^3\text{He}) = 0.5$ to 25.8 MeV, while the yields of γ_3 and γ_4 have been measured for $E({}^3\text{He}) = 12.6$ to 25.8 MeV. The γ_2 excitation function does not show resonance structure. However, the $\gamma_0, \gamma_1, \gamma_3$ and γ_4 yields do show broad maxima at $E({}^3\text{He}) = 5.0 \pm 0.4$ [γ_0, γ_1], 20.6 ± 0.4 [γ_1], ≈ 21 [γ_3] and 21.8 ± 0.8 [γ_4] MeV. The magnitude of the ground-state-capture cross section is well accounted for by a direct-capture model; that for the γ_1 capture indicates a non-direct contribution above $E({}^3\text{He}) = 10$ MeV, interpreted as a resonance due to a state with $E_x = 25 \pm 1$ MeV, $\Gamma_{\text{cm}} = 4$ MeV, $T = 1$ (because the transition is E1, to a $T = 0$ final state) [the E1 radiative width $|M|^2 \geq 5.2/(2J + 1)$ W.u.], $J^\pi = (2, 3, 4)^-$, $\alpha + p + n$ parentage. The γ_4 resonance is interpreted as being due to a broad state at $E_x = 26.6$ MeV with $T = 0$. $J^\pi = 3^-$ is consistent with the measured angular distribution. The ground and first excited state reduced widths for ${}^3\text{He} + t$ parentage, $\theta_0^2 = 0.8 \pm 0.2$ and $\theta_1^2 = 0.6 \pm 0.3$: see (1974AJ01). See also (1985MOZZ, 1986MOZQ, 1987MO11).”

Since the previous review (1988AJ01), a new resonance analysis (1988MO11, 1990HE20, 1990MO10, 1992HE1E) has been applied to the ${}^3\text{He} + {}^3\text{H}$ elastic scattering in odd parity states and to the ${}^3\text{He}({}^3\text{H}, \gamma)$ data. This analysis explains the shape of the capture cross sections and angular distributions in terms of very wide overlapping resonances. See Table 6.5. These correspond to ${}^6\text{Li}$ states at $E_x = 17.985 \pm 0.025$ MeV, $\Gamma_{\text{cm}} = 3.012 \pm 0.007$ MeV, $J^\pi = 2^-$; $E_x = 24.779 \pm 0.054$ MeV, $\Gamma_{\text{cm}} = 6.754 \pm 0.110$ MeV, $J^\pi = 3^-$; $E_x = 24.890 \pm 0.055$ MeV, $\Gamma_{\text{cm}} = 5.316 \pm 0.112$ MeV, $J^\pi = 4^-$; $E_x = 26.590 \pm 0.065$ MeV, $\Gamma_{\text{cm}} = 8.684 \pm 0.125$ MeV, $J^\pi = 2^-$ (all with $S = 1$, $T = 1$). The analysis is compatible with an almost pure ${}^3\text{He}-{}^3\text{H}$ cluster structure of the negative parity unbound ${}^6\text{Li}$ states with $S = 1$, $T = 1$. These results are supported by calculations described in (1995OH03) which utilize a complex-scaled ${}^3\text{He} + t$ resonating group method to calculate the energies and widths of the ${}^6\text{Li}$ ${}^3\text{He} + t$ states. Note, however, that the calculated scattering phase shifts rise only gradually with energy and stay well below 90° . Consequently the stated precision on the extracted level parameters is a point of controversy between the authors of (1990MO10, 1990HE20) and one of the authors [H.M.H.] of this review. The radiative capture reaction as a source of ${}^6\text{Li}$ production in Big Bang nucleosynthesis is discussed in (1990FU1H, 1990MA10, 1997NO04). See also (1995DU12).

The angular distribution and polarization of the neutrons in reaction (b) have been measured at $E({}^3\text{He}) = 2.70$ and 3.55 MeV. The excitation function for $E({}^3\text{He}) = 0.7$ to 3.8 MeV decreases monotonically with energy. The excitation function for n_0 has been measured for $E({}^3\text{He}) = 2$ to 6 MeV and for $E({}^3\text{He}) = 14$ to 26 MeV; evidence for a broad structure at $E({}^3\text{He}) = 20.5 \pm 0.8$ MeV is reported [${}^6\text{Li}^*(26.1)$]: see (1979AJ01).

Angular distributions of deuterons (reaction (c)) have been measured for $E_t = 1.04$ to 3.27 MeV and at $E({}^3\text{He}) = 0.29$ to 32 MeV. Polarization measurements are reported for $E_t = 9.02$ to 17.27 MeV [see (1979AJ01)], as well as at $E({}^3\text{He}) = 18.0$ and 33.0 MeV (1986RA1C). See also (1986KO1K) and (1985CA41). A microscopic calculation for reaction (c) and its inverse with special emphasis on isospin breaking in the analyzing power is described in (1990BR09). See also

Table 6.5: Levels of ${}^6\text{Li}$ from ${}^3\text{He}({}^3\text{H}, {}^3\text{H}){}^3\text{He}$ and ${}^3\text{He}({}^3\text{H}, \gamma_1){}^6\text{Li}^*(2.18)$ ^a

State	$J^\pi; T$	$E_{{}^3\text{He}}$ (MeV)	E_x (MeV)	Γ_{cm} (MeV)
${}^{33}\text{P}_2$	$2^-; 1$	2.190 ± 0.025	17.985 ± 0.025	3.012 ± 0.007
${}^{33}\text{F}_3$	$3^-; 1$	8.984 ± 0.054	24.779 ± 0.054	6.754 ± 0.110
${}^{33}\text{F}_4$	$4^-; 1$	9.095 ± 0.055	24.890 ± 0.055	5.316 ± 0.112
${}^{33}\text{F}_2$	$2^-; 1$	10.795 ± 0.065	26.590 ± 0.065	8.684 ± 0.125

^a From the analysis (1990HE20, 1990MO10) of data from (1968BL10, 1973VE09, 1977VL01).

the calculations of (1990BLZW, 1993DU02, 1993FI06).

Elastic scattering (reaction (d)) angular distributions were measured at $E({}^3\text{He}) = 5.00$ to 32.3 MeV and excitation functions were reported for $E({}^3\text{He}) = 4.3$ to 33.4 MeV see (1979AJ01). At the lower energies the elastic yield is structureless and decreases monotonically with energy. Polarization measurements were reported for $E_t = 9.02$ to 33.3 MeV. A strong change occurs in the analyzing power angular distributions at $E_t = 15$ MeV. See (1988AJ01) for a description of earlier analyses of these data. More recently a new resonance analysis (1990HE20, 1990MO10) of these same data along with ${}^3\text{He}({}^3\text{H}, \gamma)$ data led to the ${}^6\text{Li}$ $S = 1, T = 1$ states discussed above under reaction 3(a). See Table 6.5. A coupled-channels variational model calculation of the ${}^3\text{He}(\text{total})$ cross section for $E_t = 9$ MeV has been reported by (2001TH12).

For other channels see (1984AJ01). See also (1984KR1B). For thermonuclear reaction rates see (1988CA26).

4. (a) ${}^3\text{H}(\alpha, n){}^6\text{Li}$ $Q_m = -4.7829$
 (b) ${}^3\text{H}(\alpha, ad)n$ $Q_m = -6.25725$
 (c) ${}^3\text{H}(\alpha, t){}^3\text{He}$ $Q_m = -20.57762$

${}^6\text{Li}^*(0, 2.19)$ have been populated with reaction (a): see (1974AJ01). See also ${}^7\text{Li}$ (1983CO1E) and (1983FU11). Cross sections for $E_\alpha < 20$ MeV were calculated with a resonating group method by (1991FU02). A kinematically complete experiment on reaction (b) at $E_\alpha = 67.2$ MeV is described in (2000GO35). ${}^6\text{Li}$ excited states at $E_x = 14.5$ and 16.0 MeV with widths ≈ 1 MeV are reported. In a similar experiment (1999GO36) at $E_\alpha = 67.2$ MeV on reaction (c) a ${}^6\text{Li}$ level at $E_x \approx 20\text{--}21$ MeV was reported based on the energy of the final state between ${}^3\text{H}$ and ${}^3\text{He}$.

5. ${}^3\text{He}({}^3\text{He}, \pi^+){}^6\text{Li}$ $Q_m = -123.7941$

Differential cross sections were measured for the transitions to ${}^6\text{Li}^*(0, 2.19)$ for $E({}^3\text{He}) = 350, 420, 500$ and 600 MeV (1983LE26). See also (1984AJ01), (1983BR31, 1983JA13) and (1984GE05). Analyses of data for $E({}^3\text{He}) = 295\text{--}810$ MeV and microscopic reaction model calculations are reported by (1991HA22). See also the calculations of (1999VO01).

6. ${}^4\text{He}(d, \gamma){}^6\text{Li}$ $Q_m = 1.4743$

The previous review (1988AJ01) summarized the information on this reaction as follows: “No resonance has been observed corresponding to formation of ${}^6\text{Li}^*(3.56)$ [0^+ ; $T = 1$]: the parity-forbidden $\Gamma_\alpha \leq 6 \times 10^{-7}$ eV (1984RO04)”. See also (1984BU01, 1986BU07).

“The cross section for the capture cross section has been measured for $E_\alpha = 3$ to 25 MeV by detecting the recoiling ${}^6\text{Li}$ ions: the direct capture is overwhelmingly E2 with a small E1 contribution. The spectroscopic overlap between the ${}^6\text{Li}_{\text{g.s.}}$ and $\alpha + d$ is 0.85 ± 0.04 : see (1984AJ01). See also (1982KI11), (1985CA41, 1986LA22, 1986LA27) and theoretical work presented in (1984AK01, 1985AK1B, 1986AK1C, 1986BA1R).”

Since the previous review (1988AJ01), measurements of the cross section at energies $E_\alpha \approx 2$ MeV corresponding to the 3^+ resonance at $E_x = 2.186$ MeV in ${}^6\text{Li}$ have been reported (1994MO17). Values extracted for the total width Γ and the radiative width Γ_γ confirm the adopted value (1988AJ01). An experimental search for the reaction at $E_{\text{cm}} \approx 53$ keV (1996CE02) gave an upper limit for the S factor of 2×10^{-7} MeV \cdot b at the 90% confidence level. Implications for Big Bang nucleosynthesis of ${}^6\text{Li}$ are discussed. Thermonuclear reaction rates for this reaction calculated from evaluated data are presented in the compilation (1999AN35).

A considerable amount of theoretical work has been devoted to this reaction – much of it related to its importance in astrophysics. A list of references with brief descriptions is provided in Table 6.6.

7. (a) ${}^4\text{He}(d, np){}^4\text{He}$ $Q_m = -2.224$ $E_b = 1.475$
 (b) ${}^4\text{He}(d, t){}^3\text{He}$ $Q_m = -14.320$

Reaction (a) has been studied to $E_\alpha = 165$ MeV and to $E_d = 21.0$ MeV: see (1979AJ01, 1984AJ01). Measurements are also reported at $E_d = 5.4, 6.0$ and 6.8 MeV (1985LU08), 6 to 11 MeV (1985OS02), 10.05 MeV (1983BR23) and 12.0 and 21.0 MeV (1983IS10) and at $E_\alpha = 11.3$ MeV (1987BR07). See also (1986DO1K).

More recently, measurements of the cross section and transverse tensor analyzing power at $E_d = 7$ MeV were made (1988GA14) with kinematic conditions chosen to correspond to production of the singlet deuteron. Coulomb and nuclear field effects in these reactions are discussed in (1987KO1X, 1988KA38). Cross sections and polarization observables from data at $E_d < 12, 17$ MeV are compared with three-body model predictions in (1988SU12).

Table 6.6: ${}^4\text{He}(d, \gamma){}^6\text{Li}$ – Theoretical work

Reference	Description
1989CR01	D-state effects in the ${}^4\text{He}(d, \gamma){}^6\text{Li}$ reaction
1989SC25	The reaction rate at $T = 300$ K for ${}^2\text{H}(\alpha, \gamma){}^6\text{Li}$ and other reactions
1990CR04	Tensor interaction effects in ${}^4\text{He}(d, \gamma){}^6\text{Li}$
1990KRZX	Polarization observables for ${}^4\text{He}(d, \gamma){}^6\text{Li}$ and the D state of ${}^6\text{Li}$
1990SC22	The extended elastic model II applied to ${}^2\text{H}(\alpha, \gamma){}^6\text{Li}$
1991SC23	A simple expression for the cross-section factor in nuclear fusion
1991TY02	Low-energy ${}^2\text{H}(\alpha, \gamma){}^6\text{Li}$ and ${}^{208}\text{Pb}({}^6\text{Li}, d\alpha){}^{208}\text{Pb}$ cross sections
1993JA02	Polarizability and E1 radiation in ${}^4\text{He}(d, \gamma){}^6\text{Li}$
1993MU12	Calculation of the ${}^6\text{Li} \rightarrow \alpha + d$ vertex constant
1994MO17	Direct capture in the 3^+ resonance of ${}^2\text{H}(\alpha, \gamma){}^6\text{Li}$
1995DU12	Cluster model descriptions of ${}^6\text{Li}$ photodisintegration
1995IG06	Analysis of the nuclear astrophysical reaction ${}^4\text{He}(d, \gamma){}^6\text{Li}$
1995MU21	Astrophysical factor for ${}^4\text{He}(d, \gamma){}^6\text{Li}$
1995MU1J	Peripheral astrophysical radiative capture processes, a survey
1995RY01	${}^4\text{He}(d, \gamma){}^6\text{Li}$ capture and the isoscalar E1 multipole
1997NO04	Nuclear reaction rates and primordial ${}^6\text{Li}$
1998KH06	Microscopic study of ${}^2\text{H}(\alpha, \gamma){}^6\text{Li}$ in a multicluster model
2000IG03	Coulomb breakup & astrophys. S -factor of ${}^2\text{H}(\alpha, \alpha)$ at extremely low energies
2001NO01	Six-body calculation of the ${}^2\text{H}(\alpha, \gamma){}^6\text{Li}$ cross section

For reaction (b), measurements of vector and tensor analyzing power at $E_d = 35, 45$ MeV have been reported (1986BR1N, 1986VA23, 1986VUZZ, 1987VU1A). Cross sections and polarization observables were measured at $E_d = 32.1, 35.15, 39.6, 49.7$ MeV to investigate ${}^3\text{H}$ and ${}^3\text{He}$ asymptotic normalization constants (1987VU1B) and charge symmetry breaking (1988VU01). Cross sections and polarization observables measured at $E_{\text{cm}} = 14\text{--}33$ MeV (1989BR23) were compared with microscopic-model predictions in a study of isospin violation. See also (1990BR09). The role of tensor force was explored in (1988BR18).

For earlier work and other breakup channels, see (1988AJ01).

8. ${}^4\text{He}(d, d){}^4\text{He}$

$$E_b = 1.4743$$

Elastic differential cross-section and polarization measurements have been carried out up to $E_\alpha = 166$ MeV and $E_d = 45$ MeV: see (1974AJ01, 1979AJ01, 1984AJ01). Measurements were also reported at $E_d = 0.87$ to 1.43 MeV (1984BA19, 1985BAYZ), at $E_d = 11.9$ MeV (1988EL01), 21 MeV (1986MI1E), 24.0 and 38.2 MeV (1986GR1D), 31.8 to 39.0 MeV (1986KO1M), 40 MeV (1989DE1A), 56 MeV (1985NI01) and at $E_\alpha = 7.0$ GeV/ c (1984SA39). A compilation of data

Table 6.7: Levels of ${}^6\text{Li}$ from ${}^4\text{He}(d, d){}^4\text{He}$ ^a

E_d (MeV)	$J^\pi; T$	E_x (MeV)	Γ_{cm} (MeV)	Γ_d/Γ ^b	γ_d^2 ^c
1.070 ± 0.003	$3^+; 0$	2.187			0.27
4.34 ± 0.04	$2^+; 0$	4.36	1.32 ± 0.04	0.967	0.511
5.7 ± 0.1 ^d	$1^+; 0$	5.3	1.9 ± 0.1	0.74	0.34
(19.3 ± 1.3)	$3^+; 0$	(14.3)	26.7 ± 1.0	0.34	1.69
(21.6 ± 1.1)	$3^+; 0$	(15.8)	17.8 ± 0.8	0.76	0.77
33 ± 2	4^+	23	12 ± 2	0.15	0.14
34 ± 5	3^-	24	16 ± 3	0.30	0.24
39_{-9}^{+3}	2^-	27	22 ± 7	0.43	0.42

^a The data in this table are mostly from the S -matrix analysis of (1983JE03). The results are unique up to $E_d = 15$ MeV. See also Table 6.4 in (1974AJ01), and Tables 6.3 in (1979AJ01) and (1984AJ01).

^b The errors in Γ_d/Γ are typically 0.03.

^c In units of the Wigner limit $\gamma_w^2 = 2.93$ MeV for a radius of 4.0 fm. See (1988AJ01).

^d 6.26 MeV (R -matrix analysis): $E_x = 5.65$ MeV.

for energies $E_d = 1\text{--}56$ MeV is presented in (1987GR08). For a study of the inclusive inelastic scattering at $E_\alpha = 7.0$ GeV/ c see (1987BA13).

Phase-shift analyses, particularly that by (1983JE03) which uses all available differential cross section, vector and tensor analyzing power measurements and $L \leq 5$, in the range $E_d = 3$ to 43 MeV lead to the results displayed in Table 6.7. It is found that the d-wave shifts are split and exhibit resonances at $E_x = 2.19$ (3D_3), 4.7 (3D_2) and 5.65 MeV (3D_1). (1983JE03) suggest very broad G_3 and G_4 resonances at $E_d = (19.3)$ and 33 MeV, a D_3 resonance at 22 MeV and F_3 and F_2 resonances at ≈ 34 and ≈ 39 MeV, corresponding to states which are primarily of $(d + \alpha)$ parentage.

(1985JE04) have investigated the points where $A_{yy} = 1$ and report four such points at $E_d = 4.30$ [$\theta_{\text{cm}} = 120.7^\circ$], 4.57 (58.0°), 11.88 (55.1°) and 36.0 ± 1.0 MeV ($150.1 \pm 0.3^\circ$). [For the latter see also (1986KO1M)]. The correspondence of these polarization maxima to ${}^6\text{Li}$ states is discussed by (1985JE04). For a discussion of the M -matrix see (1988EL01). For work on $(\alpha + d)$ correlations involving ${}^6\text{Li}^*(0, 2.19, 4.31 + 5.65)$ see (1987CH08, 1987CH33, 1987PO03) and (1987FO08).

For additional references to early work see references cited in (1988AJ01).

A considerable body of theoretical work on the ${}^4\text{He} + d$ channel has been done since the previous review (1988AJ01). A list of references with brief descriptions is provided in Table 6.8.

9. (a) ${}^4\text{He}({}^3\text{He}, p){}^6\text{Li}$

$$Q_m = -4.0192$$

Table 6.8: ${}^4\text{He}(d, d){}^4\text{He}$ – Theoretical work

Reference	Description
1988BE58	Polarization phenomena in ${}^4\text{He}(d, d)$ at intermediate energies
1988KA25	Convergence features in the pseudostate theory of the $d + \alpha$ system
1988WE20	Manifestations of the D-state in light nuclei
1989ET05	Description of diffraction scattering on nuclei
1989FI1E	Microscopic theory of collective resonances of light nuclei
1989KR08	Pade approximation technique for processing scattering data
1990BL13	Analysis of higher partial waves in ${}^4\text{He}(d, d)$ in 3-body framework
1990DA1H	Two body phase space in α -d breakup at 40 MeV
1990GU23	D-wave effect in α -d elastic scattering at intermediate energies
1990HO1R	Microscopic study of clustering phenomena
1990HU09	A geometric model for nucleus-nucleus scattering at high energies
1990KU06	Reconstruction of interaction potential from scattering data
1990KU16	Padé-approximation techniques for processing scattering data
1990LI11	Further study of α elastic scattering on light nuclei
1991BL04	Manifestation of Pauli-forbidden states in ${}^4\text{He}(d, d)$ at low energies
1991KR02	Energy-dependent phase-shift analysis of ${}^4\text{He}(d, d)$ at low energies
1991KU09	d - α scattering in a three-body model
1991KU27	Recovering $\alpha + d$ potential from Faddeev and measured phase shifts
1992ES04	α -d resonances and the low-lying states of ${}^6\text{Li}$
1992FU10	Reaction mechanisms in $A = 6$ with the multiconfiguration RGM
1992KU16	Supersymmetric potentials and the Pauli Principle in ${}^4\text{He}(d, d)$
1992KU1G	Deuteron size effects in d - α scattering
1993BL09	Determination of ${}^6\text{Li} \rightarrow \alpha + d$ vertex constant for d - α phase-shifts
1993FI06	Study of continuous spectrum of ${}^6\text{Li}$ in RGM
1994CS01	Microscopic description of beta-delayed deuteron emission in ${}^6\text{He}$
1995DU12	Cluster model description of photonuclear processes in ${}^6\text{Li}$
1997DU15	Electromagnetic effects in light nuclei and the cluster potential
1997KU14	Reconstruction of analytic S matrix from experimental d - α data
1998DU03	Potential cluster model description of the d - α interaction
1999CO11	An S -matrix inversion technique applied to α -d scattering

$$(b) \text{}^4\text{He}(\text{}^3\text{He}, \text{pd})\text{}^4\text{He} \quad Q_m = -5.49349$$

Angular distributions have been measured at $E(^3\text{He}) = 8$ to 18 MeV and $E_\alpha = 42, 71.7$ and 81.4 MeV: see (1974AJ01). More recently, proton polarization was measured as a function of angle at $E_{\text{cm}} = 12.6$ MeV (1989GR02). At $E_\alpha = 28, 63.7, 71.7$ and 81.4 MeV the α -spectra show that the sequential decay (reaction (b)) involves ${}^6\text{Li}^*(2.19)$ and possibly ${}^5\text{Li}$: see (1979AJ01). See also the recent theoretical work of (1993GO16) and the multiconfiguration RGM calculations of (1995FU16).

$$\begin{aligned} 10. (a) \text{}^4\text{He}(\alpha, \text{d})\text{}^6\text{Li} & \quad Q_m = -22.3722 \\ (b) \text{}^4\text{He}(\alpha, \text{pn})\text{}^6\text{Li} & \quad Q_m = -24.5968 \\ (c) \text{}^4\text{He}(\alpha, \alpha\text{d})\text{}^2\text{H} & \quad Q_m = -23.84653 \end{aligned}$$

Reactions (a) and (b) have been studied to $E_\alpha = 158.2$ MeV [see (1979AJ01, 1984AJ01)] and at 198.4 MeV (1985WO11). The dependence of the cross section on energy shows that the $\alpha + \alpha$ process does not contribute significantly to ${}^6\text{Li}$ (and ${}^7\text{Li}$) synthesis above $E_\alpha = 250$ MeV (1985WO11) [and see for additional comments on astrophysical problems]. A more recent measurement of the cross section for reaction (b) (2001AU06, 2001ME13) at $E_\alpha = 159.3, 279.6$ and 619.8 MeV found cross sections which differ significantly from tabulated values commonly used in cosmic-ray production calculations and lead to lower predicted production of ${}^6\text{Li}$. For reaction (c) [and excited states of ${}^4\text{He}$] see (1984AJ01): ${}^6\text{Li}^*(2.19)$ is involved in the process.

$$11. \text{}^6\text{He}(\beta^-)\text{}^6\text{Li} \quad Q_m = 3.508$$

See ${}^6\text{He}$, reaction 1.

$$\begin{aligned} 12. (a) \text{}^6\text{He}(\text{p}, \text{n})\text{}^6\text{Li} & \quad Q_m = 2.7254 \\ (b) \text{}^6\text{He}(\text{p}, \text{p})\text{}^6\text{He} & \end{aligned}$$

The (p, n) reaction has been studied in inverse kinematics by ${}^1\text{H}({}^6\text{He}, {}^6\text{Li})\text{n}$ experiments with secondary ${}^6\text{He}$ beams. An experiment utilizing a secondary ${}^6\text{He}$ beam with $E({}^6\text{He}) = 42$ MeV/ A was reported by (1995CO05, 1998CO1M, 1998CO19, 1998CO28). The ${}^6\text{Li}$ ground state and $E_x = 3.56$ MeV state were observed. Angular distributions were reported and the ratio of the cross section for the Gamow-Teller transition to the ground state and the Fermi transition to the isobaric analog state was measured. The reaction was also studied at $E/A = 93$ MeV (1996BR30). The 0° ground state cross section was measured to be $\frac{d\sigma}{d\Omega} = 43 \pm 16$ mb/sr. The ratio of Gamow-Teller to Fermi strength was found to be $(87 \pm 6)\%$ of that expected from p, n systematics and

beta decay. Differential cross sections at $E/A = 41.6\text{--}68$ MeV were measured by (1997CO04) to study the effects of halo structure. Measurements on reactions (a) and (b) utilizing a secondary ${}^6\text{He}$ beam at 36 MeV/A are reported by (2001DE19).

The status of theoretical and experimental research on nuclei featuring a two-particle halo was reviewed in (1996DA31).

$$13. {}^6\text{Li}^*(0^+; 1) \rightarrow \alpha + \text{d} \quad Q_m = 2.0886$$

A theoretical study in a microscopic three-cluster model of the parity-violating $\alpha + \text{d}$ decay of the lowest 0^+ state in ${}^6\text{Li}$ ($E_x = 3.5629$ MeV) is described in (1996CS03). A phase shift analysis of ${}^4\text{He} + \text{d}$ was used in a determination of the vertex constant for the ${}^6\text{Li}(1^+; 0)_{\text{g.s.}} \rightarrow \alpha + \text{d}$ virtual decay by (1992BLZX, 1993BL09, 1997KU14). See also (1990RY07, 1991KR02, 1993BO38).

$$\begin{aligned} 14. \text{(a) } & {}^6\text{Li}(\gamma, \text{n}){}^5\text{Li} & Q_m &= -5.389 \\ \text{(b) } & {}^6\text{Li}(\gamma, \text{p}){}^5\text{He} & Q_m &= -4.497 \\ \text{(c) } & {}^6\text{Li}(\gamma, \text{d}){}^4\text{He} & Q_m &= -1.4743 \\ \text{(d) } & {}^6\text{Li}(\gamma, \text{np}){}^4\text{He} & Q_m &= -3.6989 \\ \text{(e) } & {}^6\text{Li}(\gamma, \text{t}){}^3\text{He} & Q_m &= -15.7947 \end{aligned}$$

The previous review (1988AJ01) summarizes the information on these reactions as follows: “The (γ, n) and (γ, Xn) cross sections increase from threshold to a maximum at $E_\gamma \approx 12$ MeV then decrease to $E_\gamma = 32$ MeV: see (1984AJ01) and (1988DI02). (1984DY01) also report a broad peak at 16 MeV. The cross section for photoproton production (reaction (b)) is generally flat up to 90 MeV. [The previously reported hump at $E_\gamma \approx 16$ MeV is almost certainly due to oxygen contamination: see (1984AJ01).] See also (1988CA11) and ${}^5\text{He}$. The cross section for reaction (c) is $\leq 5 \mu\text{b}$ in the range $E_\gamma = 2.6$ to 17 MeV consistent with the expected inhibition of dipole absorption by isospin selection rules: see (1966LA04). The onset of quasideuteron photodisintegration between 25 and 65 MeV is suggested by the study of (1984WA18; $E_\gamma(\text{bremsstrahlung}) = 67$ MeV). The 90° differential cross section for reaction (e) decreases monotonically for $E_\gamma = 18$ to 70 MeV: reaction (e) contributes $\approx \frac{1}{3}$ of the total cross section for ${}^6\text{Li} + \gamma$, consistent with a ${}^3\text{H} + {}^3\text{He}$ cluster description of ${}^6\text{Li}_{\text{g.s.}}$ with $\theta^2 \approx 0.68$. The agreement with the inverse reaction, ${}^3\text{H}({}^3\text{He}, \gamma)$ [see reaction 3] is good: see (1984AJ01). See also (1986LI1F).”

“The absorption cross section has been studied in the range $E_\gamma \approx 100$ to 340 MeV; it shows a broad bump centered at ≈ 125 MeV and a fairly smooth increase to a maximum at ≈ 320 MeV: see (1984AJ01). For spallation studies see (1974AJ01, 1984AJ01). For pion production see (1986GL07, 1987GL01) and (1984AJ01).”

Since the previous review (1988AJ01) tagged photons were used to study ${}^6\text{Li}(\gamma, \text{p})$ at $\theta_p = 0^\circ$ for $E_\gamma \approx 59$ and 75 MeV. Strong evidence for the photo-deuteron mechanism was found.

Table 6.9: ${}^6\text{Li}(\gamma, X)$ – Theoretical work

Reference	Description
1988DU04	Calculation of the ${}^6\text{Li}(\gamma, d\gamma')$ cross section at $E_\gamma = 2.23$ MeV
1989AR02	Quark degrees of freedom and nuclear photoabsorption
1990BU29	Possibility (?) of observing an isoscalar E1 multipole in ${}^6\text{Li}(\gamma, d)$
1990VA16	Cluster effects in ${}^6\text{Li}$ photodisintegration
1990ZH19	Manifestations of cluster structure in ${}^6\text{Li}(\gamma, d)$
1991BE05	${}^6\text{Li} \rightarrow \alpha + d$ break-up — astrophysical significance
1995DU12	Description of photonuclear processes in ${}^6\text{Li}$

Measurements made for angles between 30° and 150° (1995DI01) showed most of the strength occurring in three-body breakup channels. Studies at these same energies of the (γ, d) and (γ, t) reaction were reported in (1997DI01). See also (1994RY01). Measurements of ${}^6\text{Li}(\gamma, d)$ at $E_\gamma \approx 60$ MeV indicated strict non-violation of the isospin selection rule for E1 absorption.

The (γ, pn) reaction was also studied at $E_\gamma = 55$ – 100 MeV with bremsstrahlung photons and with linearly polarized tagged photons for $E_\gamma = 0.3$ – 0.9 GeV. See also (1990RIZX).

Linearly polarized photons were used to measure the cross section asymmetry in ${}^6\text{Li}(\gamma, t){}^3\text{He}$ up to $E_\gamma \approx 70$ MeV (1989BU10) and differential cross sections up to $E_\gamma \approx 90$ MeV (1993DE07, 1995BU08). Results of a measurement of the absolute total photoabsorption cross section for $E_\gamma = 300$ – 1200 MeV are presented in (1994BI06).

A list of theoretical references relating to ${}^6\text{Li}$ photonuclear reactions with brief descriptions is provided in Table 6.9.

15. ${}^6\text{Li}(\gamma, \gamma){}^6\text{Li}$

The width, Γ_γ , of ${}^6\text{Li}^*(3.56) = 8.1 \pm 0.5$ eV: see (1974AJ01) and Table 6.4 in (1979AJ01); $E_x = 3562.88 \pm 0.10$ keV: see (1984AJ01). See also (1987PI06). The results of an absolute measurement of the total photoabsorption cross section are described in (1994BI06). Photon absorption and photon scattering for light elements is discussed in terms of a collective resonance phenomenon in (1990ZI03).

16. (a) ${}^6\text{Li}(\gamma, \pi^0){}^6\text{Li}$ $Q_m = -134.97660$
 (b) ${}^6\text{Li}(\gamma, \pi^+){}^6\text{He}$ $Q_m = -143.0780$
 (c) ${}^6\text{Li}(\gamma, \pi^-){}^6\text{Be}$ $Q_m = -143.8579$

Measurements of neutral-pion photoproduction yield (reaction (a)) for $E < 10$ MeV above threshold were reported in (1989NA23). The total cross section was measured in the energy region

from the reaction threshold to $E_\gamma \approx 146.5$ MeV (1989GL07) and analyzed in the impulse approximation. The cross section increases monotonically to $\sigma = 6.50 \pm 0.96 \mu\text{b}$ at $E_\gamma = 146.5$ MeV. See also (1986GL07, 1987GL01) and (1984AJ01). An analysis (1991TR1C) of early measurements suggests that anomalously large measured values of the cross section are due to target impurities. The differential cross section at small angles at energies $E \approx 300\text{--}450$ MeV has been measured by (1991BE16). Total and differential cross sections were measured within 23 MeV of threshold with tagged photons by (1999BE14). Differential cross sections for reaction (b) leading to the ${}^6\text{He}$ ground state have been measured at $E_\gamma = 200$ MeV (1991SH02) and analyzed by DWBA. See also the measurements of (1991GA26). The energy distributions of electroproduced π^+ at $E_e \approx 200$ MeV were measured and (γ, π^+) cross sections were deduced (1994SH38). For reaction (c) see (1988KA41, 1991GA26).

Theoretical studies of pion photoproduction include: an impulse-approximation calculation for (γ, π^0) at $E_\gamma = 300$ MeV (1989TR09); an impulse approximation and shell model study of inelastic photoproduction of pions (1991TR02); a DWIA Feynman-diagram production-operator-based calculation of (γ, π^+) at $E_\gamma = 200$ MeV (1990BE49); and multicluster dynamic-model calculation of π^+ photoproduction off ${}^6\text{Li}$ (1995ER1B); and an exclusive (γ, π^+) production calculation for $E_\gamma = 200$ MeV (1995DO24).

17. (a) ${}^6\text{Li}(e, e){}^6\text{Li}$
 (b) ${}^6\text{Li}(e, ep){}^5\text{He}$ $Q_m = -4.497$
 (c) ${}^6\text{Li}(e, ed){}^4\text{He}$ $Q_m = -1.4743$
 (d) ${}^6\text{Li}(e, et){}^3\text{He}$ $Q_m = -15.7947$

The previous review (1988AJ01) summarized the information then available on electron scattering as follows: “The elastic scattering has been studied for $E_e = 85$ to 600 MeV: see (1974AJ01, 1979AJ01, 1984AJ01). The results appear to require that the ground state be viewed as an α -d cluster in which the deuteron cluster is deformed and aligned. The ground-state M1 current density has also been calculated (1982BE11). A model-independent analysis of the elastic scattering yields $r_{\text{T.m.s.}} = 2.51 \pm 0.10$ fm. See also the discussion in (1984DO20).”

“Table 6.10 summarizes the results obtained in the inelastic scattering of electrons. Form factors have been measured for ${}^6\text{Li}^*(2.19, 3.56, 5.37)$ as well as for the $t+{}^3\text{He}$ continuum up to 4 MeV above threshold [no narrow structures corresponding to ${}^6\text{Li}$ states are observed]: see (1984AJ01)”. In more recent work, nucleon spin structure functions were extracted from measurements of deep inelastic scattering on polarized targets by (1999RO13).

For reaction (b) see ${}^5\text{He}$ and (1987VA08) and (1987VA1N). Angular distributions for the d_0 group in the (e, d_0) reaction have been measured for $E_x = 10$ to 28 MeV. The deduced E1 and E2 components of the (γ, d_0) cross section show no structure. The E1 strength implies non-negligible isospin mixing in this energy region (1986TA06). Triple differential cross sections were measured for $E_x = 27\text{--}49$ MeV in a search for GDR evidence (1999HO02). At $E_e = 480$ MeV (reaction (c)) the α -d momentum distribution in the ground state of ${}^6\text{Li}$ has been studied. The results are well

Table 6.10: Levels of ${}^6\text{Li}$ from ${}^6\text{Li}(e, e')$ and ${}^6\text{Li}(\gamma, \gamma')$ ^a

E_x (MeV)	$J^\pi; T$	Γ_{γ_0} (eV)	Multipolarity
2.183 ± 0.009	$3^+; 0$	$(4.40 \pm 0.34) \times 10^{-4}$ ^b	E2
3.56288 ± 0.00010 ^c	$0^+; 1$	8.19 ± 0.17 ^d	M1
4.27 ± 0.04	$2^+; 0$	$(5.4 \pm 2.8) \times 10^{-3}$	E2
5.379 ± 17 ^{d, e}	$2^+; 1$	0.27 ± 0.05	M1

^a See Tables 6.4 in (1979AJ01, 1984AJ01) for references and for the earlier work.

^b (1969EI06), $B(E2)^\uparrow = 25.6 \pm 2.0 e^2 \cdot \text{fm}^4$. The value given in (1988AJ01) was incorrect. We are grateful to Dr. John Millener for pointing out this error.

^c (1981RO02).

^d Weighted mean of values shown in Table 6.4 in (1979AJ01).

^e $\Gamma = 540 \pm 20$ keV.

accounted for by an α NN model. The α -d probability in the ground state of ${}^6\text{Li}$ is 0.73 [estimated ± 0.1]. The data are consistent with the expected $2S$ character of the α -d relative wave function (1986EN05). See also (1986EV1A). π^0 production involving ${}^6\text{Li}^*(2.19, 3.56, 5.37)$ is reported at $E_e = 500$ MeV (1987NA11).

For the earlier work see (1979AJ01, 1984AJ01) and the references cited in (1988AJ01).

Since the previous review (1988AJ01), experimental results on quasielastic response have been reviewed (1988LO1E). Measurements of the quasielastic scattering cross section for electrons on ${}^6\text{Li}$ are reported at momentum transfer $0.85\text{--}2.3 \text{ fm}^{-1}$ (1988BU25). See also the measurements at $E_e = 80\text{--}680$ MeV by (1989LI09). Cross sections for ${}^6\text{Li}(e, ep)$ were measured in the missing energy region $0 \leq E_m \leq 30$ MeV and in the range $-100 \leq p_m \leq 200$ MeV/ c of missing momentum (1989LA22). The ${}^6\text{Li} \rightarrow p + (n\alpha)$ spectral function was measured (1989LA13). The ratio of transverse and longitudinal response function was investigated in (1990LA06). See also the review (1990DE16) of proton spectral functions and momentum distributions in $(e, e'p)$ experiments and see the report (1990GH1E) on nuclear density dependence of electron proton coupling in ${}^6\text{Li}(e, e'p)$.

Reaction (c) was used (1990JO1D) in a study of correlation functions in ${}^6\text{Li}$. A measurement in parallel kinematics to study the mechanism of the ${}^6\text{Li}(e, e'\alpha){}^2\text{H}$ reaction is reported in (1991MI19, 1994EN04). Cross sections for ${}^6\text{Li}(e, e't){}^3\text{He}$ (reaction (d)) at $E_e = 523$ MeV and the momentum-transfer dependence of the ${}^3\text{H}$ and ${}^3\text{He}$ knockout reaction was measured by (1998CO06).

A list of references to theoretical work related to electron scattering on ${}^6\text{Li}$ is provided, along with brief descriptions, in Table 6.11.

18. (a) ${}^6\text{Li}(\pi^\pm, \pi^\pm){}^6\text{Li}$

(b) ${}^6\text{Li}(\pi^+, \pi^-)$

Table 6.11: ${}^6\text{Li}(e, e){}^6\text{Li}$ – Theoretical work

Reference	Description
1987KR07	EM properties of ${}^6\text{Li}$ in cluster model
1987LE1N	Coincidence reactions and the 3-body structure of ${}^6\text{Li}$
1988AL1J	Second Born approximation correction to ${}^6\text{Li}$ electron scattering
1988ES01	Elastic electromagnetic form factors of ${}^6\text{Li}$ from 3-body models
1989ER07	Exchange and correlation effects in EM structure of ${}^6\text{Li}$
1989ES05	Inelastic ($1^+ \rightarrow 0^+$) EM form factor of ${}^6\text{Li}$ with 3-body models
1989KU21	Correlation and exchange effects in EM form factors
1990BE54	Analysis of ${}^6\text{Li}(e, e'){}^6\text{Li}$ transitions to the low-lying ${}^6\text{Li}$ levels
1990DE1V	NN correlations, evidence from ${}^6\text{Li}(e, e'){}^5\text{He}$
1990KU12	Detailed study of EM structure of ${}^6\text{Li}$ from 3-body model
1990LO14	Cluster-model interpretation of ${}^6\text{Li}(e, e'){}^5\text{He}$
1990LU06	Calculation of the magnetic form factor of ${}^6\text{Li}$
1990RE1I	Parity-invariance violation in ${}^6\text{Li}(e, e'){}^4\text{He}$
1990WA1J	Occupation probabilities of shell-model orbitals
1991LU07	Magnetic form factor of ${}^6\text{Li}$
1991UN02	${}^6\text{Li}$ elastic form factors and antisymmetrization
1992JO02	Two-body correlations in ${}^6\text{Li}$ through the $(e, e'd)$ reaction
1992LO09	Multiquark configuration effect on nuclear charge form factor
1992LOZX	Short-range correlation in the 6-body ${}^6\text{Li}$ wave function
1992RYZY	EM properties of ${}^6\text{Li}$ in multicluster dynamic model
1992ZH18	Calculation of ${}^6\text{Li}(e, ed)$ cross section in $\alpha 2N$ model
1993KU27	Prohibition and suppression of multicluster states by Pauli principle
1993RY01	${}^6\text{Li}$ properties — multicluster dynamic model
1993SC30	Nucleon polarization in 3-body models of polarized Li
1994BO04	Shell model calculation of magnetic electron scattering
1994WE10	${}^6\text{Li}$ inelastic form factors in a cluster model
1995AR10	Halo structure in ${}^6\text{Li } E_x = 3.563 \text{ } 0^+$ state
1995DO23	Phenomenological transition amplitudes in selected p-shell nuclei
1995KU08	Cluster structure of ${}^6\text{Li}$ low-lying states
1995MA59	Finite-size effects in quasi-elastic scattering — Fermi gas model
1998WI10	Quantum Monte Carlo calculations for light nuclei
1998WI28	Microscopic calculation of ${}^6\text{Li}$ elastic & transition form factors
1999GN01	Multicluster calculation of ${}^6\text{Li}(e, e')$ asymmetric & polarization ratios

(c) ${}^6\text{Li}(\pi^-, \pi^+){}^6\text{H}$	$Q_m = -27.77$
(d) ${}^6\text{Li}(\pi^+, \pi^+p){}^5\text{He}$	$Q_m = -4.497$
(e) ${}^6\text{Li}(\pi^+, p){}^5\text{Li}$	$Q_m = 134.96$
(f) ${}^6\text{Li}(\pi^-, p){}^5\text{H}$	$Q_m = 114.2$
(g) ${}^6\text{Li}(\pi^+, 2p){}^4\text{He}$	$Q_m = 136.6536$
(h) ${}^6\text{Li}(\pi^-, 2p)4n$	$Q_m = 106.7933$
(i) ${}^6\text{Li}(\pi^+, \pi^+d){}^4\text{He}$	$Q_m = -1.4743$
(j) ${}^6\text{Li}(\pi^+, pd){}^3\text{He}$	$Q_m = 118.3006$
(k) ${}^6\text{Li}(\pi^+, {}^3\text{He}){}^3\text{He}$	$Q_m = 123.7941$
(l) ${}^6\text{Li}(\pi^-, {}^3\text{He})3n$	$Q_m = 114.5113$

Elastic angular distributions have been measured at $E_{\pi^+} \approx 50$ MeV [see (1984AJ01)] and at $E_{\pi^\pm} = 100, 180$ and 240 MeV (1986AN04; also to ${}^6\text{Li}^*(2.19)$). Differential cross sections are also reported for $E_{\pi^+} = 100$ to 260 MeV to ${}^6\text{Li}^*(0, 2.19, 3.56, 4.25)$. The excitation function for the unnatural-parity transition to ${}^6\text{Li}^*(3.56)$ has an anomalous energy dependence (1984KI16).

A number of experimental studies with polarized targets have been reported for elastic and inelastic ($E_x({}^6\text{Li}) = 2.19$ MeV, $J^\pi = 3^+$) scattering. Measurements of polarization observables are reported at $E_{\pi^+} = 134, 164$ MeV (1989TA21, 1990TA1L, 1991BO1R), $E_{\pi^+} = 160$ – 219 MeV (1991RI01, 1994RI06). Comparison of these data with a coupled channels model is discussed in (1995BO1H). See also the Δ -hole model analysis of (1992JU1B) and the multicluster dynamic model analysis by (1995RY1C). Calculations of cross sections and polarization observables at $E_{\pi^+} = 80$ – 260 MeV are presented in (1988ER06, 1988NA06). A theoretical study in terms of a strong absorption model is described in (1998AH06). Quantum Monte-Carlo calculations of cross sections for $E_\pi = 100$ – 240 MeV are reported in (2001LE01). Transition densities and $B(E2)$ transition strengths were also calculated.

Measurements of pion double-charge exchange cross section (reactions (b) and (c)) at incident pion energies $E_\pi = 180, 240$ MeV are reported in (1989GR06, 1995FO1J). In (1991SE06) it is shown that continuum missing mass spectra from reaction (c) can be explained in terms of the presence of dineutrons in the products of the breakup.

Cross section measurements for reaction (d) at $E_{\pi^+} = 130, 150$ MeV are reported in (1987HU02). For a study of reaction (i) at $E_{\pi^+} = 130$ MeV, see (1987HU13).

Pion absorption followed by nucleon emission (reactions (e), (f), (g), (h), (j), (k), (l)) has been studied in a number of experiments. For reaction (k) see (1983BA26, 1983LO10, 1985MC05, 1986MC11). Measurements have been reported for cross sections for reaction (g) at $E_{\pi^+} = 30, 50, 80, 115$ MeV (1989ROZY); reactions (g) and (h) angular distributions at $E_\pi = 70, 130, 165$ MeV (1989YO05); reactions (g) and (h) angular correlations at $E_\pi = 165$ MeV (1989YO07); cross sections for reaction (g) at $E_{\pi^+} = 115, 140, 165, 190, 220$ MeV (1989ZHZZ); angular distributions for reaction (h) at $E_\pi = 70, 130, 165$ MeV (1989YO03); two-particle coincidences for reactions (g) and (h) at low energies (1991YO1C); cross sections at $E_\pi = 50, 100, 150, 200$

MeV (1990RA05, 1990RA20, 1992RA01, 1992RA11); differential and total cross sections for reaction (g) at $E_{\pi^+} = 100, 165$ MeV (1995PA22, 1996LO04); inclusive spectra of ${}^3\text{He}$ produced in reaction (l) (1992AM1H, 1993AM09); total reaction cross sections for $(\pi^+, X), (\pi^-, X)$ at $E_{\pi} = 42\text{--}65$ MeV (1996SA08). See also the earlier work on reaction (g) at $E_{\pi^+} = 59.4$ MeV (1986RI01), and see the compilation and review of (1992BA57, 1993IN01).

Analysis of particle emission following π^+ absorption on ${}^6\text{Li}$ (1990RA20) has produced evidence for a three-nucleon absorption model. Distorted-wave impulse approximation calculations of cross sections and analyzing powers have been made (1992KH04) for two-nucleon pion absorption on polarized ${}^6\text{Li}$ targets. A model based solely on isospin was used (1993MA14) in a calculation of ratios of pion absorption on three nucleons and agreement with experiment suggest a one-step process.

19. (a) ${}^6\text{Li}(n, n){}^6\text{Li}$	
(b) ${}^6\text{Li}(n, nd){}^4\text{He}$	$Q_m = -1.4743$
(c) ${}^6\text{Li}(n, p){}^6\text{He}$	$Q_m = -2.7254$
(d) ${}^6\text{Li}(n, d){}^5\text{He}$	$Q_m = -2.272$
(e) ${}^6\text{Li}(n, t){}^4\text{He}$	$Q_m = 4.7829$
(f) ${}^6\text{Li}(n, \alpha){}^3\text{H}$	$Q_m = 4.7829$

Angular distributions involving the groups to ${}^6\text{Li}^*(0, 2.19)$ have been reported at $E_n = 1.0$ to 14.6 MeV [see (1984AJ01)], 4.2, 5.4 and 14.2 MeV (1985CH37; n_0, n_1), 7.5 to 14 MeV (1983DA22; n_0), 8.9 MeV (1984FE1A; n_0), 8.0 and 24 MeV (1986HAZR; n_0, n_1), $E_n = 5$ to 17 MeV (1986PF1A; n_0), 11.5, 14.1 and 18 MeV (1998CH33; n_0, n_1), and at 11.5 and 18.0 MeV (1998IB02; n_0, n_1).

An analysis (1988HA25) of (n, n) and (n, n') data at $E_n = 24$ MeV indicated that neutron and proton transition densities were approximately equal ($\rho_n \approx \rho_p$) in ${}^6\text{Li}$. Cross sections and analyzing powers for $E_n = 8\text{--}40$ MeV were analyzed (1989HAZV) with microscopic optical model potentials. Secondary neutron spectra induced by 14.2 MeV neutrons on ${}^6\text{Li}$ were measured by (1993XI04).

An analysis of (n, n') data at $E_n = 7.45\text{--}14$ MeV is discussed in (1990BE54). See also the calculation for elastic coherent and incoherent scattering of thermal neutrons on ${}^6\text{Li}$ (1990GO26) and the multi-cluster dynamic model calculation for ${}^6\text{Li}(n, n)$ at $E_n = 12$ MeV (1992KA06).

Theoretical studies of ${}^6\text{Li}(n, n)$ include multiconfiguration resonating group calculations (1988FU09, 1991FU02), folding model descriptions for $E_n = 25\text{--}50$ MeV (1993PE13), study of antisymmetry in NN potentials (1995CO18), study of optical model potentials for intermediate energies (1996CH33).

For reaction (b) see (1984AJ01, 1985CH37, 1993XI04, 1994EL08).

A number of experiments on the (n, p) charge exchange (reaction (c)) have been reported. They include: measurements of $\sigma(E_p)$ and $\sigma(\theta)$ at $E_n \approx 198$ MeV (1987HE22); $\sigma(\theta, E_p)$ at $E_n \approx 118$ MeV (1987PO18, 1988HA12, 1998HA24); $\sigma(\theta)$ at $E_n = 198$ MeV (1988JA01); $\sigma(\theta)$ to explore

the Gamow-Teller sum rule (1988WA24); $\sigma(\theta)$, $\sigma(E_p)$ at $E_n = 280$ MeV for an isospin symmetry test (1990MI10); $\sigma(\theta, E)$ at $E_n = 60$ – 260 MeV (1992SO02); and polarization observables at $E_n = 0.88$ GeV (1996BB23).

For reaction (e), measurements were reported at thermal neutron energies (1994IT04) and at $E_n < 10$ MeV (1994DR11). For reaction (f), measurements of parity violation with cold polarized neutrons are described in (1990VE16, 1993VE1A, 1996VE02). A discussion of nuclear reaction rates and primordial ${}^6\text{Li}$ is presented in (1997NO04). See also the application-related calculation of (1993FA01).

Theoretical work related to reactions (b), (c), (d), (e), (f) includes: dynamical cluster-model calculation (1991DA08); microscopic calculation in a 3-particle $\alpha + 2\text{N}$ model (1993SH1G); supermultiplet-symmetry-approximation calculation at $E_n = 6.77$ MeV (1993DU09); multiconfiguration RGM calculation (1995FU16); and three-body cluster model calculations of ${}^6\text{Li}(n, p)$ at $E_n = 50$ MeV (1997DA01, 1997ER05).

20. (a) ${}^6\text{Li}(p, p){}^6\text{Li}$	
(b) ${}^6\text{Li}(p, 2p){}^5\text{He}$	$Q_m = -4.497$
(c) ${}^6\text{Li}(p, pd){}^4\text{He}$	$Q_m = -1.4743$
(d) ${}^6\text{Li}(p, p^3\text{H}){}^3\text{He}$	$Q_m = -15.7947$
(e) ${}^6\text{Li}(p, pn){}^5\text{Li}$	$Q_m = -5.39$

Proton angular distributions have been measured for $E_p = 0.5$ to 800 MeV [p_0, p_1, p_2, p_3] [see (1966LA04, 1974AJ01, 1984AJ01)] and at $E_p = 5$ to 17 MeV (1986PF1A; p_0).

Double-differential cross sections for the continuum yield [$E_x = 1.5$ – 3.5 MeV] are reported at $E_p = 65$ MeV (1987TO06). See also (1983GLZZ, 1983PO1B, 1983POZX). More recently differential cross sections and/or polarization observables have been measured at $E_p = 6$ – 10 MeV (1989HA17) [optical model analysis]; $E_p = 1.6$ – 10 MeV (1989HA18) [phase shift analysis]; $E_p = 65, 80$ MeV (1989TO04) [DWIA analysis]; $E_p = 200$ MeV (1990GL04); $E_p = 65$ MeV (1992NA02) [microscopic DWBA analysis]; $E_p = 72$ MeV (1994HE11) [depolarization parameters]; $E_p < 2.2$ MeV (1995SK01) [deduced resonance parameters]; $E_p = 0.88$ GeV (1996BB23) [polarized target]; $E_p = 250$ – 460 keV (1997BR37), $E_p = 280$ MeV (1990MI10) [deduced isospin symmetry test]; $E_p = 14$ MeV [optical model, coupled channels]; $E({}^6\text{Li}) = 62, 72, 75$ MeV/ A , ${}^1\text{H}({}^6\text{Li}, p)$ [neutron halo states] (1996KUZU); $E_p = 1.6$ – 2.4 GeV (1999BB21, 1999DE47). For a summary of the results on excited states see Table 6.12.

Reaction (b) was studied at 70 MeV (1983GO06), at 50 – 100 MeV (1984PA1B, 1985PA1B) and 1 GeV (1985BE30, 1988BE2B, 2000MI17): see ${}^5\text{He}$ and (1984AJ01) for the earlier work. Reaction (c) has been studied at $E_p = 9$ MeV to 1 GeV [see (1974AJ01, 1979AJ01, 1984AJ01)] and at 20 and 42 MeV (1983CA13) [report involvement of ${}^6\text{Li}^*(4.31, 5.65)$], at 70 MeV (1983GO06, 1985PAZL, 1985PA04) and at 119.6 and 200.2 MeV (1984WA09, 1985WA25). In the latter experiments the spectroscopic factors for ${}^6\text{Li}_{g.s.}$ are deduced to be 0.76 [at 119.6 MeV] and 0.84

[at 200.2 MeV] using DWIA and a bound-state Woods-Saxon $2S$ wave function (1984WA09, 1985WA25).

Work on reaction (d) has suggested that the ${}^3\text{He} + t$ parentage of ${}^6\text{Li}$ is comparable with the $\alpha + d$ parentage: see (1984AJ01). See also (1985PAZL). Reaction (e) was studied at $E_p = 70$ MeV (1988PA27). See also ${}^5\text{Li}$, ${}^6\text{Be}$ and (1985BE30, 1993ST06). The (p, 3p) reaction has been studied by (1984NA17). The spectral function for pn pairs in ${}^6\text{Li}$ was obtained in a study of the ${}^6\text{Li}(p, p\alpha)pn$ reaction at $E_p = 200$ MeV (1990WA17). A measurement of tensor analyzing powers in ${}^1\text{H}({}^6\text{Li}, d \text{ or } \alpha \text{ or } t)X$ with 4.5 GeV polarized ${}^6\text{Li}$ deuterons provided information on the ${}^6\text{Li}$ D state (1992PU03). Systematic studies of electron screening effects on low energy reactions including ${}^6\text{Li} + p$ are reported in (1992EN01, 1992EN04, 1995RO37). For antiproton studies see (1987AS06). See also (1984AJ01, 1988AJ01) for the earlier work.

Theoretical work on these reactions reported since the previous review (1988AJ01) is listed in Table 6.13 along with brief descriptions.

21. (a) ${}^6\text{Li}(d, d){}^6\text{Li}$	
(b) ${}^6\text{Li}(d, pn){}^6\text{Li}$	$Q_m = -2.2246$
(c) ${}^6\text{Li}(d, 2d){}^4\text{He}$	$Q_m = -1.4743$
(d) ${}^6\text{Li}(d, \alpha p){}^3\text{H}$	$Q_m = 2.5583$
(e) ${}^6\text{Li}(d, \alpha n){}^3\text{He}$	$Q_m = 1.7946$

Angular distributions of deuterons have been measured at $E_d = 4.5$ to 19.6 MeV [see (1979AJ01)] and at 50 MeV (1988KO1C, 1996RU10). The 0^+ , $T = 1$ state, ${}^6\text{Li}^*(3.56)$ is not appreciably populated. For a summary of the results on excited states see Table 6.12. Gaussian potentials were derived for the description of ${}^6\text{Li} + d$ elastic scattering by (1992DU07).

At $E_d = 21$ MeV reaction (b) shows spectral peaking (characteristic of 1S_0 for the pn system [$T = 1$]) when ${}^6\text{Li}^*(3.56)$ is formed, in contrast with the much broader shape (characteristic of 3S_1) seen when ${}^6\text{Li}^*(0, 2.19)$ are populated. A study of reaction (c) at $E_d = 52$ MeV shows that the α -clustering probability, $N_{\text{eff}} = 0.12_{-0.06}^{+0.12}$ if a Hankel function is used. The α -particle and the deuteron clusters in ${}^6\text{Li}$ have essentially a relative orbital momentum of $l = 0$. The D-state probability of the ground state of ${}^6\text{Li}$ is $\approx 5\%$ of the S-state. Quasi-free scattering is an important process even for $E_d = 6$ to 11 MeV. Interference effects are evident in reaction (c) proceeding through ${}^6\text{Li}^*(2.19, 4.31)$: this is due to the experiment being unable to determine whether the detected particle was emitted first or second in the sequential decay. Reactions (c) and (d) studied at $E_d = 7.5$ to 10.5 MeV indicate that the three-body breakup of ${}^6\text{Li}$ at these low energies is dominated by sequential decay processes (1979AJ01, 1990YA11). Differential cross sections for cluster pickup by 20 MeV/A deuterons on ${}^6\text{Li}$ were measured by (1995MA57).

Calculation of Maxwellian rate parameters for reaction (d) and (e) are described in (2000VO08). See also ${}^8\text{Be}$ and references cited in (1988AJ01).

22. ${}^6\text{Li}(t, t){}^6\text{Li}$

Table 6.12: Parameters of levels of ${}^6\text{Li}$ ^a

E_x (MeV \pm keV)	Γ_{cm} (keV)	Reactions
2.185 \pm 3	20.0 \pm 2.8	${}^4\text{He}(d, d){}^4\text{He}$
2.187 \pm 3		${}^4\text{He}(d, d){}^4\text{He}$
2.188 \pm 6	24 \pm 2 ^b	${}^6\text{Li}(p, p')$, (d, d') , ${}^7\text{Li}(d, t){}^6\text{Li}$
2.203 \pm 6		${}^9\text{Be}(p, \alpha){}^6\text{Li}$
2.186 \pm 2	24 \pm 2	“best” value
3.56288 \pm 0.10 ^c	$(8.2 \pm 0.2) \times 10^{-3}$ ^c	${}^6\text{Li}(\gamma, \gamma){}^6\text{Li}$
4.36 \pm 40	1320 \pm 40	${}^4\text{He}(d, d){}^4\text{He}$
4.27 \pm 40		${}^6\text{Li}(e, e'){}^6\text{Li}$
	1044 \pm 58 ^d	${}^6\text{Li}(e, e'){}^6\text{Li}$
4.40 \pm 120	1490 \pm 150	${}^6\text{Li}(p, p'){}^6\text{Li}$
4.32 \pm 40	1820 \pm 110	${}^6\text{Li}(d, d'){}^6\text{Li}$
4.3 \pm 100	600 \pm 100	${}^7\text{Li}({}^3\text{He}, \alpha){}^6\text{Li}$
4.3 \pm 200	1600 \pm 300	${}^7\text{Li}({}^3\text{He}, \alpha d){}^4\text{He}$
4.3	1600 \pm 120 ^e	${}^7\text{Li}({}^3\text{He}, \alpha d){}^4\text{He}$
4.30 \pm 10	850 \pm 50, 480 \pm 80	${}^9\text{Be}(p, \alpha){}^6\text{Li}$
4.312 \pm 22	1300 \pm 100 ^f	“best” value
5.379 \pm 17 ^g	540 \pm 20 ^g	${}^6\text{Li}(e, e'){}^6\text{Li}$
	546 \pm 36 ^d	${}^6\text{Li}(e, e'){}^6\text{Li}$
5.33 \pm 80	560^{+340}_{-100}	${}^6\text{Li}(p, p'){}^6\text{Li}$
5.34 \pm 20	560 \pm 40 ^b	${}^7\text{Li}({}^3\text{He}, \alpha){}^6\text{Li}$
5.325 \pm 5	270 \pm 12	${}^9\text{Be}(p, \alpha){}^6\text{Li}$
5.366 \pm 15	541 \pm 20 ^h	“best” value
5.65 \pm 50 ⁱ	1900 \pm 100	${}^4\text{He}(d, d){}^4\text{He}$
5.7	1000^{+600}_{-400} ^j	${}^6\text{Li}(p, p'){}^6\text{Li}$
5.65 \pm 200	1650 \pm 300	${}^7\text{Li}({}^3\text{He}, \alpha d){}^4\text{He}$
5.65 \pm 40	900 \pm 60, 1260 \pm 120	${}^9\text{Be}(p, \alpha){}^6\text{Li}$
5.65 \pm 50	1500 \pm 200	“best” value

- ^a For references and other values see Tables 6.5 in (1979AJ01, 1984AJ01, 1988AJ01).
^b See (1988AJ01).
^c (1981RO02).
^d (1979BE38).
^e Average of measurements for $E(^3\text{He}) = 4, 5, 6$ MeV (1995AR14).
^f Weighted average of “best” values from (1988AJ01) and values of 1320 ± 40 keV (Table 6.7), 1044 ± 58 keV (1979BE38), and 1600 ± 120 keV from (1995AR14).
^g See Table 6.4 in (1979AJ01).
^h Weighted average of “best” values from (1988AJ01) and 546 ± 36 keV from (1979BE38).
ⁱ See Table 6.3 in (1979AJ01).
^j See references (c) and (d) in Table 6.5 in (1979AJ01).

At $E_t = 17$ MeV angular distributions have been measured for the tritons to $^6\text{Li}^*(0, 3.56)$: see (1979AJ01).

23. (a) $^6\text{Li}(^3\text{He}, ^3\text{He})^6\text{Li}$
 (b) $^6\text{Li}(^3\text{He}, p\alpha)^4\text{He} \quad Q_m = 16.878$

Angular distributions have been measured at $E(^3\text{He}) = 8$ to 217 MeV [see (1979AJ01, 1984AJ01)] and at 34, 50, 60 and 72 MeV (1986BR31; elastic).

More recently, differential cross sections were measured for elastic scattering at $E(^3\text{He}) = 93$ MeV (1994DO32), and at $E(^3\text{He}) = 60$ MeV (1995MA57), and for inelastic scattering to $^6\text{Li}^*(E_x = 2.185$ MeV, $J^\pi = 3^+$) at $E(^3\text{He}) = 50, 60, 72$ MeV (1995BU20). A microscopic-potential analysis of data at $E(^3\text{He}) = 34, 50, 60, 72$ MeV is described in (1993SI06). Differential cross section and energy spectra were compiled and analyzed by (1995MI16). For reaction (b), cross sections have been measured at $E(^3\text{He}) = 11, 13, 14$ MeV (1989ARZR, 1989AR08); $E(^3\text{He}) = 2.5$ MeV (1989AR20); $E(^3\text{He}) = 1.6$ MeV (1991AR25); $E(^3\text{He}) = 1.6$ –9 MeV (1992AR20); $E(^3\text{He}) = 8$ –14 MeV (1995KO51); $E(^3\text{He}) = 2.0, 22$ MeV (1992DA1K); $E(^3\text{He}) = 7, 9$ MeV (1993AR12). A calculation of near-threshold two-fragment resonance amplitudes and widths for this reaction at $E(^3\text{He}) = 8$ –14 MeV was reported in (1995KO51). See also ^5Li (1984AR17, 1987ZA07) and see ^9B in (1988AJ01).

24. (a) $^6\text{Li}(\alpha, \alpha)^6\text{Li}$
 (b) $^6\text{Li}(\alpha, 2\alpha)^2\text{H} \quad Q_m = -1.4743$

Angular distributions (reaction (a)) have been measured at $E_\alpha = 1.39$ to 166 MeV [see (1974AJ01, 1979AJ01, 1984AJ01)] and at $E_\alpha = 36.6$ and 50.5 MeV (1986BR31). See also (1986ROZK, 1987BU27). See also ^{10}B in (1988AJ01).

More recent measurements at $E_\alpha = 50.5$ MeV of elastic and inelastic ${}^6\text{Li}^*(E_x = 2.185 \text{ MeV}, J^\pi = 3^+)$ were reported by (1994BUZY, 1996BU06). Tensor polarization for inelastic scattering to ${}^6\text{Li}^*(2.185, 3^+)$ has been measured at $E_\alpha = 80$ MeV (1992KO19, 1993KO33). Angular distributions for (α, α') in the continuum region were studied at $E_\alpha = 50$ MeV (1992SA01) and at $E_\alpha = 40$ MeV (1994SA32), at $E_\alpha = 10$ MeV/A (1996SI13) and at $E_\alpha = 119$ MeV (1993OK1A). Cross sections and analyzing powers for elastic scattering of polarized ${}^6\text{Li}$ by ${}^4\text{He}$ are reported for $E({}^6\text{Li}) = 50$ MeV (1995KE10) and $E_{\text{cm}} = 11.1$ MeV (1996GR08).

Studies of continuum coupling effects in inelastic scattering are described in (1995KA1Y, 1995KA43, 1997RU06, 2000RU03). Folding-model potential analyses of elastic scattering are reported in (1993SI09, 1995SA12). Multiconfiguration resonating group methods applied to the ${}^6\text{Li} + \alpha$ system are discussed in (1994FU17, 1995FU11). Other recent theoretical studies include: a potential model description (1999MA02); analysis of density distribution influence (1998GO1J); a phase-shift-analysis determination of the asymptotic D - to S -state ratio (1999GE02); a calculation for $E_\alpha = 16.3$ and 48 MeV with a modified Volkov-potential (2000KO52); and a calculation of the nuclear potential and polarization tensor for $E_\alpha = 27.2$ MeV (2000KO67). See also (1988KO32, 1989LE07, 1999OG09).

Reaction (b) has been studied at $E_\alpha = 6.6$ to 700 MeV: see (1974AJ01, 1979AJ01, 1984AJ01). At the latter energy and using a width parameter of 60.6 MeV/ c the effective number of $\alpha + d$ clusters for ${}^6\text{Li}_{\text{g.s.}}$, $n_{\text{eff}} = 0.98 \pm 0.05$. The results are very model dependent: see (1984AJ01). At $E_\alpha = 27.2$ MeV ${}^6\text{Li}^*(2.19)$ is very strongly populated (1985KO29). See also references cited in (1988AJ01).

In more recent work, two dimensional coincidence spectra of charged particles were measured at $E_\alpha \approx 100$ MeV (1992GA18). Quasi-free scattering processes were studied at $E_\alpha = 77$ – 119 MeV (1992OK01), $E_\alpha = 118$ MeV (1993OK1B), and $E_\alpha = 118.4$ MeV (1997OK01). The four-body ${}^6\text{Li}(\alpha, 2\alpha)\text{pn}$ breakup reaction was measured at $E_\alpha = 77$ – 119 MeV (1992WA18, breakup cross sections); $E_\alpha = 118$ MeV (1988WA29, 1989WA26; spectral functions of pn pair).

25. (a) ${}^6\text{Li}({}^6\text{Li}, {}^6\text{Li}){}^6\text{Li}$

(b) ${}^6\text{Li}({}^6\text{Li}, 2d){}^4\text{He}{}^4\text{He}$ $Q_m = -2.9487$

(c) ${}^6\text{Li}({}^6\text{Li}, \alpha){}^4\text{He}{}^4\text{He}$ $Q_m = 20.8979$

Angular distributions of ${}^6\text{Li}$ ions have been studied for $E({}^6\text{Li}) = 3.2$ to 36 MeV [see (1974AJ01, 1979AJ01, 1984AJ01)] and at $E({}^6\text{Li}) = 2.0$ to 5.5 MeV (1983NO08) and 156 MeV (1985SA36; ${}^6\text{Li}^*(0, 2.19)$), (1985MI05; elastic; ${}^6\text{Li}^*(2.19, 3.56)$ are also populated), (1987EY01; several states in ${}^{12}\text{C}$). Reaction (b) has been studied for $E({}^6\text{Li}) = 36$ to 47 MeV: enhancements in yield, due to double spectator poles, have been observed in d - d and α - α but not in α - d double coincidence spectra. The widths of the peaks are smaller than those predicted from the momentum distribution of $\alpha + d$ clusters in ${}^6\text{Li}$. ${}^6\text{Li}^*(2.19)$ was also populated. See references in (1984AJ01). Other work on reaction (b) is reported by (1984LA19: 2.4 and 4.2 MeV) and by (1985NO1A).

For reaction (c), the energy dependence of quasi-free effects were investigated in the range $E({}^6\text{Li}) = 2.4$ – 6.7 MeV (1987LA25, 1988LA11). An analysis (1996CH1C) used quasi-free data

Table 6.13: ${}^6\text{Li}(p, p){}^6\text{Li}$ – Theoretical work

Reference	Description
1988HA25	${}^6\text{Li}$ proton and neutron transition densities from elastic scattering
1990ZH1R	Quasi resonating group method analysis of ${}^6\text{Li}(p, p){}^6\text{Li}$
1992GA27	Folding-model study of elastic scattering in halo nuclei
1993DU09	Potential description of $N + {}^6\text{Li}$ elastic scattering
1993KO44	Description of ${}^6\text{Li}(p, p){}^6\text{Li}$ with microscopic effective interaction
1993PE13	Folding model description of ${}^6\text{Li}(p, p){}^6\text{Li}$ at 25–50 MeV
1993SA10	DWBA analysis of ${}^6\text{Li}(p, p){}^6\text{Li}$ near the α -d breakup threshold
1994ZH28	Elastic and inelastic proton scattering on ${}^6\text{Li}$ nucleus at intermediate energies
1994ZH34	Glauber-Sitenko diffraction theory calculation of ${}^6\text{Li}(p, p){}^6\text{Li}$
1995GA24	Analysis of properties of exotic nuclei in elastic scattering
1995KA03	Folding-model analysis of ${}^6\text{Li}(p, p'){}^6\text{Li}$ at $E_p = 10$ –136 MeV
1995KA07	Continuum-continuum coupling in ${}^6\text{Li}(p, p'){}^6\text{Li}$ at $E_p = 65$ MeV
1995KA43	Folding-model analysis of ${}^6\text{Li}(p, p'){}^6\text{Li}$ at $E_p = 10$ –136 MeV
1997DO01	Fully microscopic model analyses of ${}^6\text{Li}(p, p'){}^6\text{Li}$ at $E_p = 200$ MeV
1997KA24	Shell model structures of ${}^6\text{Li}$ states excited in ${}^6\text{Li}(p, p'){}^6\text{Li}$
1998DO16	Microscopic analysis of ${}^6\text{Li}(p, p)$ at $E_p = 65$ MeV
1998FUZP	Microscopic optical model calculation for $E_p = 60$ –70 MeV
2000TI02	Finite-range coupled channels calculation for ${}^6\text{He} + p$ rxn
2000DE61	Microscopic model analysis of ${}^6\text{Li}(p, p){}^6\text{Li}$ for $E_p = 25, 30, 40$ MeV
2000LA40	Resonance optical model analysis for ${}^6\text{Li}(p, p){}^6\text{Li}$ for $E_p = 1$ –10 MeV
2000ZH40	Glauber-Sitenko diffraction theory calculation for $E_p = 0.16$ –1.04 GeV
2001AR05	Microscopic multicluster calculation for ${}^6\text{He} + p$ at $E_{\text{cm}} = 0$ –5 MeV

from reaction (c) to extract the ${}^6\text{Li}(d, \alpha){}^4\text{He}$ excitation function at astrophysical energies. See also ${}^{12}\text{C}$ in (1985AJ01) and references cited in (1988AJ01).

More recently, elastic scattering angular distributions were measured for $E({}^6\text{Li}) = 5$ –40 MeV (1997PO03; optical model analysis). Eikonal-approximation calculations of differential cross sections and phase shifts for $E({}^6\text{Li}) = 156$ MeV were reported in (1992EL1A).

26. ${}^6\text{Li}({}^7\text{Li}, {}^7\text{Li}){}^6\text{Li}$

Angular distributions have been measured at $E({}^7\text{Li}) = 78$ MeV to ${}^6\text{Li}^*(0, 2.19)$ (1986GLZU), and at $E({}^7\text{Li}) = 9$ –40 MeV (1998PO03).

27. ${}^6\text{Li}({}^9\text{Be}, {}^9\text{Be}){}^6\text{Li}$

The elastic scattering has been studied in inverse kinematics at $E(^6\text{Li}) = 4.0, 6.0$ and 24 MeV [see (1979AJ01)], at 32 MeV (1985CO09) and at 50 MeV (1988TRZY; also inelastic). Recently angular distributions for elastic and inelastic scattering to $^6\text{Li}^*(2.186, 3^+)$ were measured (1995MU01) at $E_{\text{cm}} = 7, 10, 12$ MeV. Excitation functions for $E_{\text{cm}} \approx 4\text{--}12$ were also reported. See also ^9Be in (1988AJ01). For the interaction cross section at $E(^6\text{Li}) = 790$ MeV/ A see (1985TA18).

28. $^6\text{Li}(^{10}\text{B}, ^{10}\text{B})^6\text{Li}$

The elastic scattering has been studied at $E(^6\text{Li}) = 5.8$ and 30 MeV: see (1979AJ01).

29. (a) $^6\text{Li}(^{12}\text{C}, ^{12}\text{C})^6\text{Li}$

(b) $^6\text{Li}(^{13}\text{C}, ^{13}\text{C})^6\text{Li}$

(c) $^6\text{Li}(^{14}\text{C}, ^{14}\text{C})^6\text{Li}$

The elastic and inelastic scattering (reaction (a)) has been studied at $E(^6\text{Li}) = 4.5$ to 156 MeV [see (1984AJ01)] and at $E(^6\text{Li}) = 19.2$ MeV (1983RU09), 36 and 45 MeV [and $E(^{12}\text{C}) = 72$ and 90 MeV] (1984VI02, 1985VI03; also to $^6\text{Li}^*(2.19, 4.31)$ and to various states of ^{12}C), at $E(^{12}\text{C}) = 58.4$ MeV (1987PA12), 90 MeV (1987DE02; also to various states of ^{12}C), 123.5 and 168.6 MeV (1988KA09; and to various states of ^{12}C), 150 MeV (1987TA21, 1988TA08), 156 MeV (1987EY01; and to various states in ^{12}C) and at 210 MeV (1988NA02). See also (1986SHZP, 1987PA12). More recently, measurements of cross sections and/or analyzing power observables have been reported at $E(^6\text{Li}) = 93$ MeV (1989DE34); at $E_{\text{cm}} = 13.3$ MeV ((1989HN1A, 1995CA26) and to $^6\text{Li}^*(3^+, 2.186)$ and $^{12}\text{C}^*(2^+, 4.44)$); at $E(^6\text{Li}) = 210$ MeV (1989NA11, to $^{12}\text{C}^*(2^+, 4.44)$); at $E(^6\text{Li}) = 30$ MeV (1989VA04, to $^{12}\text{C}^*(2^+, 4.44)$); at 50 MeV (1990TR02, to $^{12}\text{C}^*(2^+, 4.44; 0^+, 7.65; 3^-, 9.64)$); at $E(^6\text{Li}) = 30$ MeV (1994RE01); at $E(^6\text{Li}) = 30, 60$ MeV (1996KE09, to $^{12}\text{C}^*(2^+, 4.44; 0^+, 7.65; 3^-, 9.64)$); at $E_{\text{cm}} = 20$ MeV (1996GA29, to $^6\text{Li}^*(3^+, 2.18)$ and $^{12}\text{C}^*(2^+, 4.44)$); at $E(^6\text{Li}) = 318$ MeV (1993NA01); at $E(^6\text{Li}) = 30$ MeV (1994RE15, to $^{12}\text{C}^*(2^+, 4.44; 3^-, 9.64)$); and at $E(^6\text{Li}) = 50$ MeV (1995KE10). At $E(^6\text{Li}) = 34$ MeV the d- α angular correlations involve $^6\text{Li}^*(0, 2.19)$ (1985CU04). See also (1988SE07), and see ^{12}C in (1985AJ01, 1990AJ01). An experimental study of the $\alpha + d$ breakup in $^6\text{Li} + ^{12}\text{C}$ collision at $E(^6\text{Li}) = 156$ MeV is reported in (1989JE01). For pion production see (1984CH16). For the interaction cross section at $E(^6\text{Li}) = 790$ MeV/ A see (1985TA18). For VAP measurements at $E(^6\text{Li}) = 30$ MeV see (1988VAZY). Fusion cross sections for $E(^6\text{Li}) = 3.11\text{--}12.07$ MeV are reported by (1998MU12).

The elastic scattering (reaction (b)) has been studied for $E(^6\text{Li}) = 5.8$ to 40 MeV: see (1984AJ01). Measurements of differential cross sections for $E_{\text{cm}} = 26$ MeV and observations of a nuclear quasi rainbow were reported by (1994DE43). See also (1987CA30, 1988WO10). The elastic scattering (reaction (c)) has been measured for $E(^6\text{Li}) = 93$ MeV (1987DE02). See also ^{18}F and ^{19}F in (1987AJ02) and references cited in (1988AJ01).

Several theoretical studies relating to ${}^6\text{Li} + {}^{12}\text{C}$ have been reported. The role of the Pauli Principle in heavy ion scattering has been studied (1988GR32). The dispersive contribution to the ${}^6\text{Li} + {}^{12}\text{C}$ real potential was estimated (1990KA14). Elastic cross sections for $E({}^6\text{Li}) = 30$ MeV were analyzed (1990SA05). A semimicroscopic analysis of inelastic scattering at $E({}^6\text{Li}) = 156$ MeV is described in (1992GA17). Folding model analysis of ${}^6\text{Li} + {}^{12}\text{C}$ scattering is discussed in (1994NA03, 1994SA10, 1995KH03). Differential cross sections were analyzed with an S -matrix approach by (1998PI02).

Other theoretical descriptions of ${}^6\text{Li} + {}^{12}\text{C}$ scattering are discussed in (1994SA33; strong absorption model), (1995IS1F; multiple diffraction interaction), and (1996CA01; microscopic description).

30. ${}^6\text{Li}({}^{16}\text{O}, {}^{16}\text{O}){}^6\text{Li}$

Elastic angular distributions have been reported at $E({}^6\text{Li}) = 4.5$ to 50.6 MeV [see (1984AJ01)], at $E({}^6\text{Li}) = 35.3$ and $E({}^{16}\text{O}) = 94.2$ MeV (1984VI02) and at 50 MeV (1988TRZY; also inelastic). At $E({}^6\text{Li}) = 25.7$ and $E({}^{16}\text{O}) = 68.6$ MeV (1984VI01, 1985VI03) report some $\sigma(\theta)$ to ${}^6\text{Li}^*(2.19)$ [and to ${}^{16}\text{O}^*(6.13)$]. See also (1987PA12). See (1985VI03, 1986SC28) for studies of the breakup. Polarization observables have been measured at $E({}^6\text{Li}) = 25.7$ MeV, and also using ${}^{16}\text{O}$ ions (1987VAZY, 1989VA04). Measurements of $E({}^6\text{Li}) = 50$ MeV for elastic scattering and inelastic scattering to ${}^{16}\text{O}^*(2^+, 6.05; 3^-, 6.13; 2^+, 6.92; 1^-, 7.12)$ were reported (1990TR02). For fusion cross sections see (1986MA19). See also ${}^{16}\text{O}$ in (1986AJ04), (1986MO1E, 1987PA12) and references cited in (1988AJ01). Theoretical work on this scattering reaction includes: $E({}^6\text{Li}) = 29.8$ MeV, optical model description (1990SA05); $E({}^6\text{Li}) = 29.8$ – 30.6 MeV, Pauli Principle rule (1988GR32); $E({}^6\text{Li}) = 30.6$, optical model analysis (1990SA05); projectile effects (1991BO48); $E({}^6\text{Li}) = 154$ MeV, 3-body cluster model (1991HI07); $E({}^6\text{Li}) = 22.8$ MeV, nonresonant breakup states (1991HI11); and $E({}^6\text{Li}) = 30$ MeV, double-folding model, role of Pauli Principle (1991SA26).

31. (a) ${}^6\text{Li}({}^{24}\text{Mg}, {}^{24}\text{Mg}){}^6\text{Li}$
 (b) ${}^6\text{Li}({}^{25}\text{Mg}, {}^{25}\text{Mg}){}^6\text{Li}$
 (c) ${}^6\text{Li}({}^{26}\text{Mg}, {}^{26}\text{Mg}){}^6\text{Li}$
 (d) ${}^6\text{Li}({}^{27}\text{Al}, {}^{27}\text{Al}){}^6\text{Li}$

Elastic scattering for reaction (a) was studied at $E({}^6\text{Li}) = 156$ MeV (1995DE53). Reaction (c) has been studied at $E({}^6\text{Li}) = 88$ MeV and 36 MeV (1984AJ01) and at 44 MeV (1989RU05; polarization observables), and $E({}^6\text{Li}) = 60$ MeV (1994WA20; polarization observables). Reaction (d) was studied at $E({}^6\text{Li}) = 156$ MeV by (1987NI04; particles and gammas from inelastic scattering). See also the measurements at $E({}^6\text{Li}) = 790$ MeV/ A (1985TA18).

Theoretical studies for these reactions include: analyzed non-Rutherford cross sections (1991BO48); effects of nonresonant breakup states (1991HI11); strong absorption model analysis (1994SA33); cluster folding interaction (1991HI07); coupled channels study (1992HI02); and cluster-folding analysis (1994RU11).

32. (a) ${}^6\text{Li}({}^{28}\text{Si}, {}^{28}\text{Si}){}^6\text{Li}$
 (b) ${}^6\text{Li}({}^{30}\text{Si}, {}^{30}\text{Si}){}^6\text{Li}$

The elastic scattering has been studied at $E({}^6\text{Li}) = 13$ to 154 MeV [see (1984AJ01)], at 27 and 34 MeV (1983VI03) and at 210 MeV (1988NAZX). For a study of the decay see (1987NI04). See also references cited in (1988AJ01).

More recent measurements have been reported at $E({}^6\text{Li}) = 210$ MeV (inelastic $\sigma(\theta)$ to ${}^{28}\text{Si}^*$ (first 2^+ state) (1989NA11); elastic $\sigma(\theta)$, optical parameters (1989NA02); and $E({}^6\text{Li}) = 318$ MeV ($\sigma(\theta)$, folding model potentials (1990NAZZ, 1993NA01)). Related analyses and other theoretical studies include: Pauli Principle role (1988GR32, 1991SA26); scattering matrix approach (1990KU23); deduced model parameters (1990SA05); non-Rutherford cross section thresholds (1991BO48); cluster-folding interactions (1991HI07); energy dependence, dispersion relation (1991TI04); strong absorption model (1994SA33); $E({}^6\text{Li}) = 210, 318$ MeV, energy approximation (1995EM03); microscopic description (1996CA01); microscopic potentials, density matrix formalism (1996KN02); $E({}^6\text{Li}) = 35, 53$ MeV/A, breakup effect (1997SA57); and $E({}^6\text{Li}) = 210, 315$ MeV, S -matrix approach (1998PI02).

For reaction (b) see (1987AR13).

33. (a) ${}^6\text{Li}({}^{39}\text{K}, {}^{39}\text{K}){}^6\text{Li}$
 (b) ${}^6\text{Li}({}^{40}\text{Ca}, {}^{40}\text{Ca}){}^6\text{Li}$
 (c) ${}^6\text{Li}({}^{44}\text{Ca}, {}^{44}\text{Ca}){}^6\text{Li}$
 (d) ${}^6\text{Li}({}^{48}\text{Ca}, {}^{48}\text{Ca}){}^6\text{Li}$

Elastic scattering has been studied for $E({}^6\text{Li}) = 26$ to 99 MeV: see (1984AJ01, 1988AJ01), and at $E({}^6\text{Li}) = 34$ MeV (reaction (b)) by (1987VA31) and at 210 MeV (1988NAZX, 1989NA02; reaction (b)). ${}^6\text{Li}^*(2.19)$ has been studied at $E({}^{40}\text{Ca}) = 227$ MeV (1987VA31). Reaction (d) was studied at $E({}^6\text{Li}) = 150$ MeV (1990KAZH). For fusion measurements (reaction (b)) see (1984BR04). For breakup measurements (reaction (b)) see (1984GR20, 1990YA09, 1992YAZW, 1993GU10, 1995AR15, 1996YA01).

For theoretical studies related to these reactions see: energy and target dependence of projectile breakup (1987SA21); sequential breakup cross sections (1987VA31); role of Pauli Principle (1988GR32); exchange effects (1988KH08, 1990DA23); imaginary part of channel-coupling potentials (1990TA11); $E({}^6\text{Li}) = 30$ MeV, deduced optical model parameters (1990SA05); cluster folding interactions (1991HI07); strong absorption model (1994SA33); S -matrix approach

(1995BE60, 1998PI02); and microscopic potentials (1996KN02). For earlier work see references cited in (1988AJ01).

$$34. \text{ (a) } {}^7\text{Li}(\gamma, n){}^6\text{Li} \quad Q_m = -7.249$$

$$\text{ (b) } {}^7\text{Li}(\gamma, p\pi^-){}^6\text{Li} \quad Q_m = -146.038$$

Transitions to ${}^6\text{Li}^*(0, 2.19, 3.56)$ have been observed in reaction (a): see (1979AJ01, 1984AJ01). Differential cross sections are reported for $E_{\text{brem}} = 60$ to 120 MeV for the $n_0 + n_2$ groups (1985SE17). Bremsstrahlung yield for (γ, n_0) was measured for $E_\gamma = 7-9$ MeV (1989KA30). Reaction (b) at 0.9 GeV involves ${}^6\text{Li}^*(2.19)$ (1985RE1A). See also the measurements of $E_\gamma = 350$ MeV reported by (1991GA26), and see ${}^7\text{Li}$, (1985ST1A, 1986BA2G, 1986GO1M).

An analysis of ${}^7\text{Li}(\gamma, n)$ data in the giant resonance energy region is described in (1987VA05). Cluster effects were explored in (1992VA12). Calculation with a potential two cluster model are reported in (1997DU02).

$$35. {}^7\text{Li}(\pi^-, \pi^-p){}^6\text{He} \quad Q_m = -9.9754$$

Quasielastic pion-proton backward scattering was measured at $E_\pi = 0.7, 0.9, 1.25$ GeV (2000AB25). Fermi momentum distributions for ${}^6\text{Li}$ were deduced.

$$36. {}^7\text{Li}(\pi^+, p){}^6\text{Li} \quad Q_m = 133.1026$$

Differential cross sections have been measured at $E_{\pi^+} = 75$ and 175 MeV for the transitions to ${}^6\text{Li}^*(0, 2.19)$: see (1984AJ01). Proton spectra measured at momentum exchange 660 MeV/c (1989LIZO) provided evidence for an η -meson nuclear bound state.

$$37. \text{ (a) } {}^7\text{Li}(p, d){}^6\text{Li} \quad Q_m = -5.0254$$

$$\text{ (b) } {}^7\text{Li}(p, pn){}^6\text{Li} \quad Q_m = -7.2499$$

Angular distributions of deuterons (reaction (a)) have been studied for $E_p = 167$ to 800 MeV [see (1979AJ01, 1984AJ01)] and at 18.6 MeV (1986GO23, 1987GO27; d_0, d_1, d_2 ; see for spectroscopic factors), 200 and 400 MeV (1985KR13; $d_0, d_1; d_2$ is weakly populated at 200 MeV) and at 800 MeV (1984SM04; d_0, d_1). The ratio of the intensities of the groups to ${}^6\text{Li}^*(2.19)$ and ${}^6\text{Li}_{\text{g.s.}}$ increases with energy. It is suggested that this can be understood in terms of a small admixture of 1f orbital in these states (1985KR13). A DWBA analysis of $E_p = 185$ MeV data leads to $C^2S = 0.87, 0.67, 0.24, (0.05), 0.14$, respectively for ${}^6\text{Li}^*(0, 2.19, 3.56, 4.31, 5.37)$. No

other states were seen below $E_x \approx 20$ MeV: see (1979AJ01). The tensor analyzing power T_{20} was measured for the $^1\text{H}(^7\text{Li}, \text{d})^6\text{Li}$ reaction at $E(^7\text{Li}) = 70$ MeV to $^6\text{Li}^*(0, 2.186)$ (1991DA07). Data at $E_p = 33.6$ MeV were analyzed by (1991AB04) in a test for Cohen-Kurath wave functions. See also the analysis of data at $E_p = 698$ MeV by (1993AL05; η production). In reaction (b) at $E_p = 1$ GeV the separation energy between ≈ 6.5 MeV broad $1p_{3/2}$ and $1s_{1/2}$ groups is reported to be 18.0 ± 0.8 MeV (1985BE30, 1985DO16). See also (1983LY04, 1988BE11, 1988GUZW). Differential cross sections were measured at $E_p = 70$ MeV (1988PA26) and at $E_p = 2.7\text{--}3.8$ MeV (1988BO37; application). See also the measurements for nuclear microprobe utilization (1995RI14).

38. $^7\text{Li}(\text{d}, \text{t})^6\text{Li}$ $Q_m = -0.9927$

A study at $E_d = 23.6$ MeV of the relative cross sections of the analog reactions $^7\text{Li}(\text{d}, \text{t})^6\text{Li}$ (to the first two $T = 1$ states at 3.56 and 5.37 MeV) and $^7\text{Li}(\text{d}, ^3\text{He})^6\text{He}$ (to the ground and 1.80 MeV excited states) shows that $^6\text{Li}^*(3.56, 5.37)$ have high isospin purity ($\alpha^2 < 0.008$): this is explained in terms of antisymmetrization effects which prevent mixing with nearby $T = 0$ states: see (1979AJ01). (1987BO39) [$E_d = 30.7$ MeV] deduce that the branching ratio of $^6\text{Li}^*(4.31)$ [2^+] into a dinucleon [$T = 1, S = 0$] is $(85 \pm 10)\%$: see also reactions 21 in ^6He and 4 in ^6Be . See also (1987GUZZ; $E_d = 18$ MeV; angular distributions to $^6\text{Li}^*(0, 2.19, 3.56)$) and (1984BL21, 1986AV01, 1988GUZW). See also the analysis method discussed in (1995GU22; DWBA and dispersive theory).

39. (a) $^7\text{Li}(^3\text{He}, \alpha)^6\text{Li}$ $Q_m = 13.3277$
 (b) $^7\text{Li}(^3\text{He}, \text{d}\alpha)^4\text{He}$ $Q_m = 11.8534$

Angular distributions have been reported at $E(^3\text{He}) = 5.1$ to 33.3 MeV [see (1974AJ01, 1984AJ01): the lower energy work has not been published] and more recently at $E(^3\text{He}) = 60$ MeV (1994BUZX). Excited states observed in this reaction are displayed in Table 6.12. See also (1968CO07) which reported observation of ^6Li states at $0.0, 2.17 \pm 0.02, 3.55 \pm 0.02$ and 5.34 ± 0.02 MeV. (1986AN04) have analyzed unpublished data which suggest the involvement of several broad highly excited states of ^6Li . See also (1987AL23).

Several attempts have been made to observe the isospin-forbidden decay of $^6\text{Li}^*(5.37)$ [$2^+; 1$] via $^7\text{Li}(^3\text{He}, \alpha)^6\text{Li}^* \rightarrow \text{d} + \alpha$: the branching is $< 1\%$. $\Gamma_p/\Gamma = 0.35 \pm 0.10$ and $\Gamma_{p+n}/\Gamma = 0.65 \pm 0.10$ for $^6\text{Li}^*(5.37)$: see (1979AJ01). $^4\text{He} + \text{d}$ spectra suggest the excitation of $^6\text{Li}^*(4.3)$ [$E_x = 4.3 \pm 0.2$ MeV, $\Gamma = 1.6 \pm 0.3$ MeV] and $^6\text{Li}^*(5.7)$ [$E_x = 5.65 \pm 0.2$ MeV, $\Gamma = 1.65 \pm 0.3$ MeV]: see (1984AJ01). See also (1985DA29, 1988BO1Y). A more recent measurement at $E(^3\text{He}) = 4, 5, 6$ MeV (1995AR14) gave values for the width of $^6\text{Li}^*(4.31)$ in agreement with the adopted value $\Gamma = 1700 \pm 200$ keV and found no dependence on incident energy. Measurements of $\text{d}-\alpha$ coincidence spectra at $E(^3\text{He}) = 11.5$ MeV (1988AR20) and 5.0 MeV (1991AR19) gave spectroscopic

parameters for ${}^6\text{Li}^*(5.65)$ in agreement with adopted values (1988AJ01). At $E({}^3\text{He}) = 120$ MeV the missing mass spectra for (${}^3\text{He}$, 2d) and (${}^3\text{He}$, pt) reflect the population of ${}^6\text{Li}^*(0, 2.19)$ and suggest broad structures at $E_x = 28.5$ and 32.9 MeV (1985FR01). See also ${}^{10}\text{B}$ in (1988AJ01) and (1983KU17, 1988BO1J).

$$40. \text{ (a) } {}^7\text{Li}({}^6\text{Li}, {}^7\text{Li}){}^6\text{Li} \\ \text{ (b) } {}^7\text{Li}({}^7\text{Li}, {}^8\text{Li}){}^6\text{Li} \quad Q_m = -5.2171$$

At $E({}^6\text{Li}) = 93$ MeV a broad group ($\Gamma \approx 11$ MeV) centered at $E_x = 20$ MeV is reported in addition to other peaks at $E_x = 17.1 \pm 0.3$, 18.9 ± 0.3 and 21.2 ± 0.3 MeV (1987GLZW). See (1984KO25) for reaction (b).

$$41. {}^9\text{Be}(\gamma, t){}^6\text{Li} \quad Q_m = -17.6885$$

Cross section measurements were made with virtual photons using electrons at 21.0–39.0 MeV (1999SH05). A compilation and evaluation of cross section data for $E_\gamma < 30$ MeV has been done by (1999ZHZN).

$$42. \text{ (a) } {}^9\text{Be}(\text{p}, \alpha){}^6\text{Li} \quad Q_m = 2.1254 \\ \text{ (b) } {}^9\text{Be}(\text{p}, 2\alpha){}^2\text{H} \quad Q_m = 0.6510 \\ \text{ (c) } {}^9\text{Be}(\text{p}, \text{pt}){}^6\text{Li} \quad Q_m = -17.6885$$

Angular distributions of α -particles (reaction (a)) have been measured at $E_p = 0.11$ to 45 MeV. [see (1974AJ01, 1979AJ01)] and at $E_p = 22.5$, 31 and 41 MeV (1986HA27; $\alpha_0, \alpha_1, \alpha_2$; see for spectroscopic factors). See also Table 6.12 and (1984AJ01). Recent measurements of angular distributions and analyzing power at $E_p = 77$ –321 keV are reported by (1998BR10). Measurements at $E_x = 1$ GeV are reported in (2000ANZX). Calculations of the cross section and polarization observables for $E_p = 40$ MeV are reported in (2000GA49, 2000GA59). A study of possible reasons for non-observation of certain ${}^6\text{Li}$ excited states in the reaction is discussed in (1999TI07). ${}^6\text{Li}^*(3.56)$ decays by γ -emission consistent with M1; $\Gamma_\alpha/\Gamma < 0.025$ [forbidden by spin and parity conservation]: see (1984AJ01). An analysis of the ${}^9\text{Be}(\text{p}, \alpha)$ cross section at $E_p = 16$ –700 keV is described in (2001BA47). Astrophysical S -factor, analyzing powers and R -matrix parameters were deduced. At $E_p = 9$ MeV the yield of reaction (b) is dominated by FSI through ${}^8\text{Be}^*(0, 2.9)$ and ${}^6\text{Li}^*(2.19)$ with little or no yield from direct three-body decay: see (1979AJ01). More recent measurements of cross sections and/or polarization observables have been reported at $E_p = 50$ MeV (1989GU05), $E_p = 25, 30$ MeV (1992PE12; determined spectroscopic strengths), $E_p = 40$ MeV (1997FA17) [see also (1989FA1B)], $E_p = 2$ –5 MeV (1988ABZW), $E_p = 16$ –390 keV

[deduced $S(E)$] (1997ZA06), $E_p = 77\text{--}321$ keV [deduced stellar reaction rates] (1998BR10), $E_p = 30\text{--}300$ keV (2000ISZZ). See also application-related experiments (1990RE09, 1995RI14). Analyses of data for this reaction have been reported for $E_p = 45\text{--}50$ MeV [DWBA] (1996YA09, 1997YAZV) and $E_p < 2$ MeV [analyzed reaction rates, primordial ${}^6\text{Li}$] (1997NO04). Reactions (b) and (c) at $E_p = 58$ MeV involve ${}^6\text{Li}^*(0, 2.19)$ (1985DE17). See also ${}^{10}\text{B}$ in (1988AJ01) and (1985MAZG, 1986AN26, 1986KA26).

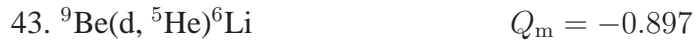

See ${}^5\text{He}$.



Angular distributions of ${}^6\text{He}_{g.s.} + {}^6\text{Li}_{g.s.}$ and ${}^6\text{He}_{g.s.} + {}^6\text{Li}^*(3.56)$ [both ions listed were detected] have been measured at $E_t = 21.5$ and 23.5 MeV. In the latter case the final state is composed of two isobaric analog states: angular distributions are symmetric about 90° cm, within the overall experimental errors. In the reaction leading to the ground states of ${}^6\text{He}$ and ${}^6\text{Li}$ differences from symmetry of as much as 40% are observed at forward angles. Angular distributions involving ${}^6\text{He}_{g.s.} + {}^6\text{Li}^*(2.19)$ and ${}^6\text{Li}_{g.s.} + {}^6\text{He}^*(1.8)$ have also been measured. This reaction appears to proceed predominantly by means of the direct pickup of a triton or ${}^3\text{He}$ from ${}^9\text{Be}$. Differential cross sections are also reported at $E_t = 17$ MeV: see (1984AJ01) for references.



Angular distributions of ${}^6\text{Li}$ ions have been obtained at $E({}^3\text{He}) = 6$ to 10 MeV: see (1974AJ01). A study of the continuum suggests the population of ${}^6\text{Li}$ states at $E_x = 8\text{--}12, \approx 21$ and 21.5 MeV: see (1984AJ01). More recently, measurements at $E({}^3\text{He}) = 60$ MeV of differential cross sections have been reported (1990MA10, 1990MAZG, 1995MA57). Spectroscopic factors were deduced. Angular distributions at $E({}^3\text{He}) = 60$ MeV for transition to the ${}^6\text{Li}$ ground state and to ${}^6\text{Li}^*(3^+, 2.185; 2^+, 5.37; 1^+, 5.65)$ were measured (1996RU13) and analyzed by coupled-channels methods.



Differential cross sections are reported at $E_n = 14.4$ MeV involving ${}^6\text{Li}^*(2.19)$ and ${}^5\text{He}_{g.s.}$ (1984TU02).

47. $^{10}\text{B}(\text{d}, ^6\text{Li})^6\text{Li}$ $Q_m = -2.9861$

Angular distributions involving $^6\text{Li}^*(0, 2.19)$ have been studied at $E_d = 13.6$ MeV (1983DO10) and at 19.5 MeV [see (1974AJ01)]. See also (1984SHZJ).

48. $^{10}\text{B}(^3\text{He}, ^7\text{Be})^6\text{Li}$ $Q_m = -2.8738$

Angular distributions involving $^6\text{Li}^*(0, 2.19)$ have been measured at $E(^3\text{He}) = 30$ MeV: see (1974AJ01).

49. $^{10}\text{B}(\alpha, ^8\text{Be})^6\text{Li}$ $Q_m = -4.5522$

At $E_\alpha = 72.5$ MeV only $^6\text{Li}^*(0, 2.19)$ are observed: the latter is excited much more strongly than is the ground state [S_α for the ground state is 0.4 that for $^6\text{Li}^*(2.19)$]. The angular distributions for both transitions are flat: see (1979AJ01). See also (1984AJ01). A more recent measurement of differential cross sections at $E_\alpha = 27.2$ MeV is reported in (1995FA21). Spectroscopic factors were deduced.

50. $^{11}\text{B}(\text{d}, ^7\text{Li})^6\text{Li}$ $Q_m = -7.1903$

See (1984AJ01).

51. $^{11}\text{B}(^3\text{He}, ^8\text{Be})^6\text{Li}$ $Q_m = 4.5712$

Angular distributions are reported at $E(^3\text{He}) = 71.8$ MeV involving several states in ^8Be (1986JA02, 1986JA14).

52. $^{12}\text{C}(\text{p}, ^7\text{Be})^6\text{Li}$ $Q_m = -22.5668$

Angular distributions involving $^7\text{Be}^*(0, 0.43)$ have been measured at $E_p = 40.3$ MeV (1985DE05). For the earlier work at $E_p = 30.6$ to 56.8 MeV see (1974AJ01, 1979AJ01). See also references cited in (1988AJ01).

53. $^{12}\text{C}(\text{d}, ^8\text{Be})^6\text{Li}$ $Q_{\text{m}} = -5.8922$

Angular distributions involving states in ^8Be have been studied at $E_{\text{d}} = 19.5$ and 51.8 MeV [see (1974AJ01)] and at 50 MeV (1985GO1G, 1989GO07, 1989GO26), 54.2 MeV (1984UM04) and 78 MeV (1986JA14), as well as at $E_{\text{d}} = 18$ and 22 MeV (1987TA07) and 51.7 MeV (1986YA12). See also (1984NE1A, 1987GO1S) and the DWBA calculations at $E_{\text{d}} = 50$ MeV (1988KA46) and $E_{\text{d}} = 15$ MeV (1988RA27).

54. $^{12}\text{C}(^3\text{He}, ^9\text{B})^6\text{Li}$ $Q_{\text{m}} = -11.5708$

Angular distributions have been obtained at $E(^3\text{He}) = 28$ to 40.7 MeV [see (1974AJ01)] and at $E(^3\text{He}) = 33$ MeV (1989SI02), $E(^3\text{He}) = 33.4$ MeV (1986CL1B; also A_{y}), $E(^3\text{He}) = 60$ MeV (1990MAZG, 1993MA48), $E(^3\text{He}) = 30$ – 60 MeV (1995MA57). See also (1989GL1D) and see ^9B in (1988AJ01).

55. (a) $^{12}\text{C}(\alpha, ^{10}\text{B})^6\text{Li}$ $Q_{\text{m}} = -23.7122$
 (b) $^{12}\text{C}(\alpha, \text{d}\alpha)^{10}\text{B}$ $Q_{\text{m}} = -25.1865$

Angular distributions (reaction (a)) at $E_{\alpha} = 42$ MeV involve $^6\text{Li}^*(0, 2.19)$: see (1974AJ01). Differential cross sections were measured at $E_{\alpha} = 90$ MeV and cluster spectroscopic amplitudes were deduced (1991GL03). At $E_{\alpha} = 65$ MeV reaction (b) goes via $^6\text{Li}^*(2.19, 4.31)$: see (1984AJ01). See also ^{10}B in (1988AJ01) and (1987GA20).

56. (a) $^{12}\text{C}(^6\text{Li}, \alpha)^{14}\text{N}$ $Q_{\text{m}} = 8.7980$
 (b) $^{12}\text{C}(^6\text{Li}, \alpha\text{d})^{12}\text{C}$ $Q_{\text{m}} = -1.4743$

An analysis involving excited states of ^6Li and ^{14}N was applied to cross section and analyzing power data at $E(^6\text{Li}) = 33$ MeV by (2000MA43).

Measurements of triple differential cross sections for elastic breakup of 156 MeV ^6Li (reaction (b)) were reported in (1989HE28, 1989HE17, 1989RE1G). A diffraction dissociation model analysis was used. See also reaction 70. Partial cross sections for the $^6\text{Li} + ^{12}\text{C}$ reaction were measured for $E(^6\text{Li}) = 3.11$ – 12.07 MeV by (1998MU12).

57. $^{12}\text{C}(^{10}\text{B}, ^{16}\text{O})^6\text{Li}$ $Q_{\text{m}} = 2.7015$

See ^{16}O in (1986AJ04).

$$58. \ ^{12}\text{C}(^{11}\text{B}, \ ^6\text{Li})^{17}\text{O} \quad Q_{\text{m}} = -4.609$$

Measurements of angular distributions at $E(^{11}\text{B}) = 25, 35, 40$ MeV have been reported by (1996JA12). Transfer mechanisms were studied.

$$59. \ ^{12}\text{C}(^{12}\text{C}, \ ^{12}\text{C})^6\text{Li}^6\text{Li} \quad Q_{\text{m}} = -28.1726$$

The fragmentation of ^{12}C into two ^6Li ions has been observed at $E(^{12}\text{C}) = 2.1$ GeV/A (1986LIZP).

$$60. \ ^{12}\text{C}(^{14}\text{N}, \ ^{20}\text{Ne})^6\text{Li} \quad Q_{\text{m}} = -4.1810$$

Angular distributions of reaction products were measured for $E(^{14}\text{N}) = 50$ MeV, and multi-nucleon transfer mechanisms were studied (1992ARZX). See also the analysis for $E(^{14}\text{N}) = 54$ MeV (1987GO12), and see ^{20}Ne in (1987AJ02, 1998TI06).

$$61. \ ^{13}\text{C}(\text{p}, \ ^8\text{Be})^6\text{Li} \quad Q_{\text{m}} = -8.6140$$

See (1974AJ01).

$$62. \ ^{13}\text{C}(\text{t}, \ ^6\text{Li})^{10}\text{Be} \quad Q_{\text{m}} = -8.6181$$

Measurements of differential cross sections and analyzing powers were reported by (1989SI02). Spectroscopic factors were extracted.

$$63. \ ^{13}\text{C}(^3\text{He}, \ ^6\text{Li})^{10}\text{B} \quad Q_{\text{m}} = -8.0809$$

Differential cross sections at $E(^3\text{He}) = 60$ MeV have been reported (1990MAZG, 1995MA57). Cluster pick-up mechanisms were studied.

64. $^{16}\text{O}(\text{d}, ^{12}\text{C})^6\text{Li}$ $Q_m = -5.6876$

Angular distributions and polarization observables involving ^6Li ions and several ^{12}C states are reported at $E_d = 22$ MeV (1987TA07) and 51.7 MeV (1986YA12) and at $E_d = 54.2$ MeV (1984UM04). See also (1984NE1A), and ^{12}C in (1990AJ01) for polarization studies.

65. $^{16}\text{O}(^3\text{He}, ^6\text{Li})^{13}\text{N}$ $Q_m = -9.2376$

Measurements and analyses of differential cross sections at $E(^3\text{He}) = 30\text{--}60$ MeV have been reported (1995MA57).

66. $^{19}\text{F}(\text{d}, ^6\text{Li})^{15}\text{N}$ $Q_m = -2.5394$

Differential cross sections at $E_d = 50$ MeV were reported (1990GO14).

67. $^{19}\text{F}(^3\text{He}, ^{16}\text{O})^6\text{Li}$ $Q_m = 4.0945$

Angular distributions have been measured at $E(^3\text{He}) = 11$ to 40.7 MeV involving $^6\text{Li}^*(0, 3.56)$ and various states of ^{16}O : see (1974AJ01, 1977AJ02). Differential cross sections have been reported for $E(^3\text{He}) = 66$ MeV (1991MA56).

68. $^{58}\text{Ni}(^6\text{Li}, \text{d})\text{X}$

Measurement of the tensor analyzing power made at $E(^6\text{Li}) = 34$ MeV (1978VE03) were analyzed to obtain the D - and S -state ratio for the $\langle \text{d}\alpha | ^6\text{Li} \rangle$ bound state overlap.

69. $^{138}\text{Ba}(^6\text{Li}, ^9\text{Li})$

Angular distributions measured for $E(^6\text{Li}) = 21\text{--}32$ MeV are reported by (1999MA16).

70. (a) $^{208}\text{Pb}(^6\text{Li}, ^6\text{Li})^{208}\text{Pb}$
 (b) $^{208}\text{Pb}(^6\text{Li}, \alpha\text{d})^{208}\text{Pb}$ $Q_m = -1.4743$

For reaction (a) differential cross sections were measured at $E(^6\text{Li}) = 25\text{--}60$ MeV and analyzed by the optical model (1994KE08, 1998KE03).

For reaction (b) measurements of triple differential cross sections for elastic breakup of 156 MeV ^6Li were reported in (1989HE28, 1989HE17, 1989RE1G). Data were analyzed on the basis of a diffractive disintegration approach. Breakup measurements at $E(^6\text{Li}) = 60$ MeV were reported in (1988HE16). See also reaction 56, and see the theoretical study of angular correlation of breakup fragments in (1989BA25).

^6Be
(Figs. 6 and 7)

GENERAL: References to articles on general properties of ^6Be published since the previous review (1988AJ01) are grouped into categories and listed, along with brief descriptions of each item, in the General Tables for ^6Be located on our website at (www.tunl.duke.edu/NuclData/General_Tables/6be.shtml).

- | | | |
|--|-----------------|---------------|
| 1. (a) $^3\text{He}(^3\text{He}, \gamma)^6\text{Be}$ | $Q_m = 11.4884$ | |
| (b) $^3\text{He}(^3\text{He}, \text{p})^5\text{Li}$ | $Q_m = 11.17$ | $E_b = 11.49$ |
| (c) $^3\text{He}(^3\text{He}, 2\text{p})^4\text{He}$ | $Q_m = 12.8596$ | |
| (d) $^3\text{He}(^3\text{He}, ^3\text{He})^3\text{He}$ | | |
| (e) $^3\text{He}(^3\text{He}, \text{pd})^3\text{He}$ | $Q_m = -5.4935$ | |

The yield of γ -rays to $^6\text{Be}^*(1.7)$ (reaction (a)) increases smoothly from 0.4 to 9.3 μb (assuming isotropy) for $0.86 < E(^3\text{He}) < 11.8$ MeV (90°). No transitions are observed to $^6\text{Be}_{\text{g.s.}}$.

Table 6.14: Energy levels of ^6Be

E_x (MeV \pm keV)	$J^\pi; T$	Γ_{cm}	Decay	Reactions
g.s.	$0^+; 1$	92 ± 6 keV	p, α	2, 3, 4
1.67 ± 50 ^a	$(2)^+; 1$	1.16 ± 0.06 MeV	p, α	1, 2, 3, 4
23	4^-	broad	γ , ^3He	1, 3
26	2^-	broad	^3He	1, 3
27	3^-	broad	^3He	1

^a See Table 6.8 in (1974AJ01).

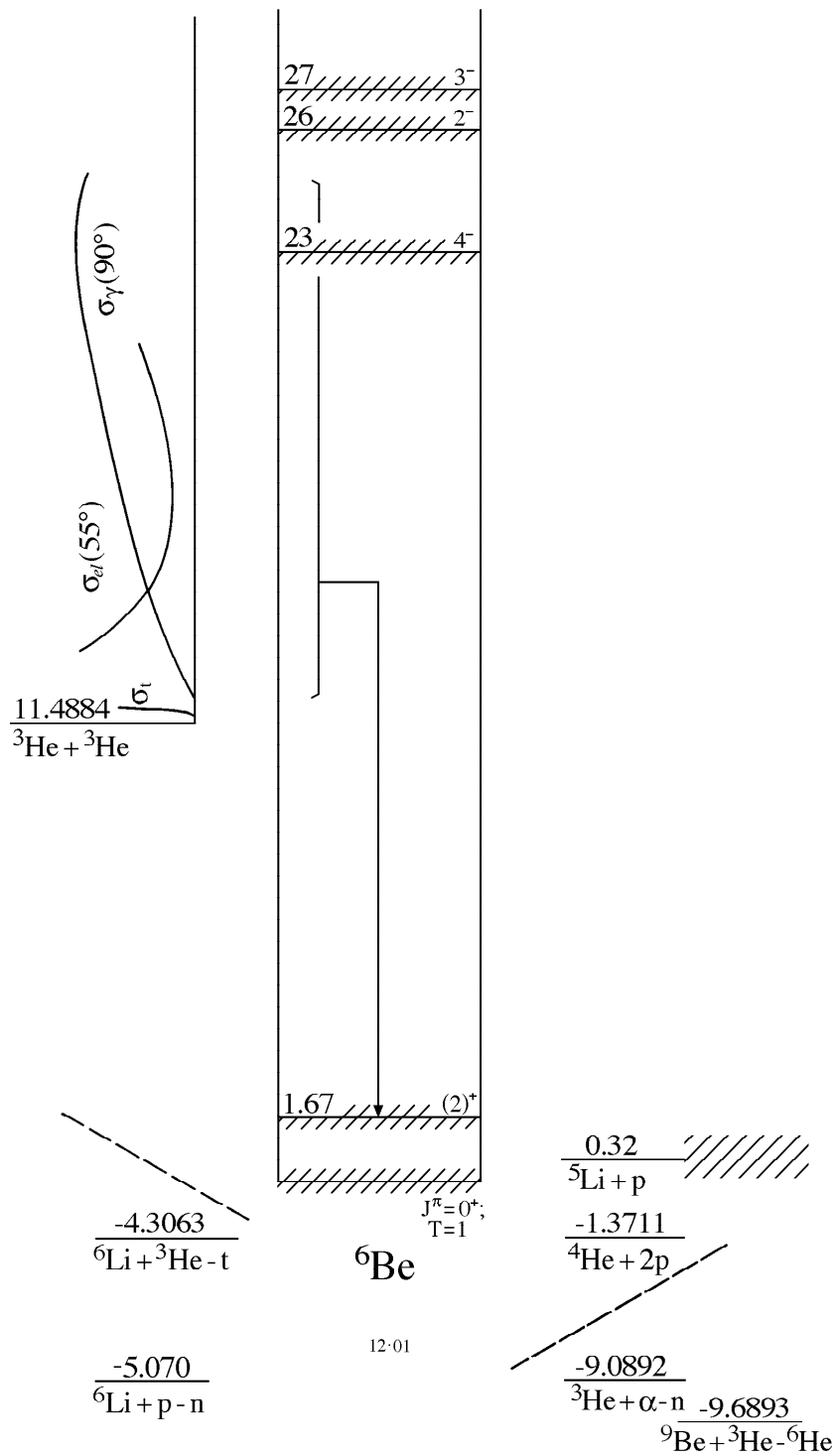

Figure 6: Energy levels of ${}^6\text{Be}$. For notation see Fig. 5.

[$\sigma < 0.01 \mu\text{b}$ at $E(^3\text{He}) = 1.4 \text{ MeV}$]. This is understood in terms of a direct capture of ^3He by ^3He in the singlet spin state and with zero angular momentum: the $0^+ \rightarrow 0^+$ γ -transition is forbidden. Reaction (a) is thus of negligible astrophysical importance compared to reaction (c): see (1979AJ01). The capture cross section from $E(^3\text{He}) = 12 \text{ MeV}$ to 27 MeV continues to increase smoothly with energy at first and then shows a broad structure centered at $E(^3\text{He}) = 23 \pm 1 \text{ MeV}$ [$E_x = 23.0 \pm 0.5 \text{ MeV}$], $\Gamma_{\text{cm}} \approx 5 \text{ MeV}$. This appears to be a ^{33}F cluster resonance which decays by an E1 transition to $^6\text{Be}^*(1.7)$. The γ -ray angular distributions are consistent with $J^\pi = 3^-$: see (1979AJ01). See also (1989IS1B). Thermonuclear reaction rates for this reaction calculated from evaluated data are presented in the compilation (1999AN35).

A_y has been measured for $E(^3\text{He}) = 14$ to 30 MeV [reaction (b)] by (1983KI10) using a polarized target. See also ^5Li .

Measurements of the total cross section for reaction (c) have been carried out for $E(^3\text{He}) = 60 \text{ keV}$ to 2.2 MeV [see (1979AJ01)] and for 36 to 685 keV (1987KR09). The measurements are consistent with a non-resonant reaction mechanism, at least down to $E_{\text{cm}} = 24.5 \text{ keV}$. Upper limits for $\omega\gamma$ for a resonance below that energy (and with E_{R} (cm) as low as 16.2 keV) [which might help explain the low observed flux of solar neutrinos], are given in (1987KR09). [It should be noted that a corresponding mirror state in ^6He has not been observed.] The best fit to the data is given by $S(0) = 5.57 \pm 0.31 \text{ MeV} \cdot \text{b}$ (1987KR09). See (1979AJ01) for the earlier work. See also (1966LA04, 1974AJ01). For work on astrophysical considerations see references cited in (1988AJ01), and see also the following work: thermonuclear reaction rates calculated from evaluated data (1988CA26, 1999AN35); dynamic screening (1988CA1J); neutrino astrophysics (1989BA2P); reaction rates (1989SC25); plasma fusion (1988PO1J); S factors, RGM (1989VA20); cross sections, extended elastic model (1990SC15); cross sections, microscopic study (1991TY01); phase shifts, generator coordinate method (1990KR12); astrophysical S -factor, potential model (1992WI09); cross sections, microscopic analysis (1994DE27); S factor, electron screening effects (1989BE08); and nucleosynthesis around black holes (1989JI1A). (1985SI12) report α -d correlation measurements at $E(^3\text{He}) = 13.6 \text{ MeV}$, which suggest the breakup of the diproton (^2He) into $^2\text{H} + e^+ + \nu$.

The elastic scattering (reaction (d)) has been studied for $E(^3\text{He}) = 3$ to 32 MeV and at 120 MeV . The excitation function shows a smooth monotonic behavior except for an anomaly at $E(^3\text{He}) = 25 \text{ MeV}$ in the $L = 3$ partial wave corresponding to a broad state in ^6Be at $E_x \approx 24 \text{ MeV}$. Polarization measurements have been carried out at $E(^3\text{He}) = 17.9$ to 32.9 MeV . A two level R -matrix analysis of the phase shifts ($L \leq 5$) suggests three broad F-wave states at $E_x \approx 23.4, 26.2$ and 26.7 MeV [$J^\pi = 4^-, 2^-$ and 3^- , respectively], in disagreement with the capture γ -ray results described above: see (1979AJ01). Calculations using the generator coordinate method have been reported for phase shifts ($E(^3\text{He}) < 5 \text{ MeV}$) (1990KR12), and for differential cross sections and astrophysical S factors ($E(^3\text{He}) = 2\text{--}6 \text{ MeV}$) (1994DE27). See also (1984AJ01) and (1986FO04).

A kinematically complete experiment (reaction (e)) has been performed at $E(^3\text{He}) = 120 \text{ MeV}$: large peaks were observed which appear to correspond to ^3He -d quasi-free scattering followed by p-d FSI: see (1984AJ01).

The total reaction cross sections $\sigma_R = 156.7 \pm 3.8$, 250 ± 14 and 296 ± 12 mb at $E(^3\text{He}) = 17.9$, 21.7 and 24.0 MeV (1987BR02) [see also for partial cross sections for the breakup reactions and for unpublished results for σ_R for $E(^3\text{He}) = 3.0$ to 17.9 MeV]. See also (1984AJ01) and references cited in (1988AJ01).

$$2. \ ^4\text{He}(^3\text{He}, n)^6\text{Be} \quad Q_m = -9.0892$$

Neutron groups to $^6\text{Be}^*(0, 1.7)$ have been observed at $E(^3\text{He}) = 19.4$ to 38.61 MeV: see Table 6.8 in (1974AJ01) for the parameters of the first-excited state. There is no evidence for other states of ^6Be with $E_x \leq 5$ MeV, nor for a state near the ^3He threshold at 11.5 MeV: see (1979AJ01).

$$3. \text{ (a) } ^6\text{Li}(p, n)^6\text{Be} \quad Q_m = -5.070$$

$$\text{ (b) } ^6\text{Li}(p, pn)^5\text{Li} \quad Q_m = -5.39$$

Neutron groups have been observed to $^6\text{Be}^*(0, 1.7)$ as has the ground-state threshold. The width of the ground state is 95 ± 28 keV. The parameters of $^6\text{Be}^*(1.7)$ are displayed in Table 6.8 of (1974AJ01). Angular distributions have been reported at $E_p = 8.3$ to 144 MeV [see (1979AJ01, 1984AJ01)] and at 800 MeV (1986KI12). The transverse spin transfer coefficient, $D_{NN}(0^\circ)$, at $E_p = 160$ MeV for the ground-state transition is -0.37 ± 0.04 in agreement with results in other light nuclei (1984TA07). See also ^7Be and references cited in (1988AJ01).

In more recent work, evidence for a proportionality between $\sigma_{pn}(0^\circ)$ and Gamow-Teller transition strengths were examined (1987TA13). See also (1989RA1G). Measurements are reported at: $E_p = 60$ –200 MeV [$D_{NN}(0^\circ)$ (1990RA08)]; $E_p = 256, 800$ MeV [double differential cross sections (1993ST06)]; $E_p = 186$ MeV [polarization observables (1993WAZX, 1993YAZZ, 1994RA23), quasi-free excitations (1994WA22, 1999WAZV), dipole excitations (1995YA12)]; $E_p = 392$ MeV [$\sigma(\theta)$, $A_y(\theta)$ (1994TO08)]; $E_p = 300, 400$ MeV [quasi-free excitations, $D_{NN}(0^\circ)$ (1994SA43)]; $E_p = 295$ MeV [spin-flip strength, $D_{NN}(0^\circ)$ (1995WA16)]; $E_p = 200$ MeV [$A_y(\theta)$ (1995WAZW)]; $E_p = 35$ MeV [$\sigma(\theta)$ (1996ORZZ, 1998OR1B)]; and $E_p = 280$ MeV [$\sigma(\theta)$, isospin-symmetry test (1990MI10)]. For recent applications see (1998HA24, 1998WA12). Calculations with a dynamical multicluster model are discussed in (1991DA08, 1993SH1G). See also the review of two-particle neutron halo nuclei in (1996DA31).

In reaction (b) some evidence has been reported at $E_p = 47$ MeV for sequential decay via $^6\text{Be}^*(15.5 \pm 2, 24 \pm 2)$: see (1979AJ01). See also (1988MIZX).

$$4. \ ^6\text{Li}(^3\text{He}, t)^6\text{Be} \quad Q_m = -4.3063$$

Triton groups have been observed to $^6\text{Be}^*(0, 1.7)$. The width of the ground state is 89 ± 6 keV. The parameters of the excited state are displayed in Table 6.8 of (1974AJ01). No other excited

states have been seen with $E_x < 13$ MeV. There is no evidence for a state near 11.5 MeV: see (1979AJ01). (1987BO39) have studied the decay of ${}^6\text{Be}^*(1.7)$ at $E({}^3\text{He}) = 38.7$ MeV: they report that the branching ratio for decay via the emission of ${}^2\text{He}$ [$T = 1, S = 0$] is 0.60 ± 0.15 : see also reactions 21 in ${}^6\text{He}$ and 38 in ${}^6\text{Li}$ and (1984BO49, 1985BO56, 1988BO1J). See also (1984AJ01), (1987DA31; theor.) and ${}^9\text{B}$ in (1988AJ01).

In more recent work, kinematically complete experiments for ${}^6\text{Li}({}^3\text{He}, t){}^6\text{Be}^*(0, 1.7) \rightarrow \alpha + p + p$ were reported in (1988BO38, 1989BO1N, 1989BO25, 1989BO42) and in (1992BO25, 1993BO38 [studied decay mechanism]). Measurements of differential cross sections at $E({}^3\text{He}) = 93$ MeV are described in (1994DOZW).

${}^6\text{B}, {}^6\text{C}$

(Not illustrated)

Not observed: see (1979AJ01, 1984AJ01, 1989GR06 [${}^6\text{Li}(\pi^+, \pi^-)$ at $E_{\pi^+} = 180, 240$ MeV], 93PO11 [properties of exotic light nuclei]) (1998SU18).

Table 6.15: Isospin triplet components ($T = 1$) in $A = 6$ nuclei ^a

${}^6\text{He}$		${}^6\text{Li}$		ΔE_x ^b (MeV)	${}^6\text{Be}$		ΔE_x ^c (MeV)
E_x (MeV)	J^π	E_x (MeV)	$J^\pi; T$		E_x (MeV)	J^π	
0	0^+	3.56	$0^+; 1$		0	0^+	
1.80	2^+	5.37	$2^+; 1$	+0.01	1.67	$(2)^+$	-0.13
5.6	$(2^+, 1^-, 0^+)$						
14.6	$(1^-, 2^-)$	17.99	$2^-; 1$	-0.17	26	2^-	11.4
		24.78	$3^-; 1$		27	3^-	
		24.89	$4^-; 1$		23	4^-	
		26.59	$2^-; 1$				

^a As taken from Tables 6.1, 6.4 and 6.14.

^b Defined as $E_x({}^7\text{Li}) - E_x({}^6\text{He}) - 3.56$ MeV.

^c Defined as $E_x({}^6\text{Be}) - E_x({}^6\text{He})$.

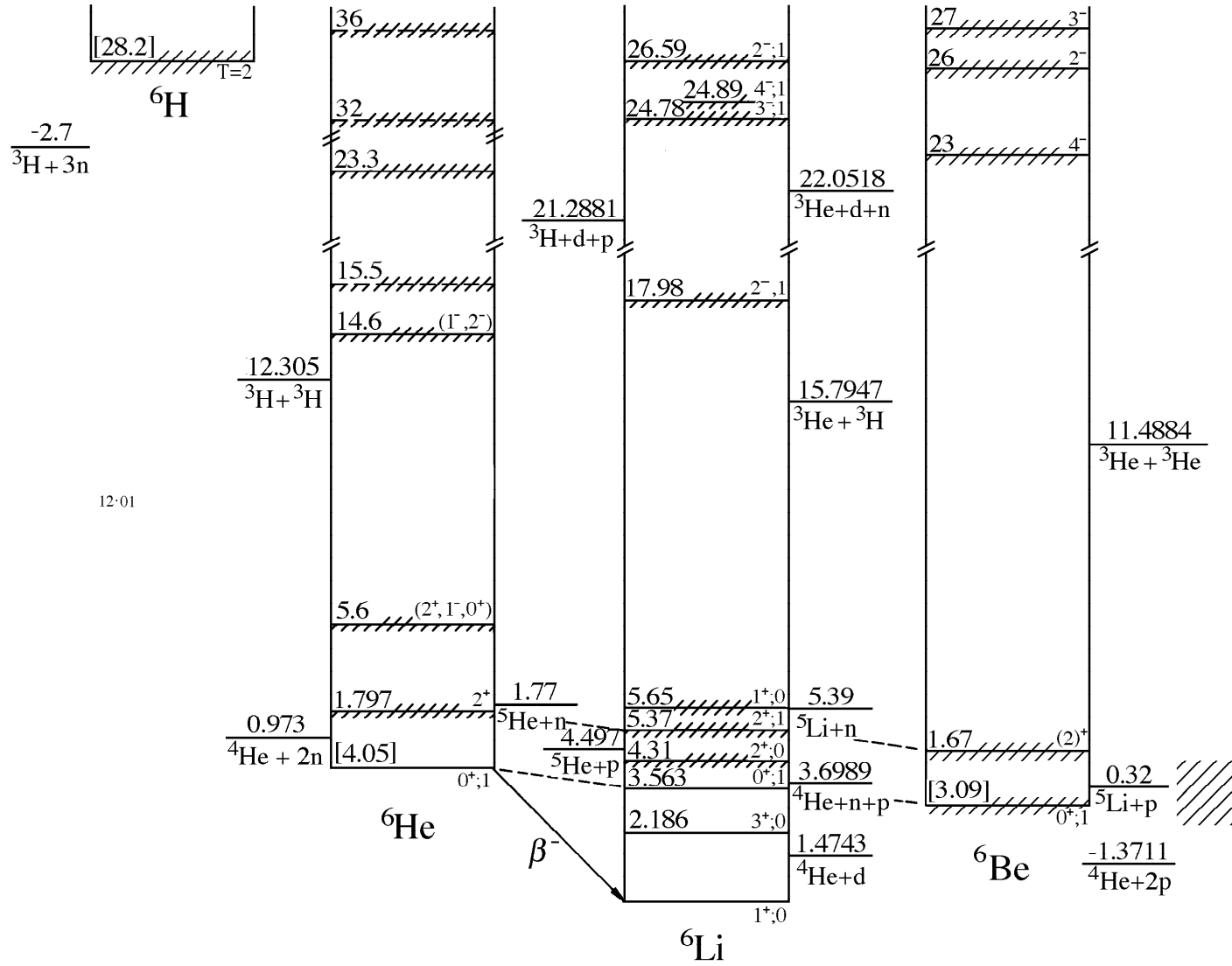

Figure 7: Isobar diagram, A = 6. For notation see Fig. 3.

References

(Closed 23 August 2001)

References are arranged and designated by the year of publication followed by the first two letters of the first-mentioned author's name and then by two additional characters. Most of the references appear in the National Nuclear Data Center files (Nuclear Science References Database) and have NNDC key numbers. Otherwise, TUNL key numbers were assigned with the last two characters of the form 1A, 1B, etc. In response to many requests for more informative citations, we have, when possible, included up to ten authors per paper and added the authors' initials.

- 1966LA04 T. Lauritsen and F. Ajzenberg-Selove, Nucl. Phys. 78 (1966) 1
- 1968BL10 S.L. Blatt, A.M. Young, S.C. Ling, K.J. Moon and C.D. Porterfield, Phys. Rev. 176 (1968) 1147
- 1968CO07 C.L. Cocke, Nucl. Phys. A110 (1968) 321
- 1969EI06 F. Eigenbrod, Z. Phys. 228 (1969) 337
- 1973VE09 E. Ventura, J.R. Calarco, W.E. Meyerhof and A.M. Young, Phys. Lett. B46 (1973) 364
- 1974AJ01 F. Ajzenberg-Selove and T. Lauritsen, Nucl. Phys. A227 (1974) 1
- 1977AJ02 F. Ajzenberg-Selove, Nucl. Phys. A281 (1977) 1
- 1977BR17 F.P. Brady, N.S.P. King, B.E. Bonner, M.W. McNaughton, J.C. Wang and W.W. True, Phys. Rev. C16 (1977) 31
- 1977VL01 R. Vlastou, J.B.A. England, O. Karban and S. Baird, Nucl. Phys. A292 (1977) 29
- 1978BO43 M.P. Bornand, G.R. Plattner, R.D. Viollier and K. Alder, Nucl. Phys. A294 (1978) 492
- 1978VE03 M.N. Vergnes, G. Rotbard, F. Guilbaut, D. Ardouin, C. Lebrun, E.R. Flynn, O.L. Hanson and S.D. Orbesen, Phys. Lett. B72 (1978) 447
- 1979AJ01 F. Ajzenberg-Selove, Nucl. Phys. A320 (1979) 1
- 1979BE38 J.C. Bergstrom, U. Deutschmann and R. Neuhausen, Nucl. Phys. A327 (1979) 439
- 1981RO02 R.G.H. Robertson, J.A. Nolen, Jr., T. Chapuran and R. Vodhanel, Phys. Rev. C23 (1981) 973
- 1982BE11 J.C. Bergstrom, S.B. Kowalski and R. Neuhausen, Phys. Rev. C25 (1982) 1156
- 1982KI11 J.C. Kim, J. Korean Phys. Soc. 15 (1982) 101
- 1983BA26 P.D. Barnes, B. Bassalleck, R.A. Eisenstein, G. Franklin, R. Grace, C. Maher, P. Pile, R. Rieder, J. Szymanski, W.R. Wharton et al., Nucl. Phys. A402 (1983) 397
- 1983BR23 M. Bruno, F. Cannata, M. D'Agostino, B. Jenny, W. Gruebler, V. Konig, P.A. Schmelzbach and P. Doleschall, Nucl. Phys. A407 (1983) 29
- 1983BR31 D.A. Bromley, Nucl. Phys. A400 (1983) 3c.

- 1983BR32 F. Brady, G.A. Needham, J.L. Romero, C.M. Castaneda, T.D. Ford, J.L. Ullmann and M.L. Webb, *Phys. Rev. Lett.* 51 (1983) 1320
- 1983CA13 G. Calvi, M. Lattuada, F. Riggi, C. Spitaleri, D. Vinciguerra and D. Miljanic, *Lett. Nuovo Cim.* 37 (1983) 279
- 1983CO1E H. Conde, T. Andersson, L. Nilsson and C. Nordborg, in *Antwerp (1983)* 447; *Phys. Abs.* (1984) 43476
- 1983DA22 J.H. Dave and C.R. Gould, *Phys. Rev. C*28 (1983) 2212
- 1983DO10 V.N. Dobrikov, O.F. Nemets, A.S. Gass and A.A. Shvedov, *Izv. Akad. Nauk. SSSR, Ser. Fiz.* 47 (1983) 943; *Bull. Acad. Sci. USSR Phys. Ser.* 47 (1983) 114
- 1983FU11 Y. Fujiwara and Y.C. Tang, *Phys. Rev. C*28 (1983) 1869
- 1983GLZZ C.W. Glover, C.C. Foster, P. Schwandt, J.R. Comfort, J. Rapaport, T.N. Taddeucci, D. Wong, J. Seubert and G. Wagner, *Bull. Amer. Phys. Soc.* 28 (1983) 996, EC3
- 1983GO06 O.K. Gorpnich, E.P. Kadkin, S.N. Kondratev, Yu.N. Lobach, M.V. Pasechnik, L.S. Saltykov and V.V. Tokarevsky, *Izv. Akad. Nauk. SSSR Ser. Fiz.* 47 (1983) 185; *Bull. Acad. Sci. USSR Phys. Ser.* 47 (1983) 179
- 1983IS10 M. Ishikawa, S. Seki, K. Furuno, Y. Tagishi, M. Sawada, T. Sugiyama, K. Matsuda, T. Murayama, N.X. Dai, J. Sanada et al., *Phys. Rev. C*28 (1983) 1884
- 1983JA13 B. Jakobsson, *Phys. Scr.* T5 (1983) 207
- 1983JE03 B. Jenny, W. Gruebler, V. Konig, P.A. Schmelzbach and C. Schweizer, *Nucl. Phys.* A397 (1983) 61
- 1983KI10 U. Kirchner, R. Beckmann, U. Holm and H.-G. Korber, *Nucl. Phys.* A405 (1983) 159
- 1983KU17 N. Kumar, *Nucl. Phys.* A410 (1983) 50
- 1983LE26 Y. Le Bornec, F. Hibou, L. Bimbot, T. Hennino, J.C. Jourdain, F. Reide, B. Tatischeff, N. Willis, E. Aslanides, G. Bergdolt et al., *Phys. Lett.* B133 (1983) 149
- 1983LO10 G.J. Lolos, R.R. Johnson, P. Couvert, J. McKenna, R. Myers, I. Spadinger and P. Lorrain, *Phys. Lett.* B126 (1983) 20
- 1983LY04 E.B. Levshin, K.G. Sailer and A.D. Foursat, *Yad. Fiz.* 38 (1983) 633; *Sov. J. Nucl. Phys.* 38 (1983) 377
- 1983NO08 E. Norbeck, P.T. Wu, C.R. Chen and R.R. Carlson, *Phys. Rev. C*28 (1983) 1140
- 1983OT02 K. Otozai, T. Sekine, R. Arakawa, K. Hata, T. Saito and H. Baba, *Z. Phys.* A311 (1983) 303
- 1983PO1B Poppe et al., *AIP Conf. Proc.* 97 (1983) 226
- 1983POZX C.H. Poppe, D. Rowley and F.S. Dietrich, *Bull. Amer. Phys. Soc.* 28 (1983) 969, AD8
- 1983RO12 R.G.H. Robertson and B.A. Brown, *Phys. Rev. C*28 (1983) 443
- 1983RU09 K. Rusek, Z. Moroz, R. Caplar, P. Egelhof, K.-H. Mobius, E. Steffens, I. Koenig, A. Weller and D. Fick, *Nucl. Phys.* A407 (1983) 208

- 1983SH1J K. Shibata and S. Shirato, *J. Phys. Soc. Jpn.* 52 (1983) 3748
- 1983VI03 M.F. Vineyard, J. Cook and K.W. Kemper, *Nucl. Phys. A*405 (1983) 429
- 1984AJ01 F. Ajzenberg-Selove, *Nucl. Phys. A*413 (1984) 1
- 1984AK01 A.I. Akhiezer and M.P. Rekalov, *Dokl. Akad. Nauk. SSSR* 274 (1984) 1079; *Sov. Phys. Dokl.* 24 (1984) 121
- 1984AL08 D.V. Aleksandrov, E.A. Ganza, Yu.A. Glukhov, B.G. Novatsky, A.A. Ogloblin and D.N. Stepanov, *Yad. Fiz.* 39 (1984) 513; *Sov. J. Nucl. Phys.* 39 (1984) 323
- 1984AR17 N. Arena, S. Cavallaro, A.S. Figuera, P. D'Agostino, G. Fazio, G. Giardina and F. Mezzanares, *Lett. Nuovo Cim.* 41 (1984) 59
- 1984BA19 I.Ya. Barit, L.S. Dulkova, E.V. Kuznetsova and N.M. Sobolevsky, *Izv. Akad. Nauk. SSSR Ser. Fiz.* 48 (1984) 380; *Bull. Acad. Sci. USSR Phys. Ser.* 48 (1984) 159
- 1984BA53 J. Bang, F.A. Gareev, S.A. Goncharov and G.S. Kazacha, *Nucl. Phys. A*429 (1984) 330.
- 1984BL21 L.D. Blokhintsev, A.M. Mukjamedzhanov and A.N. Safronov, *Fiz. Elem. Chastits At. Yadra* 15 (1984) 1296; *Sov. J. Part. Nucl* 15 (1984) 580
- 1984BO49 O.V. Bochkarev, A.A. Korshennikov, E.A. Kuzmin, I.G. Mukha, A.A. Ogloblin, L.V. Chulkov and G.B. Yankov, *Pisma Zh. Eksp. Teor. Fiz.* 40 (1984) 204; *JETP Lett. (USSR)* 40 (1984) 969
- 1984BR03 F.P. Brady, G.A. Needham, J.L. Ullmann, C.M. Castaneda, T.D. Ford, N.S.P. King, J.L. Romero, M.L. Webb, V.R. Brown and C.H. Poppe, *J. Phys.* G10 (1984) 363.
- 1984BR04 J. Brzychczyk, L. Freindl, K. Grotowski, Z. Majka, S. Micek, R. Planeta, M. Albinska, J. Buschmann, H. Klewe-Nebenius, H.J. Gils et al., *Nucl. Phys. A*417 (1984) 174
- 1984BU01 V.V. Burov, V.M. Dubovik, S.G. Kadmsky, Yu.M. Tchuvilsky and L.A. Tosunyan, *J. Phys.* G10 (1984) L21
- 1984CH16 E. Chiavassa, S. Costa, G. Dellacasa, N. De Marco, M. Gallio, A. Musso, E. Aslanides, P. Fassnacht, F. Hibou, T. Bressani et al., *Nucl. Phys. A*422 (1984) 621
- 1984DE53 P. De Bievre, M. Gallet, N.E. Holden and I.L. Barnes, *J. Phys. Chem. Ref. Data* 13 (1984) 809
- 1984DO20 T.W. Donnelly and I. Sick, *Rev. Mod. Phys.* 56 (1984) 461
- 1984DY01 N. Dytlewski, S.A. Siddiqui and H.H. Thies, *Nucl. Phys. A*430 (1984) 214
- 1984FE1A Ferch et al., *INDC (CCP)-221/L* (1984) 18
- 1984GE05 J.-F. Germond and C. Wilkin, *J. Phys.* G10 (1984) 745
- 1984GR20 K. Grotowski, Z. Majka, R. Planeta, M. Szczodrak, Y. Chan, G. Guarino, L.G. Moretto, D.J. Morrissey, L.G. Sobotka, R.G. Stokstad, I. Tserruya et al., *Phys. Rev.* C30 (1984) 1214

- 1984KI16 R.R. Kiziah, M.D. Brown, C.J. Harvey, D.S. Oakley, D.P. Saunders, P.A. Seidl, C.F. Moore, W.B. Cottingham, R.W. Garnett, S.J. Greene et al., Phys. Rev. C30 (1984) 1643.
- 1984KO25 I. Koenig, D. Fick, S. Kossionides, P. Egelhof, K.-H. Mobius and E. Steffens, Z. Phys. A318 (1984) 135
- 1984KR1B A.V. Kravtsov, N.P. Popov and G.E. Solvakin, Pisma Zh. Eksp. Teor. Fiz. 40 (9184) 124; JETP Lett. (USSR) 40 (1984) 875
- 1984LA19 M. Lattuada, F. Riggi, C. Spitaleri, D. Vinciguerra, G. Vourvopoulos, X. Aslanoglu and D. Miljanic, Phys. Rev. C30 (1984) 531
- 1984NA17 V.S. Nadezhdin, N.I. Petrov, V.I. Satarov and A.M. Rozanova, Yad. Fiz. 40 (1984) 27; Sov. J. Nucl. Phys. 40 (1984) 17
- 1984NE1A Nemets, Rudchik and Chuvilski, in Alma Ata (1984) 334
- 1984NI01 H. Nishioka, J.A. Tostevin, R.C. Johnson and K.-I. Kubo, Nucl. Phys. A415 (1984) 230
- 1984PA1B Pasechnik et al., in Alma Ata (1984) 288
- 1984RO04 R.G.H. Robertson, P. Dyer, R.C. Melin, T.J. Bowles, A.B. McDonald, G.C. Ball, W.G. Davies and E.D. Earle, Phys. Rev. C29 (1984) 755
- 1984SA39 L. Satta, J. Duflo, F. Plouin, P. Picozza, L. Goldzahl, J. Banaigs, R. Frascaria, F.L. Fabbri, A. Codino, J. Berge et al., Phys. Lett. B139 (1984) 263
- 1984SHZJ A.A. Shvedov, V.N. Dobrikov and O.F. Nemets, in Alma-Ata (1984) 332
- 1984SM04 G.R. Smith, J.R. Shepard, R.L. Boudrie, R.J. Peterson, G.S. Adams, T.S. Bauer, G.J. Igo, G. Pauletta, C.A. Whitten, Jr., A. Wriekat et al., Phys. Rev. C30 (1984) 593.
- 1984TA07 T.N. Taddeucci, T.A. Carey, C. Gaarde, J. Larsen, C.D. Goodman, D.J. Horen, T. Masterson, J. Rapaport, T.P. Welch and E. Sugarbaker, Phys. Rev. Lett. 52 (1984) 1960
- 1984TU02 M. Turk and B. Antolkovic, Nucl. Phys. A431 (1984) 381
- 1984UM04 K. Umeda, T. Yamaya, T. Suehiro, K. Takimoto, R. Wada, E. Takada, S. Shimoura, A. Sakaguchi, S. Murakami, M. Fukada et al., Nucl. Phys. A429 (1984) 88
- 1984VI01 M.F. Vineyard, K.W. Kemper and J. Cook, Phys. Lett. B142 (1984) 249
- 1984VI02 M.F. Vineyard, J. Cook, K.W. Kemper and M.N. Stephens, Phys. Rev. C30 (1984) 916
- 1984WA09 R.E. Warner, R.S. Wakeland, J.-Q. Yang, D.L. Friesel, P. Schwandt, G. Caskey, A. Galonsky, B. Remington and A. Nadasen, Nucl. Phys. A422 (1984) 205
- 1984WA18 M.W. Wade, M.K. Brussel, L.J. Koester, Jr. and J.H. Smith, Phys. Rev. Lett. 53 (1984) 2540

- 1985AJ01 F. Ajzenberg-Selove, Nucl. Phys. A433 (1985) 1; Erratum Nucl. Phys. A449 (1986) 155.
- 1985AK1B I. Akhiezer and M.P. Rekalov, Dokl. Akad. Nauk. SSSR 280 (1985) 83; Sov. Phys. Dokl. (USA) 30 (1985) 45
- 1985AL1G Aleksandrov et al., Questions in At. Phys. and in Tech., USSR (1985) 3
- 1985BAYZ I.Ya. Barit, Yu.G. Balashko, L.S. Dulkova and S.V. Zuev, Program and Theses, Proc. 35th Ann. Conf. Nucl. Spectrosc. Struct. At. Nuclei, Leningrad (1985) p. 307
- 1985BE30 S.L. Belostotsky, S.S. Volkov, A.A. Vorobyev, Yu.V. Dotsenko, L.G. Kudin, N.P. Kuropatkin, O.V. Miklukho, V.N. Nikulin and O.E. Prokofyev, Yad. Fiz. 41 (1985) 1425; Sov. J. Nucl. Phys. 41 (1985) 903
- 1985BO55 O.V. Bochkarev, A.A. Korshennikov, E.A. Kuzmin, I.G. Mukha, A.A. Ogloblin, L.V. Chulkov and G.B. Yankov, Pisma Zh. Eksp. Teor. Fiz. 42 (1985) 303; JETP Lett. (USSR) 42 (1985) 374
- 1985BO56 O.V. Bochkarev, A.A. Korshennikov, E.A. Kuzmin, I.G. Mukha, A.A. Ogloblin, L.V. Chulkov and G.B. Yankov, Pisma Zh. Eksp. Teor. Fiz. 42 (1985) 305; JETP Lett. (USSR) 42 (1985) 377
- 1985CA41 G.R. Caughlan, W. A. Fowler, M.J. Harris and B.A. Zimmerman, At. Data Nucl. Data Tables 32 (1985) 197
- 1985CH37 S. Chiba, M. Baba, H. Nakashima, M. Ono, N. Yabuta, S. Yukinori and N. Hirakawa, J. Nucl. Sci. Tech. (Tokyo) 22 (1985) 771
- 1985CO09 J. Cook and K.W. Kemper, Phys. Rev. C31 (1985) 1745
- 1985CU04 A. Cunsolo, A. Foti, G. Imme, G. Pappalardo, G. Raciti, F. Rizzo and N. Saunier, Nuovo Cim. A85 (1985) 343.
- 1985DA29 V. D'Amico, G. Fazio, S. Femino, G. Giardina, A. Italiano and F. Mezzaneres, Can. J. Phys. 63 (1985) 1438
- 1985DE05 G. D'Erasmus, V. Variale and A. Pantaleo, Phys. Rev. C31 (1985) 656
- 1985DE17 E. Descroix, M. Bedjidian, J.Y. Grossiord, A. Guichard, M. Gusakov, M. Jacquin, J.R. Pizzi and G. Bagieu, Nucl. Phys. A438 (1985) 112.
- 1985DO16 Yu.V. Dotsenko and V.E. Starodubsky, Yad. Fiz. 42 (1985) 107; Sov. J. Nucl. Phys. 42 (1985) 66.
- 1985FR01 R. Franke, K. Kochskemper, B. Steinheuer, K. Wingender, W. Von Witsch and H. Machner, Nucl. Phys. A433 (1985) 351
- 1985GO1G Gorionov et al., in Leningrad (1985) 310
- 1985JA16 N. Jarmie and R.E. Brown, Nucl. Instrum. Meth. Phys. Res. B10-11 (1985) 405
- 1985JE04 B. Jenny, W. Gruebler, V. Konig and P.A. Schmelzbach, Nucl. Phys. A444 (1985) 93

- 1985KO29 Yu.E. Kozyr, V.I. Medvedev, Yu.N. Pavlenko and V.M. Pugach, *Izv. Akad. Nauk. SSSR, Ser. Fiz.* 49 (1985) 1026; *Bull. Acad. Sci. USSR Phys. Ser.* 49 (1985) 179
- 1985KR13 J.J. Kraushaar, P.D. Kunz, J.H. Mitchell, J.M. Cameron, D.A. Hutcheon, R.P. Liljestr nd, W.J. McDonald, C.A. Miller, W.C. Olsen, J.R. Tinsley et al., *Phys. Rev. C* 32 (1985) 1083
- 1985LU08 R.C. Luhn, S. Sen, N.O. Gaiser, S.E. Darden and Y. Koike, *Phys. Rev. C* 32 (1985) 11
- 1985MAZG B.S. Mazitov and E.N. Rasulov, in *Leningrad* (1985) 298
- 1985MC05 B.J. McParland, E.G. Auld, P. Couvert, G.L. Giles, G. Jones, W. Ziegler, X. Aslanoglou, G.M. Huber, G.J. Lolos, S.I.H. Naqvi et al., *Phys. Lett.* B156 (1985) 47
- 1985ME02 A.C. Merchant and N. Rowley, *Phys. Lett.* B150 (1985) 35
- 1985MI05 S. Micek, Z. Majka, H. Rebel, H.J. Gils and H. Klewe-Nebenius, *Nucl. Phys.* A435 (1985) 621
- 1985MOZZ A. Mondragon and E. Hernandez, *Bull. Amer. Phys. Soc.* 30 (1985) 700, AE4
- 1985NI01 K. Nisimura, H. Shimizu, K. Imai, T. Ichihara, N. Matsuoka, K. Hatanaka, H. Sakai, T. Saito, K. Hosono, M. Kondo et al., *Nucl. Phys.* A432 (1985) 378
- 1985NO1A Norbeck and Lin, *Bull. Amer. Phys. Soc.* 30 (1985) 1248
- 1985OS02 H. Oswald, M. Buballa, J. Helten, M. Karus, B. Laumann, R. Melzer, P. Niessen, G. Rauprich, J. Schulte-Uebbing, H. Paetz gen. Schieck and Y. Koike, *Nucl. Phys.* A435 (1985) 77
- 1985PA04 M.V. Pasechnik, L.S. Saltykov, E.P. Kadkin, I.I. Loshchakov and A.I. Vdovin, *Izv. Akad. Nauk. SSSR, Ser. Fiz.* 49 (1985) 58; *Bull. Acad. Sci. USSR Phys. Ser.* 49 (1985) 61
- 1985PA1B Pasechnik, in *Leningrad* (1985) 265
- 1985PAZL M.V. Pasechnik, L.S. Saltykov, E.P. Kadkin, I.I. Loshchakov and A.I. Vdovin, in *Leningrad* (1985) 296
- 1985PO10 N.A.F.M. Poppelier, L.D. Wood and P.W.M. Glaudemans, *Phys. Lett.* B157 (1985) 120.
- 1985RE1A Repenko et al., in *Leningrad* (1985) 342
- 1985SA36 Y. Sakuragi, M. Kamimura, S. Micek, H. Rebel and H.J. Gils, *Z. Phys.* A322 (1985) 627
- 1985SE17 M.R. Sene, I. Anthony, D. Branford, A.G. Flowers, A.C. Shotter and C.H. Zimmerman, *Nucl. Phys.* A442 (1985) 215
- 1985SI12 B.K. Sinha, A.M. Nachabe, P. Bricault, J. Pouliot, L. Potvin, R. Roy and R.J. Slobodrian, *Z. Phys.* A321 (1985) 381
- 1985ST1A Stibunov, in *Leningrad* (1985) 341

- 1985TA13 I. Tanihata, H. Hamagaki, O. Hashimoto, S. Nagamiya, Y. Shida, N. Yoshikawa, O. Yamakawa, K. Sugimoto, T. Kobayashi, D.E. Greiner et al., Phys. Lett. B160 (1985) 380
- 1985TA18 I. Tanihata, H. Hamagaki, O. Hashimoto, Y. Shida, N. Yoshikawa, K. Sugimoto, O. Yamakawa, T. Kobayashi and N. Takahashi, Phys. Rev. Lett. 55 (1985) 2676
- 1985VI03 M.F. Vineyard, J. Cook and K.W. Kemper, Phys. Rev. C31 (1985) 879
- 1985WA25 R.E. Warner, J.-Q. Yang, D.L. Friesel, P. Schwandt, G. Caskey, A. Galonsky, B. Remington, A. Nadasen, N.S. Chant, F. Khazaie et al., Nucl. Phys. A443 (1985) 64
- 1985WO11 L.W. Woo, K. Kwiatkowski, S.H. Zhou and V.E. Viola, Phys. Rev. C32 (1985) 706
- 1986AJ04 F. Ajzenberg-Selove, Nucl. Phys. A460 (1986) 1
- 1986AK1C A.I. Akhiezer and M.P. Rekalov, Dokl. Akad. Nauk SSSR 287 (1986) 1365; Sov. Phys. Dokl. 31 (1986) 332
- 1986AN04 L.E. Antonuk, D. Bovet, E. Bovet, Y. De Coulon, J.-P. Egger, F. Goetz, P. Gretillat, C. Lunke, E. Schwarz, G.S. Adams et al., Nucl. Phys. A451 (1986) 741
- 1986AN26 B. Antolkovic, G. Paic and K. Kadija, Few-Body Syst. 1 (1986) 159
- 1986AV01 G.V. Avakov, L.D. Blokhintsev, A.M. Mukhamedzhanov and R. Yarmukhamedov, Yad. Fiz. 43 (1986) 824; Sov. J. Nucl. Phys. 43 (1986) 524
- 1986BA1R G. Baur, C.A. Bertulani and H. Rebel, in Heidelberg (1986) 980; Phys. Abs. 49378 (1987)
- 1986BA2G Barlamov, Ishkanov, Chernyaev and Eramzhian, in Kharkov (1986) 345
- 1986BE35 A.V. Belozyorov, C. Borcea, Z. Dlouhy, A.M. Kalinin, R. Kalpakchieva, Nguyen Hoai Chau, Yu.Ts. Oganessian and Yu.E. Penionzhkevich, Nucl. Phys. A460 (1986) 352
- 1986BR1N M. Bruno, F. Cannata, M.D. D'Agostino, M. Frisoni, H. Herman, B. Vuaridel, V. Konig, W. Gruebler, K. Elsener, P.A. Schemlzbach et al., Few-Body Syst. Suppl. 1 (1986) 211
- 1986BR20 R.E. Brown and N. Jarmie, Radiat. Eff. 92 (1986) 45
- 1986BR31 V.N. Bragin, N.T. Burtebaev, A.D. Dujsebaev, G.N. Ivanov, S.B. Sakuta, V.I. Chuev and L.V. Chulkov, Yad. Fiz. 44 (1986) 312; Sov. J. Nucl. Phys. 44 (1986) 198
- 1986BU07 V.V. Burov, V.M. Dubovik, S.G. Kadmsky, Yu.M. Tchuvilsky and L.A. Tosunyan, J. Phys. G12 (1986) 509
- 1986CL1B N.M. Clarke, P.J. Simmons, K.I. Pearce, S. Roman, A. Farooq and G. Rai, J. Phys. Soc. Jpn. Suppl. 55 (1986) 756
- 1986DO1K P. Doleschall, C. Chandler, M. Bruno, F. Cannata, M. D'Agostino and M.L. Fiandri, Few-Body Syst. Suppl. 1 (1986) 206

- 1986EN05 R. Ent, H.P. Blok, J.F.A. van Hienen, G. van der Steenhoven, J.F.J. van den Brand, J.W.A. den Herder, E. Jans, P.H.M. Keizer, L. Lapikas, E.N.M. Quint et al., Phys. Rev. Lett. 57 (1986) 2367
- 1986EV1A Evseev, Buki, Likhachev and Shevchenko, in Kharkov (1986) 350
- 1986FO04 D. Fox, D.A. Cebra, Z.M. Koenig, P. Ugorowski and G.D. Westfall, Phys. Rev. C33 (1986) 1540
- 1986GL07 I.V. Glavanakov, V.N. Eponeshnikov, Yu.F. Krechetov, G.M. Radutsky and V.A. Tryasuchev, Phys. Lett. B178 (1986) 155
- 1986GLZU Yu.A. Glukhov, E.I. Koshchy, N.S.Lutsay, Yu.G. Mashkarov, E.Yu. Nikolsky, A.T. Rudchik, S.B. Sakuta and K.F. Ustimenkov, in Kharkov (1986) 371
- 1986GO1M B.I. Goryachev, Sov. J. Nucl. Phys. 44 (1986) 252
- 1986GO23 S.A. Goncharov, Yu.I. Denisov, A.M. Mukhamedzhanov, E.A. Romanovsky, G.E. Valiev, I.R. Gulamov, T. Iskhakov, G. Ni, N.K. Timofeyuk, R. Yarmukhamedov et al., Yad. Fiz. 44 (1986) 303; Sov. J. Nucl. Phys. 44 (1986) 191
- 1986GR1D W. Gruebler, V. Konig, P.A. Schmelzbach, R.E. White, B. Vuaridel, C. Forstner, D. Singy, M. Bittcher and J. Ulbricht, J. Phys. Soc. Jpn. Suppl. 55 (1986) 884
- 1986HA27 H.J. Hauser, M. Walz, F. Weng, G. Staudt and P.K. Rath, Nucl. Phys. A456 (1986) 253
- 1986HAZR L.F. Hansen, J. Rapaport, X. Wang and F.A. Barrios, Bull. Amer. Phys. Soc. 31 (1986) 1237, ED3
- 1986JA02 L. Jarczyk, B. Kamys, Z. Rudy, A. Strzalkowski, B. Styczen, G.P.A. Berg, A. Magiera, J. Meissburger, W. Oelert, P. Von Rossen et al., Nucl. Phys. A448 (1986) 1
- 1986JA14 L. Jarczyk, B. Kamys, Z. Rudy, A. Strzalkowski, B. Styczen, G.P.A. Berg, A. Magiera, J. Meissburger, W. Oelert, P. von Rossen et al., Nucl. Phys. A459 (1986) 52
- 1986JA1E Jarime, Preprint LA-UR-86-3705 (1986)
- 1986KA26 K. Kadija and G. Paic, Phys. Rev. C34 (1986) 380
- 1986KI12 N.S.P. King, P.W. Lisowski, G.L. Morgan, P.N. Craig, R.G. Jeppesen, D.A. Lind, J.R. Shepard, J.L. Ullmann, C.D. Zafiratos, C.D. Goodman et al., Phys. Lett. B175 (1986) 279
- 1986KO1K H.-G. Korber, R. Beckmann, U. Holm and A. Lindner, J. Phys. Soc. Jpn. Suppl. 55 (1986) 632
- 1986KO1M V. Konig, P.A. Schmelzbach, W. Gruebler, Ch. Forstner, M. Bittcher, J. Ulbricht, B. Vuaridel and D. Singy, J. Phys. Soc. Jpn. Suppl. 55 (1986) 886
- 1986LA22 K. Langanke, Nucl. Phys. A457 (1986) 351

- 1986LA27 K. Langanke and C. Rolfs, *Z. Phys.* A325 (1986) 193
- 1986LI1F Likhachev et al., in *Kharkov* (1986) 349
- 1986LIZP P.J. Lindstrom, M.E. Baumgartner, E. Beale, F. Bieser, M. Bronson, D.E. Greiner, C.P. McParland, D.L. Olson, H.J. Crawford, J. Engelage et al., *Bull. Amer. Phys. Soc.* 31 (1986) 888, KI5
- 1986MA19 J.F. Mateja, A.D. Frawley, L.C. Dennis and K. Sartor, *Phys. Rev.* C33 (1986) 1649
- 1986MC11 B.J. McParland, E.G. Auld, P. Couvert, G.L. Giles, G. Jones, W. Ziegler, X. Aslanoglou, G.M. Huber, G.J. Lolos, S.I.H. Naqvi et al., *Nucl. Phys.* A456 (1986) 629
- 1986ME13 T. Mertelmeier and H.M. Hofmann, *Nucl. Phys.* A459 (1986) 387
- 1986MI1E K. Miyagawa, Y. Koike, T. Ueda, T. Sawada and S. Takagi, *J. Phys. Soc. Jpn. Suppl.* 55 (1986) 890
- 1986MO1E Z. Moroz, *J. Phys. Soc. Jpn. Suppl.* 55 (1986) 221
- 1986MOZQ A. Mondragon and E. Hernandez, in *Harrogate* (1986) B10, 36
- 1986PE05 J.P. Perroud, A. Perrenoud, J.C. Alder, B. Gabioud, C. Joseph, J.F. Loude, N. Morel, M.T. Tran, E. Winkelmann, H. Von Fellenberg et al., *Nucl. Phys.* A453 (1986) 542
- 1986PF1A H.G. Pfutzner, A.L. Li, K. Murphy, C.R. Howell, M.L. Roberts, I. Slaus, R.L. Walter, M. Herman and H.M. Hofmann, *J. Phys. Soc. Jpn. Suppl.* 55 (1986) 556
- 1986RA1C C. Rai, C. Blyth and A. Farooq, *J. Phys. Soc. Jpn. Suppl.* 55 (1986) 1010
- 1986RI01 R. Rieder, P.D. Barnes, B. Bassalleck, R.A. Eisenstein, G. Franklin, R. Grace, C. Maher, P. Pile, J. Szymanski, W.R. Wharton et al., *Phys. Rev.* C33 (1986) 614
- 1986ROZK A. Roy, R.K. Bhowmik, C.V.K. Baba, M.G. Betigeri, R. Mythili and A.K. Jain, in *Harrogate* (1986) C225, 412
- 1986SC28 C.J.S. Scholz, L. Ricken and E. Kuhlmann, *Z. Phys.* A325 (1986) 203
- 1986SH14 K. Shoda, M. Torikoshi, O. Sasaki, S. Toyama, T. Kobayashi, A. Kagaya and H. Tsubota, *Phys. Rev.* C33 (1986) 2179
- 1986SHZP T. Shimoda, N. Ikeda, A. Nakamura, S. Shimoura, K. Katori, T. Fukuda and H. Ogata, in *Harrogate* (1986) C159, 346
- 1986TA06 H. Taneichi, H. Ueno, K. Shoda, Y. Kawazoe and T. Tsukamoto, *Nucl. Phys.* A448 (1986) 315
- 1986VA23 C.P.M. van Engelen, E.A. Bakkum, R.J. Meijer and R. Kamermans, *Nucl. Phys.* A457 (1986) 375.
- 1986VUZZ B. Vuaridel, W. Gruebler, V. Konig, P.A. Schmelzbach, K. Elsener, J. Ulbricht, D. Singy, Ch. Forstner, M. Bittcher, M. Bruno et al., in *Harrogate* (1986) 258, C71
- 1986YA12 T. Yamaya, J.I. Hirota, K. Takimoto, S. Shimoura, A. Sakaguchi, S. Kubono, M. Sugitani, S. Kato, T. Suehiro and M. Fukada, *Phys. Rev.* C34 (1986) 2369

- 1987AB09 S.N. Abramovich, L.A. Morkin, V.I. Serov and Yu.V. Strelnikov, *Izv. Akad. Nauk SSSR Ser. Fiz.* 51 (1987) 930; *Bull. Acad. Sci. USSR Phys. Ser.* 51 (1987) 92
- 1987AJ02 F. Ajzenberg-Selove, *Nucl. Phys.* A475 (1987) 1
- 1987AL23 D.V. Aleksandrov, Yu.A. Glukhov, B.G. Novatsky, E.Yu. Nikolsky, S.B. Sakuta and D.N. Stepanov, *Yad. Fiz.* 46 (1987) 385; *Sov. J. Nucl. Phys.* 46 (1987) 197
- 1987AR13 A.E. Aravantinos and A.C. Xenoulis, *Phys. Rev.* C35 (1987) 1746
- 1987AS06 E. Aslanides, D.M. Drake, J.C. Peng, D. Garreta, P. Birien, G. Bruge, H. Catz, A. Chaumeaux, S. Janouin, D. Legrand et al., *Nucl. Phys.* A470 (1987) 445
- 1987BA13 J. Banaigs, J. Berger, P. Berthet, G. Bizard, M. Boivin, M. De Sanctis, J. Dufflo, F.L. Fabbri, R. Frascaria, L. Goldzahl et al., *Phys. Rev.* C35 (1987) 1416
- 1987BEYI A.V. Belozyorov, C. Borcea, Z. Dlouhy, A.M. Kalinin, N.H. Chau and Yu.E. Penionzhkevich, *JINR-E15-87-733* (1987)
- 1987BO39 O.V. Bochkarev, A.A. Korshennikov, E.A. Kuzmin, I.G. Mukha, A.A. Ogloblin, L.V. Chulkov and G.B. Yankov, *Yad. Fiz.* 46 (1987) 12; *Sov. J. Nucl. Phys.* 46 (1987) 7
- 1987BO40 C. Borcea, A.V. Belozyorov, Z. Dlouhy, A.M. Kalinin, N.H. Chau and Yu.E. Penionzhkevich, *Rev. Roum. Phys.* 32 (1987) 497
- 1987BR02 R.E. Brown, F.D. Correll, P.M. Hegland, J.A. Koepke and C.H. Poppe, *Phys. Rev.* C35 (1987) 383
- 1987BR07 M. Bruno, F. Cannata, M. D'Agostino, M.L. Fiandri, M. Frisoni, H. Oswald, P. Niessen, J. Schulte-Uebbing, H. Paetz gen. Schieck, P. Doleschall et al., *Phys. Rev.* C35 (1987) 1563
- 1987BU27 N.T. Burtebaev, A.D. Duisebaev, V.S. Sadkovskii and G.A. Feofilov, *Izv. Akad. Nauk SSSR Ser. Fiz.* 51 (1987) 615; *Bull. Acad. Sci. USSR Phys. Ser.* 51 (1987) 191
- 1987CA30 G. Cardella, A. Cunsolo, A. Foti, G. Imme, G. Pappalardo, G. Raciti, F. Rizzo, N. Alamanos, B. Berthier and N. Saunier, *Phys. Rev.* C36 (1987) 2403
- 1987CH08 Z. Chen, C.K. Gelbke, J. Pochodzalla, C.B. Chitwood, D.J. Fields, W.G. Lynch and M.B. Tsang, *Phys. Lett.* B186 (1987) 280
- 1987CH33 Z. Chen, C.K. Gelbke, W.G. Gong, Y.D. Kim, W.G. Lynch, M.R. Maier, J. Pochodzalla, M.B. Tsang, F. Saint-Laurent, D. Ardouin et al., *Phys. Rev.* C36 (1987) 2297
- 1987DA31 B.V. Danilin, M.V. Zhukov, A.A. Korshennikov, L.V. Chulkov and V.D. Efros, *Yad. Fiz.* 46 (1987) 427; *Sov. J. Nucl. Phys.* 46 (1987) 225
- 1987DE02 A.C. Demijanov, V.N. Bragin, A.A. Ogloblin, A.L. Lebedev, J.M. Bang, S.A. Goncharov, S.N. Ershov, F.A. Gareev and P.P. Korovin, *Phys. Lett.* B184 (1987) 129
- 1987EY01 W. Eyrich, A. Hofmann, A. Lehmann, B. Muhldorfer, H. Schlosser, H. Wirth, H.J. Gils, H. Rebel and S. Zagromski, *Phys. Rev.* C36 (1987) 416

- 1987FO08 D. Fox, D.A. Cebra, J. Karn, C. Parks, G.D. Westfall and W.K. Wilson, Phys. Rev. C36 (1987) 640
- 1987GA20 A.K. Ganguly, B. Chaudhuri and B.B. Baliga, Nuovo Cim. A97 (1987) 639
- 1987GL01 I.V. Glavanakov, A.L. Deynezhenko, V.N. Eponeshnikov, Yu.F. Krechetov, G.A. Pleshkov, G.M. Radutsky, G.A. Saruev, A.A. Sidorov, V.A. Tryasuchev and E.N. Shuvalov, Yad. Fiz. 45 (1987) 3; Sov. J. Nucl. Phys. 45 (1987) 1; Erratum Sov. J. Nucl. Phys. 46 (1987) 384
- 1987GLZW Yu.A. Glukhov, S.B. Sakuta and D.N. Stepanov, in Yurmala (1987) 383
- 1987GO12 M.S. Golovkov and V.Z. Goldberg, Izv. Akad. Nauk SSSR, Ser. Fiz. 51 (1987) 129; Bull. Acad. Sci. USSR, Phys. Ser. 51 (1987) 120
- 1987GO1S Goryunov et al., in Yurmala (1987) 474
- 1987GO27 S.A. Goncharov, A.M. Mukhamedzhanov, E.A. Romanovsky, G.E. Valiev, I.R. Gulamov, T. Iskhakov, G. Nie, N.K. Tomopheyuk, R. Yarmukhamedov, V. Kroha et al., Czech. J. Phys. B37 (1987) 168
- 1987GR08 W. Gruebler, Nucl. Phys. A463 (1987) 193c.
- 1987GUZZ I.R. Gulamov, T. Iskhakov, A.M. Mukhamedzhanov, Sh. Kayumov, A.A. Karakhodzhaev, G.K. Ni, E.A. Romanovsky and G.S. Valiev, in Yurmala (1987) 344
- 1987HE22 R. Helmer, Can. J. Phys. 65 (1987) 588
- 1987HU02 J.R. Hurd, J.S. Boswell, R.C. Minehart, L.B. Rees, Y. Tzeng, H.J. Ziock and K.O.H. Ziock, Nucl. Phys. A462 (1987) 605
- 1987HU13 J.R. Hurd, J.S. Boswell, R.C. Minehart, Y. Tzeng, H.J. Ziock, K.O.H. Ziock, L.C. Liu and E.R. Siciliano, Nucl. Phys. A475 (1987) 743
- 1987KO1X V.V. Komarov, A.M. Green, A.M. Popova and V.L. Shablov, Mod. Phys. Lett. A2 (1987) 81
- 1987KR07 A.T. Kruppa, R. Beck and F. Dickmann, Phys. Rev. C36 (1987) 327
- 1987KR09 A. Krauss, H.W. Becker, H.P. Trautvetter and C. Rolfs, Nucl. Phys. A467 (1987) 273
- 1987LA1J A. Lamberty, E. Michels and P. De Bievre, Int. J. Mass Spectrom. Ion Proc. 79 (1987) 311
- 1987LA25 M. Lattuada, F. Riggi, D. Vinciguerra, C. Spitaleri and D. Miljanic, Z. Phys. A328 (1987) 497
- 1987LE1N D.R. Lehman, AIP Conf. Proc. 162 (1987) 131
- 1987MO1I A. Mondragon and E. Hernandez, in Leuven (1988) 794
- 1987NA1I Naumenko et al., in Yurmala (1987) 370
- 1987NI04 W. Nitsche, G.J. Wagner, K.T. Knopfle, P. Grabmayr and Y. Kawazoe, Z. Phys. A326 (1987) 435

- 1987PA12 S.J. Padalino, K. Sartor, L.C. Dennis and K.W. Kemper, Phys. Rev. C35 (1987) 1692
- 1987PI06 I.M. Piskarev, Yad. Fiz. 45 (1987) 1222; Sov. J. Nucl. Phys. 45 (1987) 758
- 1987PO03 J. Pochodzalla, C.K. Gelbke, W.G. Lynch, M. Maier, D. Ardouin, H. Delagrange, H. Doubre, C. Gregoire, A. Kyanowski, W. Mittig et al., Phys. Rev. C35 (1987) 1695
- 1987PO18 D. Pocanic, K. Wang, C.J. Martoff, S.S. Hanna, R.C. Byrd, C.C. Foster, D.L. Friesel and J. Rapaport, Can. J. Phys. 65 (1987) 687
- 1987SA21 Y. Sakuragi, Phys. Rev. C35 (1987) 2161
- 1987TA07 Y. Tagishi, Y. Aoki, M. Kurokawa, T. Murayama, T. Sakai, M. Takei, M. Tomizawa and K. Yagi, Phys. Rev. C35 (1987) 1153
- 1987TA13 T.N. Taddeucci, C.A. Goulding, T.A. Carey, R.C. Byrd, C.D. Goodman, C. Gaarde, J. Larsen, D. Horen, J. Rapaport and E. Sugarbaker, Nucl. Phys. A469 (1993) 125
- 1987TA21 M. Tanaka, T. Yamagata, S. Nakayama, M. Inoue, Y. Sakuragi, M. Kamimura, K. Goto, K. Katori, M. Yanagi and H. Ogata, Phys. Rev. C36 (1987) 2146
- 1987TO06 M. Tosaki, M. Fujiwara, K. Hosono, T. Noro, H. Ito, T. Yamazaki and H. Ikegami, Nucl. Phys. A463 (1987) 429c.
- 1987VA05 V.V. Varlamov, B.S. Ishkhanov, V.V. Surgutanov, A.P. Chernyaev and R.A. Er-amzhyan, Izv. Akad. Nauk SSSR Ser. Fiz. 51 (1987) 195; Bull. Acad. Sci. USSR Phys. Ser. 51 (1987) 179
- 1987VA08 G. van der Steenhoven, A.M. van den Berg, H.P. Blok, S. Boffi, J.F.J. van den Brand, R. Ent, T. de Forest, Jr., C. Giusti, J.W.A. den Herder, E. Jans et al., Phys. Rev. Lett. 58 (1987) 1727
- 1987VA1N Van Der Steenhoven et al., in Panic (1987) 618
- 1987VA31 S.P. Van Verst, D.P. Sanderson, K.W. Kemper, D. Shapira, R.L. Varner and B. Shivakumar, Phys. Rev. C36 (1987) 1865
- 1987VAZY S.P. van Verst, D.P. Sanderson, K.W. Kemper, D.E. Trcka, G.A. Hall, V. Hnizdo, K.R. Chapman and B.G. Schmidt, Bull. Amer. Phys. Soc. 32 (1987) 1547, AE10
- 1987VD1A A.I. Vdovin, A.V. Golovin and I.I. Loschakov, Sov. J. Part. Nucl. 18 (1987) 573
- 1987VU1A B. Vuaridel, W. Gruebler, V. Konig, P.A. Schmelzbach, K. Elsener, J. Ulbricht, D. Singy, Ch. Forstner, M. Bittcher, M. Bruno et al., Helv. Phys. Acta. 60 (1987) 326
- 1987VU1B B. Vuaridel, W. Gruebler, V. Konig, P.A. Schmelzbach, M. Bittcher, K. Elsener, Ch. Forstner, M. Bruno, F. Cannata, M. D'Agostino et al., Few-Body Syst. Suppl. 2 (1987) 504
- 1987ZA07 M. Zadro, D. Miljanic, M. Lattuada, F. Riggi and C. Spitaleri, Nucl. Phys. A474 (1987) 373
- 1988ABZW S.N. Abramovich, B.Ya. Guzhovsky and V.N. Protopopov, Program and Theses, Proc. 38th Ann. Conf. Nucl. Spectrosc. Struct. At. Nuclei, Baku, 1988, p. 299

- 1988AJ01 F. Ajzenberg-Selove, Nucl. Phys. A490 (1988) 1
- 1988AL1J I.M. Al-Khamiesi, B.K. Kerimov and M.Ya. Safin, Acta Phys. Pol. B19 (1988) 213
- 1988AR20 N. Arena, S. Cavallaro, G. Fazio, G. Giardina, A. Italiano and F. Mezzanares, J. Phys. Soc. Jpn. 57 (1988) 3773
- 1988BE1I Bekbaev et al., in Baku (1988) 442
- 1988BE2B S.L. Belostotsky, Yu.V. Dotsenko, N.P. Kuropatkin, O.V. Mikluho, V.N. Nikulin, O.E. Prokofiev, Yu.A. Scheglov, V.E. Starodubsky, A.Yu. Tsaregorodtsev, A.A. Vorobyov and M.B. Zhalov, in Novosibirsk (1988) 191
- 1988BE58 S.V. Berezovsky and A.P. Soznik, Ukr. Fiz. Zh. 33 (1988) 993
- 1988BEYJ A.V. Belozerov, K. Borchia, I. Vintsour, Z. Dlougy, N.K. Tyau and Yu.Eh. Penionzhkevich, in Baku (1988) 380.
- 1988BO18 O.V. Bochkarev, A.A. Korshennikov, E.A. Kuzmin, I.G. Mukha, L.V. Chulkov and G.B. Yankov, Yad. Fiz. 47 (1988) 616; Sov. J. Nucl. Phys. 47 (1988) 391
- 1988BO1J Bochkarev et al., in Baku (1988) 347
- 1988BO1Y F. Bonignore, P. D'Agostino, G. Fazio, G. Giardina, S. Interdonato, A. Italiano, R. Palamara and A. Taccone, Report INFN/BE-88/5
- 1988BO37 C. Boni, E. Cereda, G.M. Braga Marcazzan and V. De Tomasi, Nucl. Instrum. Meth. Phys. Res. B35 (1988) 80
- 1988BO38 O.V. Bochkarev, A.A. Korshennikov, E.A. Kuzmin, I.G. Mukha, L.V. Chulkov and G.B. Yankov, Pisma Zh. Eksp. Teor. Fiz. 48 (1988) 124; JETP Lett. 48 (1988) 133
- 1988BR18 M. Bruno, F. Cannata, M. D'Agostino, M.L. Fiandri, M. Herman, H.M. Hofmann, B. Vuaridel, V. Konig, W. Gruebler, P.A. Schmelzbach et al., Phys. Rev. C38 (1988) 521
- 1988BU1Q Buranov et al., in Baku (1988) 363
- 1988BU25 A.Yu. Buki, N.G. Shevchenko, V.N. Polishchuk, A.A. Khomich and B.V. Mazanko, Yad. Fiz. 48 (1988) 913
- 1988BUZH V.V. Buranov, N.I. Venikov, Yu.A. Glukhov, A.M. Dobyichin, A.A. Ogloblin, S.B. Sakuta and V.N. Unezhev, in Baku (1988) 362
- 1988CA11 P.J. Carlos, Ph. Bourgeois, J. Fagot, J.L. Fallou, P. Garganne, J.M. Laget, A. Lepretre, A. de Miniac, A. Veyssiere, J. Jury et al., Phys. Lett. B203 (1988) 33
- 1988CA1J C. Carraro, A. Schafer and S.E. Koonin, Astrophys. J. 331 (1988) 565
- 1988CA26 G.R. Caughlan and W.A. Fowler, At. Data Nucl. Data Tables 40 (1988) 283
- 1988DI02 S.S. Dietrich and B.L. Berman, At. Data Nucl. Data Tables 38 (1988) 199
- 1988DU04 E.I. Dubovoy and G.I. Chitanava, Yad. Fiz. 47 (1988) 75; Sov. J. Nucl. Phys. 47 (1988) 48.

- 1988EL01 K. Elsener, W. Gruebler, F. Sperisen, K. Ghazi-Wakili, V. Konig, P.A. Schmelzbach, B. Vuaridel, M. Bittcher, D. Singy and J. Ulbricht, Nucl. Phys. A481 (1988) 227
- 1988ER06 R.A. Eramzhyan, M. Gmitro, T.D. Kaipov, S.S. Kamalov and R. Mach, J. Phys. (London) G14 (1988) 1511
- 1988ES01 A. Eskandarian, D.R. Lehman and W.C. Parke, Phys. Rev. C38 (1988) 2341; Erratum Phys. Rev. C39 (1989) 1188
- 1988FE06 D. Ferenc, B. Antolkovic and G. Paic, Fizika 20 (1988) 77
- 1988FU09 Y. Fujiwara, Q.K.K. Liu and Y.C. Tang, Phys. Rev. C38 (1988) 1531
- 1988GA14 N.O. Gaiser, S.E. Darden, R.C. Luhn, H. Paetz gen. Schieck and S. Sen, Phys. Rev. C38 (1988) 1119
- 1988GR32 K.A. Gridnev, V.B. Subbotin and S.N. Fadeev, Izv. Akad. Nauk SSSR Ser. Fiz. 52 (1988) 2262; Bull. Acad. Sci. USSR Phys. Ser. 52 (1988) 184
- 1988GUZW I.R. Gulamov, A.M. Mukhamedzhanov and G.K. Ni, in Baku (1988) 300
- 1988HA12 S.S. Hanna, J. Phys. (London) G14 (1988) S283
- 1988HA25 L.F. Hansen, J. Rapaport, X. Wang, F.A. Barrios, F. Petrovich, A.W. Carpenter and M.J. Threapleton, Phys. Rev. C38 (1988) 525
- 1988HA2C S.S. Hanna, in Novosibirsk (1988) 418
- 1988HE16 J. Hesselbarth, S. Khan, Th. Kihm and K.T. Knopfle, Z. Phys. A33 (1988) 365
- 1988JA01 K.P. Jackson, A. Celler, W.P. Alford, K. Raywood, R. Abegg, R.E. Azuma, C.K. Campbell, S. El-Kateb, D. Frekers, P.W. Green et al., Phys. Lett. B201 (1988) 25
- 1988KA09 K. Katori, T. Shimoda, T. Fukuda, S. Shimoura, A. Sakaguchi, M. Tanaka, T. Yamagata, N. Takahashi, H. Ogata, M. Kamimura et al., Nucl. Phys. A480 (1988) 323
- 1988KA25 H. Kanada, T. Kaneko and Y.C. Tang, Phys. Rev. C38 (1988) 2013
- 1988KA38 V.I. Karmanov, V.V. Komarov, A.M. Popova, N.A. Sotnikova and V.L. Shablov, Izv. Akad. Nauk SSSR Ser. Fiz. 52 (1988) 936; Bull. Acad. Sci. USSR Phys. Ser. 52 (1988) 99
- 1988KA41 V.L. Kashevarov and G.A. Sokol, Fiz. Elem. Chastits At. Yad. 19 (1988) 1299; Sov. J. Part. Nucl. 19 (1988) 560
- 1988KA46 V.G. Kadmsky, S.G. Kadmsky, P.A. Lukyanovich and A.T. Rudchik, Ukr. Fiz. Zh. 33 (1988) 1309
- 1988KH08 D.T. Khoa, Nucl. Phys. A484 (1988) 376
- 1988KO1C Kozchy, Mashkarov and Rudchik, in Baku (1988) 350
- 1988KO32 Yu.E. Kozyr and M.V. Sokolov, Izv. Akad. Nauk SSSR, Ser. Fiz. 52 (1988) 902; Bull. Acad. Sci. USSR, Phys. Ser. 52 (1988) 65
- 1988LA11 M. Lattuada, F. Riggi, D. Vinciguerra, C. Spitaleri, G. Vourvopoulos, D. Miljanic and E. Norbeck, Z. Phys. A330 (1988) 183

- 1988LA1C A. Lamberty and P. de Bievre, *Int. J. Mass Spectrom. Ion Proc.* 83 (1988) 135
- 1988LO1E R.W. Lourie, *AIP Conf. Proc.* 176 (1988) 103
- 1988MA1V V.E. Markushin, *Muon Catal. Fusion* 3 (1988) 395
- 1988MIZX J. Mildenberger, O. Hausser, R. Abegg, W.P. Alford, A. Celler, D. Frekers, R. Helmer, R. Henderson, K. Hicks, K.P. Jackson, R. Jeppesen et al., *Bull. Amer. Phys. Soc.* 33 (1988) 1180, AG5
- 1988MO1I A. Mondragón and E. Hernández, in *Belgium* (1988) 794
- 1988NA02 A. Nadasen, M. McMaster, G. Gunderson, A. Judd, S. Villanueva, P. Schwandt, J.S. Winfield, J. van der Plicht, R.E. Warner, F.D. Becchetti et al., *Phys. Rev.* C37 (1988) 132
- 1988NA06 R. Nagaoka and K. Ohta, *Ann. Phys.* 184 (1988) 148
- 1988NAZX A. Nadasen, A. McMaster, J. Tavormina, F.D. Becchetti, J.W. Janecke, P. Schwandt, J. Winfield and R.E. Warner, *Bull. Amer. Phys. Soc.* 33 (1988) 1101, KJ13
- 1988PA26 M.V. Pasechnik, V.B. Shostak, V.P. Badovsky, G.P. Palkin, S.B. Kumshaev and V.P. Likhachev, *Izv. Akad. Nauk SSSR Ser. Fiz.* 52 (1988) 928; *Bull. Acad. Sci. USSR Phys. Ser.* 52 (1988) 91
- 1988PA27 M.V. Pasechnik, V.B. Shostak, V.P. Badovsky, G.P. Palkin, P.G. Ofengenden, S.B. Kumshaev and V.P. Likhachev, *Ukr. Fiz. Zh.* 33 (1988) 976
- 1988PO1J C. Powell, J. Nering, B.C. Maglich and A. Wilmerding, *Nucl. Instrum. Meth. Phys. Res.* A271 (1988) 41
- 1988RA27 Md.A. Rahman, *Nuovo Cim.* A100 (1988) 419
- 1988SE07 V.M. Semjonov, K.M. Omar, K.A. Gridnev and E.F. Hefter, *Phys. Rev.* C38 (1988) 765
- 1988SU12 I. Supek, I. Slaus, Y. Koike, P.A. Treado and J.M. Lambert, *Few-Body Syst.* 4 (1988) 39
- 1988TA08 M. Tanaka, T. Yamagata, S. Nakayama, M. Inoue, K. Goto, K. Katori, M. Yanagi and H. Ogata, *Nucl. Instrum. Meth. Phys. Res.* A267 (1988) 139
- 1988TRZY D.E. Trcka, S.P. Van Verst, A.D. Frawley, K.W. Kemper, J.D. Fox, V. Hnizdo and E.G. Myers, *Bull. Amer. Phys. Soc.* 33 (1988) 1101, KJ12.
- 1988VAZY S.P. Van Verst, K.W. Kemper, D.E. Trcka, G.A. Hall, V. Hnizdo, K.R. Chapman and B.G. Schmidt, *Bull. Amer. Phys. Soc.* 33 (1988) 1101, KJ11.
- 1988VU01 B. Vuaridel, W. Gruebler, V. Konig, K. Elsener, P.A. Schmelzbach, J. Ulbricht, Ch. Forstner, M. Bittcher, D. Singy, M. Bruno et al., *Nucl. Phys.* A484 (1988) 34
- 1988WA24 K. Wang, C.J. Martoff, D. Pocanic, W.J. Cummings, S.S. Hanna, R.C. Byrd and C.C. Foster, *Phys. Rev.* C38 (1988) 2478

- 1988WA29 R.E. Warner, A. Okihana, M. Fujiwara, N. Matsuoka, K. Tamura, M. Tosaki, T. Oh-sawa, K. Fukunaga, P.A. Kimoto and N. Koori, Phys. Rev. C38 (1988) 2945
- 1988WE20 H.R. Weller and D.R. Lehman, Ann. Rev. Nucl. Part. Sci. 38 (1988) 563
- 1988WO10 C.L. Woods, F.C. Barker, W.N. Catford, L.K. Fifield and N.A. Orr, Aust. J. Phys. 41 (1988) 525
- 1989AR02 T. A. Arakelyan, L. S. Davtyan and S. G. Matinyan, Yad. Fiz. 49 (1989) 86
- 1989AR08 N. Arena, Seb. Cavallaro, A. D'Arrigo, G. Fazio, G. Giardina, A. Italiano, M. Herman and M. Lombardi, Phys. Rev. C40 (1989) 1126
- 1989AR20 N. Arena, Seb. Cavallaro, P. D'Agostino, G. Fazio, G. Giardina, A. Italiano, F. Mezzanares, M. Herman and M. Lombardi, Nuovo Cim. A102 (1989) 1327
- 1989ARZR N. Arena, Seb. Cavallaro, A. D'Arrigo, G. Fazio, G. Giardina, A. Italiano, M. Herman, G. Reffo and A. Taccone, in Vancouver (1989) C25; TRI-89-2 (1989)
- 1989BA25 A.D. Bates, R.P. Rassool, E.A. Milne, M.N. Thompson and K.G. McNeill, Phys. Rev. C40 (1989) 506
- 1989BA2P J.N. Bahcall, Neutrino Astrophys. (Publ. Cambridge Univ. Press 1989)
- 1989BE08 Gy. Bencze, Nucl. Phys. A492 (1989) 459
- 1989BO1N Bochkarev et al., in Tashkent (1989) 334
- 1989BO25 O.V. Bochkarev, A.A. Korshennikov, E.A. Kuzmin, I.G. Mukha, L.V. Chulkov and G.B. Yankov, Yad. Fiz. 49 (1989) 1521
- 1989BO42 O. V. Bochkarev, L. V. Chulkov, A. A. Korshennikov, E. A. Kuzmin, I. G. Mukha and G. B. Yankov, Nucl. Phys. A505 (1989) 215
- 1989BR23 M. Bruno, F. Cannata, M. D'Agostino, M. L. Fiandri, M. Herman, H. M. Hofmann, B. Vuaridel, W. Gruebler, V. Konig, P. A. Schmelzbach et al., Nucl. Phys. A501 (1989) 462
- 1989BU10 N.A. Burkova, Yu.V. Vladimirov, V.B. Ganenko, V.A. Gushchin, I.G. Evseev, Yu.V. Zhebrovskij, M.A. Zhusupov, L.Ya. Kolesnikov, V.P. Likhachev, S.A. Pashchuk et al., Phys. Lett. B223 (1989) 136
- 1989CH2F L. Chatterjee, Indian J. Pure Applied Phys. 27 (1989) 787
- 1989CO22 M.E. Colin, C. Friedli and P. Lerch, Radiochim. Acta. 46 (1989) 13
- 1989CR01 R. Crespo, A. M. Eiro and F. D. Santos, Phys. Rev. C39 (1989) 305
- 1989DE1A A. De, S. Karmakar, T. Roychaudhury, S.S. Dasgupta, S.N. Chintalapudi, M. Ismail, S.R. Banerjee and A.S. Divatia, Indian J. Phys. B63 (1989) 94
- 1989DE34 A.S. Demyanova, J.M. Bang, F.A. Gareev, S.A. Goncharov, S.N. Ershov, A.A. Ogloblin and P.P. Korovin, Nucl. Phys. A501 (1989) 336
- 1989DO1B B. Doyle, B. Goulard and N.C. Mukhopadhyay, in Wein 89 (1989) 673

- 1989ER07 R.A. Eramzhyan, G.G. Ryzhikh, V.I. Kukulín and Yu.M. Tchuvil'sky, *Phys. Lett.* B228 (1989) 1
- 1989ES05 A. Eskandarian, D.R. Lehman and W.C. Parke, *Phys. Rev.* C39 (1989) 1685
- 1989ET05 E. Etim and L. Satta, *Nuovo Cim.* A101 (1989) 775
- 1989FA1B Falk et al., in Sao Paulo (1989) 297
- 1989FI1E G.F. Filippov, *Riv. Nuovo Cim.* 12 (1989) 1
- 1989GL07 I.V. Glavanakov, A.L. Deinezhenko, V.N. Eponeshnikov, P.P. Krasnonosenkikh, Yu.F. Krechetov, N.A. Lashuk, G.A. Pleshkov and E.N. Shuvalov, *Yad. Fiz.* 50 (1989) 1516
- 1989GL1D Glovatska et al., Tashkent (1989) 339
- 1989GO07 O.Yu. Goryunov, S.G. Kadmsky, E.I. Koshchy, P.A. Lukyanovich, Yu.G. Mashkarov, O.F. Nemets and A.T. Rudchik, *Yad. Fiz.* 49 (1989) 421
- 1989GO18 A.M. Gorbatov, P.V. Komarov, Yu.N. Krylov, A.V. Bursak, V.L. Skopich, P.Yu. Nikishov and E.A. Kolganova, *Yad. Fiz.* 50 (1989) 347; *Sov. J. Nucl. Phys.* 50 (1989) 218
- 1989GO26 O. Yu. Goryunov, I. I. Zalyubovsky, E. I. Koshchy, S. B. Kumshaev, Yu. G. Mashkarov, O. F. Nemets, A. T. Rudchik, V. K. Chernievsky, O. A. Ponkratenk and A. V. Shustov, *Ukr. Fiz. Zh.* 34 (1989) 1144
- 1989GR02 M. Grote, C. Hammerich, H. Klindt and U. Strohbush, *Nucl. Phys.* A491 (1989) 173
- 1989GR06 P.A.M. Gram, S.A. Wood, E.R. Kinney, S. Hoibraten, P. Mansky, J.L. Matthews, T. Soos, G.A. Rebka, Jr. and D.A. Roberts, *Phys. Rev. Lett.* 62 (1989) 1837
- 1989GU05 G.S. Gurevich, V.M. Lebedev, O.F. Nemets, Yu.N. Pavlenko, V.M. Pugach, A.V. Spassky and I.B. Teplov, *Yad. Fiz.* 49 (1989) 3
- 1989HA17 M. Haller, M. Betz, W. Kretschmer, A. Rauscher, R. Schmitt and W. Schuster, *Nucl. Phys.* A496 (1989) 189
- 1989HA18 M. Haller, W. Kretschmer, A. Rauscher, R. Schmitt and W. Schuster, *Nucl. Phys.* A496 (1989) 205
- 1989HAZV L.F. Hansen, F.S. Dietrich and R.L. Walter, *Bull. Amer. Phys. Soc.* 34 (1989) 1809
- 1989HE17 N. Heide, D. K. Srivastava and H. Rebel, *Phys. Rev. Lett.* 63 (1989) 601
- 1989HE28 N. Heide, H. Rebel, V. Corcalciuc, H. J. Gils, H. Jelitto, J. Kiener, J. Wentz, S. Zagromski and D. K. Srivastava, *Nucl. Phys.* A504 (1989) 374
- 1989HN1A Hnizdo et al., Sao Paulo (1989) 327
- 1989IS1B B.S. Ishkhanov, I.M. Kapitonov, V.G. Neudachin, V.G. Shevchenko, R.A. Eramzhyan and N.P. Yudin, *Vestn. Mosk. U. Fiz. Astron. SSSR* 30 (1989) 3
- 1989JE01 H. Jelitto, J. Buschmann, V. Corcalciuc, H.J. Gils, N. Heide, J. Kiener, H. Rebel, C. Samanta and S. Zagromski, *Z. Phys.* A332 (1989) 317

- 1989JI1A L. Jin, W.D. Arnett and S.K. Chakrabarti, *Astrophys. J.* 336 (1989) 572
- 1989KA30 S. Karataglidis, D. Zubanov, P.D. Harty and M.N. Thompson, *Nucl. Phys.* A501 (1989) 108
- 1989KR08 V. M. Krasnopolsky, V. I. Kukulin and J. Horacek, *Czech. J. Phys.* B39 (1989) 593
- 1989KU21 V.I. Kukulin, G.G. Ryzhikh, Yu.M. Chuvilsky and R.A. Eramzhyan, *Izv. Akad. Nauk SSSR Ser. Fiz.* 53 (1989) 121; *Bull. Acad. Sci. USSR Phys. Ser.* 53 (1989) 118
- 1989LA13 J.B.J.M. Lanen, A.M. van den Berg, H.P. Blok, J.F.J. van den Brand, C.T. Christou, R. Ent, A.G.M. van Hees, E. Jans, G.J. Kramer, L. Lapikas et al., *Phys. Rev. Lett.* 62 (1989) 2925
- 1989LA22 J.B.J.M. Lanen, R.G. Lovas, A.T. Kruppa, H.P. Blok, J.F.J. van den Brand, R. Ent, E. Jans, G.J. Kramer, L. Lapikas, E.N.M. Quint, G. van der Steenhoven et al., *Phys. Rev. Lett.* 63 (1989) 2793
- 1989LE07 M. LeMere and Y.C. Tang, *Phys. Rev.* C39 (1989) 1696
- 1989LI09 J. Lichtenstadt, J. Alster, M.A. Moinester, J. Dubach, R.S. Hicks, G.A. Peterson and S. Kowalski, *Phys. Lett.* B219 (1989) 394
- 1989LIZO B.J. Lieb, H.O. Funsten, J. Mackenzie, C.F. Perdrisat, V. Punjabi, C. Lyndon, E. Cheung, P. Ulmer, R. Estep, L.C. Liu et al., *Bull. Amer. Phys. Soc.* 34 (1989) 1828
- 1989NA02 A. Nadasen, M. McMaster, M. Fingal, J. Tavormina, P. Schwandt, J. S. Winfield, M. F. Mohar, F. D. Becchetti, J. W. Janecke and R. E. Warner, *Phys. Rev.* C39 (1989) 536
- 1989NA11 A. Nadasen, M. McMaster, M. Fingal, J. Tavormina, J. S. Winfield, R. M. Ronningen, P. Schwandt, F. D. Becchetti, J. W. Janecke and R. E. Warner, *Phys. Rev.* C40 (1989) 1237
- 1989NA23 G.A. Naumenko, E.V. Repenko, V.N. Stibunov and V.A. Tryasuchev, *Pisma Zh. Eksp. Teor. Fiz.* 50 (1989) 226; *JETP Lett.* 50 (1989) 251
- 1989RA17 P. Raghavan, *At. Data Nucl. Data Tables* 42 (1989) 189.
- 1989RA1G J. Rapaport, *Santa Fe* 88 (1989) 186
- 1989RE1G H. Rebel, *Calcutta* (1989) 364
- 1989ROZY D. Rothenberger, B. G. Ritchie, J. R. Comfort, R. A. Giannelli, J. R. Tinsley, N. S. Chant, D. J. Mack, P. G. Roos, J. D. Silk, G. S. Kyle et al., *Bull. Amer. Phys. Soc.* 34 (1989) 1204
- 1989RU05 K. Rusek, J. Giroux, H. J. Jansch, H. Vogt, K. Becker, K. Blatt, A. Gerlach, W. Korsch, H. Leucker, W. Luck et al., *Nucl. Phys.* A503 (1989) 223
- 1989SA20 N.V. Samsonenko, C.L. Kathat, M.A. Ousmane and A. L. Samgin, *J. Phys.* G15 (1989) 1413
- 1989SC25 A. Scalia, *Nuovo Cim.* A102 (1989) 953

- 1989SHZS S. Shirato, S. Shibuya, K. Hata, Y. Ando and K. Shibata, JAERI-M 89-107 (Jpn. Atomic Energy Res.) (1989)
- 1989SI02 P.J. Simmonds, N.M. Clarke, K.I. Pearce, R.J. Griffiths, B. Stanley, S. Roman, A. Farooq, G. Rai, M.C. Mannion and C.A. Ogilvie, J. Phys. (London) G15 (1989) 353
- 1989TA21 R. Tacik, E.T. Boschitz, R. Meier, S. Ritt, M. Wessler, K. Junker, J.A. Konter, S. Mango, D. Renker, B. van den Brandt et al., Phys. Rev. Lett. 63 (1989) 1784
- 1989TE04 H. Terazawa, J. Phys. Soc. Jpn. 58 (1989) 767
- 1989TO04 M. Tosaki, M. Fujiwara, K. Hosono, T. Noro, H. Ito, T. Yamazaki and H. Ikegami, Nucl. Phys. A493 (1989) 1
- 1989TR09 V.A. Tryasuchev, Yad. Fiz. 49 (1989) 1056
- 1989VA04 S. P. Van Verst, D. P. Sanderson, D. E. Trcka, K. W. Kemper, V. Hnizdo, B. G. Schmidt and K. R. Chapman, Phys. Rev. C39 (1989) 853
- 1989VA20 V. S. Vasilevsky and I. Yu. Rybkin, Yad. Fiz. 50 (1989) 662; Sov. J. Nucl. Phys. 50 (1989) 411
- 1989WA1F J. W. Watson, Nucl. Instrum. Meth. Phys. Res. B40/41 (1989) 481
- 1989WA26 R. E. Warner, A. Okihana, M. Fujiwara, N. Matsuoka, K. Tamura, M. Tosaki, T. Ohsawa, K. Fukunaga, S. Kakigi, J. Kasagi et al., Nucl. Phys. A503 (1989) 161
- 1989YO03 H. Yokota, S. Igarashi, K. Hama, T. Mori, T. Katsumi, K. Nakayama, K. Ichimaru, R. Chiba, K. Nakai and J. Chiba, Phys. Rev. C39 (1989) 2090
- 1989YO05 H. Yokota, S. Igarashi, K. Hama, T. Mori, T. Katsumi, K. Ichimaru, K. Nakayama, R. Chiba, K. Nakai and J. Chiba, Phys. Rev. C40 (1989) 270
- 1989YO07 H. Yokota, S. Igarashi, K. Hama, T. Mori, T. Katsumi, K. Ichimaru, K. Nakayama, R. Chiba, K. Nakai and J. Chiba, Phys. Rev. C40 (1989) 1069.
- 1989ZHZZ D. Zhang, H. Breuer, N.S. Chant, B.S. Flanders, S.D. Hyman, D.J. Mack, P.G. Roos, J.D. Silk, K. Dhuga, G.S. Kyle et al., Bull. Amer. Phys. Soc. 34 (1989) 1205
- 1990AJ01 F. Ajzenberg-Selove, Nucl. Phys. A506 (1990) 1.
- 1990AL40 D.V. Aleksandrov, E.Yu. Nikol'skii and D.N. Stepanov, Yad. Fiz. 52 (1990) 933; Sov. J. Nucl. Phys. 52 (1990) 593
- 1990AM04 A.I. Amelin, M.G. Gornov, Yu.B. Gurov, A.I. Ilin, V.P. Koptev, P.V. Morokhov, K.O. Oganessian, V.A. Pechkurov, V.I. Savelev, F.M. Sergeev et al., Pisma Zh. Eksp. Teor. Fiz. 51 (1990) 607; JETP Lett. (USSR) 51 (1990) 688
- 1990BE49 C. Bennhold, L. Tiator and L.E. Wright, Can. J. Phys. 68 (1990) 1270
- 1990BE54 S.M. Bekbaev, G. Kim and R. A. Eramzhyan, Izv. Akad. Nauk SSSR, Ser. Fiz. 54 (1990) 1014; Bull. Acad. Sci. USSR, Phys. Ser. 52, No.5 (1990) 198
- 1990BL13 L.D. Blokhintsev, V.I. Kukulkin and D.A. Savin, Yad. Fiz. 51 (1990) 1289; Sov. J. Nucl. Phys. 51 (1990) 819

- 1990BLZW C. Blyth, J.B.A. England, G.M. Field, O. Karban, C.N. Pinder, N.M. Clarke, G. Rai, R. Vlastou, L. Zybert and G.C. Morrison, *Bull. Amer. Phys. Soc.* 35 (1990) 1668
- 1990BR09 M. Bruno, F. Cannata, M. D'Agostino, M.L. Fiandri, M. Herman and H.M. Hofmann, *Phys. Rev. C* 41 (1990) 2435
- 1990BU29 N.A. Burkova, K.A. Zhaksibekova, M.A. Zhusupov and R.A. Eramzhyan, *Phys. Lett.* B248 (1990) 15
- 1990CR04 R. Crespo, A.M. Eiro and J.A. Tostevin, *Phys. Rev. C* 42 (1990) 1646
- 1990DA1H Dasgupta and Mandal, *Panic XII* (1990) Paper II-41
- 1990DA23 T.K. Dao and O.M. Knyazkov, *Fiz. Elem. Chastits At. Yad.* 21 (1990) 1456; *Sov. J. Part. Nucl.* 21 (1990) 623
- 1990DAZR B.V. Danilin and N.B. Shulgina, in *Leningrad 90* (1990) 227
- 1990DE16 P.K.A. de Witt Huberts, *J. Phys. (London)* G16 (1990) 507
- 1990DE1V P.K.A. de Witt Huberts, *Prog. Part. Nucl. Phys.* 24 (1990) 205
- 1990DO04 B. Doyle, B. Goulard and N.C. Mukhopadhyaya, *Phys. Rev. C* 42 (1990) 1361
- 1990EI01 A.M. Eiro and F.D. Santos, *J. Phys. (London)* G16 (1990) 1139
- 1990FU1H C. Funck and K. Langanke, *Int. J. Mod. Phys. A* 5 (1990) 195
- 1990GH1E Ghio et al., in *Panic XII* (1990) Paper I-77
- 1990GL04 C.W. Glover, C.C. Foster, P. Schwandt, J.R. Comfort, J. Rapaport, T.N. Taddeucci, D. Wang, G.J. Wagner, J. Seubert, A.W. Carpenter et al., *Phys. Rev. C* 41 (1990) 2487
- 1990GO14 O.Yu. Goryunov, E.I. Koshchii, Yu.G. Mashkarov, A.T. Rudchik, V.K. Chernievskii and Yu.M. Chuvil'skii, *Sov. J. Nucl. Phys.* 51 (1990) 595
- 1990GO26 M. Goswami, F. Ahmed and L.S. Kothari, *Ann. Nucl. Energy* 17 (1990) 549
- 1990GU23 B. Guo, X. Li and K. Chen, *Chin. J. Nucl. Phys.* 12 (1990) 215
- 1990HA29 P.G. Hansen, *Phys. Scr.* T32 (1990) 21
- 1990HA46 D. Harley, B. Muller and J. Rafelski, *J. Phys.* G16 (1990) 281
- 1990HE20 E. Hernandez and A. Mondragon, *J. Phys.* G16 (1990) 1339
- 1990HO1R H. Horiuchi, in *Santa Fe 90* (1990); *Nucl. Phys. A* 522 (1991) 257c.
- 1990HU09 J. Hufner and V. Kitipova, *Nucl. Phys. A* 517 (1990) 571
- 1990JO1D Jodice et al., *Panic XII* (1990) Paper I-76
- 1990KA14 S. Kailas, *Phys. Rev. C* 41 (1990) 2943
- 1990KAZH S. Kato, N. Matsuoka, K. Hosono, T. Noro, M. Yosoi and K. Shrane, *Osaka Univ. Lab. Nucl. Studies Ann. Rept.* 1989 (1990) 39
- 1990KR12 R. Krivec and M.V. Mihailovic, *Few-Body Syst.* 8 (1990) 45
- 1990KRZX L.H. Kramer and H.R. Weller, *Bull. Amer. Phys. Soc.* 35 (1990) 1058

- 1990KU06 V.I. Kukulín and V.N. Pomerantsev, *Yad. Fiz.* 51 (1990) 376; *Sov. J. Nucl. Phys.* 51 (1990) 240
- 1990KU12 V.I. Kukulín, V.T. Voronchev, T.D. Kaipov and R.A. Eramzhyan, *Nucl. Phys.* A517 (1990) 221
- 1990KU16 V.I. Kukulín, V.M. Krasnopolsky, E.V. Kuznetsova and J. Horacek, *Czech. J. Phys.* B40 (1990) 945
- 1990KU23 A.V. Kuznichenko, A.S. Molev and G.M. Onishchenko, *Izv. Akad. Nauk SSSR, Ser. Fiz.* 54 (1990) 848; *Bull. Acad. Sci. USSR, Phys. Ser.* 54 (1990) 31
- 1990LA06 J.B.J.M. Lanen, H.P. Blok, E. Jans, L. Lapikas, G. van der Steenhoven and P.K.A. de Witt Huberts, *Phys. Rev. Lett.* 64 (1990) 2250
- 1990LE24 D.R. Lehman, *J. Phys. (Paris) Colloq.* C6 (1990) 47
- 1990LI11 Li Xun-Gui and Chen Ke-Zhong, *Nuovo Cim.* A103 (1990) 387
- 1990LO14 R.G. Lovas, A.T. Kruppa and J.B.J.M. Lanen, *Nucl. Phys.* A516 (1990) 325
- 1990LU06 P. Lu and B.P. Nigam, *J. Phys.* G16 (1990) L135
- 1990MA10 J. Madsen, *Phys. Rev.* D41 (1990) 2472
- 1990MAZG Yu.G. Mashkarov, E.I. Koshchy, N.T. Burtebaev, A.D. Duisebaev, G.N. Ivanov, V.I. Kanashevich, V.A. Khaimin and V.V. Adodin, in *Leningrad 90* (1990) 318
- 1990MI10 J. Mildenberger, O. Hausser, R.G. Jeppesen, B. Larson, B. Pointon, A. Trudel, R. Henderson, K. Hicks, K.P. Jackson, A. Miller et al., *Phys. Rev.* C42 (1990) 732
- 1990MO10 A. Mondragon and E. Hernandez, *Phys. Rev.* C41 (1990) 1975
- 1990NAZZ A. Nadasen, B. Ashe, J. Brusoe, P. Schwandt, J. Winfield, G. Yoo, F.D. Becchetti, J. Brown, D. Hotz, J. Janecke et al., *Bull. Amer. Phys. Soc.* 35 (1990) 1667
- 1990PA25 B. Parker, K.K. Seth and R. Soundranayagam, *Phys. Lett.* B251 (1990) 483
- 1990RA05 R.D. Ransome, V.R. Cupps, S. Dawson, R.W. Ferguson, A. Green, C.L. Morris, J.A. McGill, J.R. Comfort, B.G. Ritchie, J. Tinsley et al., *Phys. Rev. Lett.* 64 (1990) 372
- 1990RA08 J. Rapaport, C.C. Foster, C.D. Goodman, C.A. Goulding, T.N. Taddeucci, D.J. Horen, E.R. Sugarbaker, C. Gaarde, J. Larsen, J.A. Carr et al., *Phys. Rev.* C41 (1990) 1920
- 1990RA20 R.D. Ransome, V.R. Cupps, S. Dawson, R.W. Ferguson, A. Green, C.L. Morris, J.A. McGill, J.R. Comfort, B.G. Ritchie, J.R. Tinsley et al., *Phys. Rev.* C42 (1990) 1500
- 1990RE09 R. Reichle, R. Behrisch and J. Roth, *Nucl. Instrum. Meth. Phys. Res.* B50 (1990) 68
- 1990RE11 M.P. Rekaló, *Sov. Phys. J.* 33 (1990) 409
- 1990RI01 K. Riisager, M.J.G. Borge, H. Gabelmann, P.G. Hansen, L. Johannsen, B. Jonson, W. Kurcewicz, G. Nyman, A. Richter, O. Tengblad et al., *Phys. Lett.* B235 (1990) 31
- 1990RIZX B.B. Ritchie, M.K. Brussel, N.R. Kolb and J.H. Smith, *Bull. Amer. Phys. Soc.* 35 (1990) 1679

- 1990RY07 G.G. Ryzhikh and Yu.M. Chuvilsky, *Izv. Akad. Nauk* 54 (1990) 2276; *Bull. Acad. Sci.* (1990) 188
- 1990SA05 S.S. Saad, N.Z. Darwish, F.M. El-Ashry and Kh.M. Omar, *Appl. Radiat. Isot.* 41 (1990) 211
- 1990SA47 F.D. Santos, I.J. Thompson and A.M. Eiro, *J. Phys. (Paris) Colloq.* C6 (1990) 443
- 1990SC15 A. Scalia, *Nuovo Cim.* A103 (1990) 85
- 1990SC22 A. Scalia, *Nuovo Cim.* A103 (1990) 927
- 1990SH1I Shaw et al., *Panic XII* (1990) Paper I-29
- 1990TA1I G. Tatara and T. Terasawa, *Prog. Theor. Phys.* 83 (1990) 552
- 1990TA1L Tacik et al., *Panic XII* (1990) Paper III-67
- 1990TR02 D.E. Trcka, A.D. Frawley, K.W. Kemper, D. Robson, J.D. Fox and E.G. Myers, *Phys. Rev.* C41 (1990) 2134
- 1990VA16 V.V. Varlamov, B.S. Ishkhanov and A.P. Chernyaev, *Izv. Akad. Nauk SSSR, Ser. Fiz.* 54 (1990) 561; *Bull. Acad. Sci. USSR, Phys. Ser.* 54 (1990) 181
- 1990VAZM V.V. Varlamov, B.S. Ishkhanov and A.P. Chernyaev, Program and Thesis, Proc. 40th Ann. Conf. Nucl. Spectrosc. Struct. At. Nucl., Leningrad (1990) 289
- 1990VE16 V.A. Vesna, I.S. Okunev, B.G. Peskov, E.V. Shulgina, A.D. Antonov, Yu. Andzheevsky, Yu.M. Gledenov, M.P. Mitrikov and Yu.P. Popov, *Pisma Zh. Eksp. Teor. Fiz.* 52 (1990) 550; *JETP Lett.* 52 (1990) 7
- 1990WA17 R.E. Warner, E. Cheung, C.F. Perdrisat, V. Punjabi, C.A. Davis, R. Helmer, A. Galonsky, L. Heilbronn, D. Krofcheck, S.E. Darden et al., *Phys. Rev.* C42 (1990) 2143
- 1990WA1J Wagner, *Prog. Part. Nucl. Phys.* 24 (1990) 17
- 1990YA09 T. Yamaya, S. Oh-ami, M. Fujiwara, T. Itahashi, K. Katori, M. Tosaki, S. Kato, S. Hatori and S. Ohkubo, *Phys. Rev.* C42 (1990) 1935
- 1990YA11 J. Yao, H. Sun, H. Lu, N. Dai and B. Qi, *Nucl. Phys.* A519 (1990) 602
- 1990ZH19 M.A. Zhusupov, *Izv. Akad. Nauk* 54 (1990) 2230; *Bull. Acad. Sci.* 54 (1990) 143
- 1990ZH1R X. Zhao, F. Zeng and Y. Ling, *High Energy Phys. Nucl. Phys.* 14 (1990) 85
- 1990ZI03 B. Ziegler, *Phys. Lett.* B237 (1990) 334
- 1991AB04 S. Abdel-Kariem, *Czech. J. Phys.* B41 (1991) 545
- 1991AR19 N. Ena, Seb. Cavallaro, P. D'Agostino, A. D'Arrigo, G. Fazio, G. Giardina, A. Italiano, R. Palamara and A. Taccone, *Few-Body Syst.* 10 (1991) 187
- 1991AR25 N. Arena, Seb. Cavallaro, A. D'Arrigo, G. Fazio, G. Giardina, A. Italiano, A. Taccone, V.D. Chesnokova, V.S. Olkhovsky and A.K. Zaichenko, *Nuovo Cim.* A104 (1991) 1809
- 1991BE05 C.A. Bertulani and M.S. Hussein, *Nucl. Phys.* A524 (1991) 306

- 1991BE16 A.S. Belousov, Ya.A. Vazdik, E.I. Malinovsky, S.V. Rusakov, P.A. Smirnov, Yu.V. Solovev, A.R. Terkulov, A.A. Tryasuchev, A.P. Usik and A.M. Fomenko, *Yad. Fiz.* 53 (1991) 609; *Sov. J. Nucl. Phys.* 53 (1991) 379
- 1991BL04 L.D. Blokhintsev, V.I. Kukulin, D.A. Savin and A.A. Sakharuk, *Yad. Fiz.* 53 (1991) 693; *Sov. J. Nucl. Phys.* 53 (1991) 433
- 1991BO1R E.T. Boschitz, *Few-Body Syst. Suppl.* 5 (1991) 191
- 1991BO48 M. Bozoian, *Nucl. Instrum. Meth. Phys. Res.* B56-57 (1991) 740
- 1991DA07 N.J. Davis, C.H. Shepherd-Themistocleous, A.C. Shotter, T. Davinson, E.W. Macdonald, D.G. Ireland, P.J. Sellin, P.J. Woods, O. Karban, G. Tungate et al., *J. Phys.* G17 (1991) L39
- 1991DA08 B.V. Danilin, M.V. Zhukov, S.N. Ershov, F.A. Gareev, R.S. Kurmanov, J.S. Vaagen and J.M. Bang, *Phys. Rev.* C43 (1991) 2835
- 1991DA24 B.V. Danilin and N.B. Shulgina *Izv. Akad. Nauk.* 55 (1991) 908; *Bull. Acad. Sci.* 55 (1991) 44.
- 1991FU02 Y. Fujiwara and Y.C. Tang, *Nucl. Phys.* A522 (1991) 459
- 1991GA26 V.B. Ganenko, V.A. Gushchin, Yu.V. Zhebrovsky, L.Ya. Kolesnikov, A.L. Rubashkin and P.V. Sorokin, *Yad. Fiz.* 54 (1991) 1495; *Sov. J. Nucl. Phys.* 54 (1991) 911
- 1991GL03 L. Glowacka, J. Turkiewicz, O.Yu. Goryunov, A.V. Mokhnach, O.A. Ponkratenko, A.T. Rudchik, V.K. Chernievsky, A.A. Shvedov, E.I. Koshchy and Yu.G. Mashkarov, *Nucl. Phys.* A534 (1991) 349
- 1991HA22 L. Harzheim, M.G. Huber and B.C. Metsch, *Z. Phys.* A340 (1991) 399
- 1991HI07 Y. Hirabayashi and Y. Sakuragi, *Phys. Lett.* B258 (1991) 11
- 1991HI11 Y. Hirabayashi, *Phys. Rev.* C44 (1991) 1581
- 1991KR02 V.M. Krasnopolsky, V.I. Kukulin, E.V. Kuznetsova, J. Horacek and N.M. Queen, *Phys. Rev.* C43 (1991) 822
- 1991KU09 Yu.A. Kuperin, D.M. Latypov, S.P. Merkurev, M. Bruno and F. Cannata, *Yad. Fiz.* 53 (1991) 942; *Sov. J. Nucl. Phys.* 53 (1991) 582
- 1991KU27 V.I. Kukulin, V.N. Pomerantsev, D.A. Savin and A.A. Sakharuk, *Izv. Akad. Nauk* 55 (1991) 81; *Bull. Acad. Sci.* 55 (1991) 76
- 1991LA1D L.M. Lazarev, *Ukr. Fiz. Zh.* 36 (1991) 661; *Ukr. J. Phys.* 36 (1991) 503
- 1991LU07 P. Lu and B.P. Nigam, *Nuovo Cim.* A104 (1991) 1313
- 1991MA56 Yu.G. Mashkarov, E.I. Koshchii, N.G. Burtebaev, A.D. Duisebaev, V.A. Adodin, Yu.M. Churil'skii, O.Yu. Goryunov and A.T. Rudchik, *Yad. Fiz.* 54 (1991) 629; *Sov. J. Nucl. Phys.* 54 (1991) 382
- 1991MI19 J.H. Mitchell, H.P. Blok, B.L. Berman, W.J. Briscoe, M.A. Daman, R. Ent, E. Jans, L. Lapikas and J.J.M. Steijger, *Phys. Rev.* C44 (1991) 2002

- 1991RI01 S. Ritt, E.T. Boschitz, R. Meier, R. Tacik, M. Wessler, K. Junker, J.A. Konter, S. Mango, D. Renker, B. van den Brandt et al., Phys. Rev. C43 (1991) 745
- 1991SA26 S.S. Saad, Appl. Radiat. Isot. 42 (1991) 827
- 1991SC23 A. Scalia, Nuovo Cim. A104 (1991) 691
- 1991SE06 K.K. Seth and B. Parker, Phys. Rev. Lett. 66 (1991) 2448
- 1991SH02 J. Shaw, T. Kobayashi, W. Clayton, L. Ghedira, D. Myers, P. Stoler, P.K. Teng, E.J. Winhold and J.H.J. Distelbrink, Phys. Rev. C43 (1991) 1800
- 1991SM01 R.J. Smith, J.J. Kolata, K. Lamkin, A. Morsad, K. Ashktorab, F.D. Becchetti, J.A. Brown, J.W. Janecke, W.Z. Liu and D.A. Roberts, Phys. Rev. C43 (1991) 761
- 1991SOZZ D.S. Sorenson, X. Aslanoglou, F.P. Brady, J.R. Drummond, R.C. Haight, C.R. Howell, N.S.P. King, A. Ling, P.W. Lisowski, C.L. Morris et al., Bull. Amer. Phys. Soc. 36 (1991) 1350, J11 6
- 1991SU03 Y. Suzuki, Nucl. Phys. A528 (1991) 395
- 1991TI04 M.A. Tiede, D.E. Trcka and K.W. Kemper, Phys. Rev. C44 (1991) 1698
- 1991TR02 V.A. Tryasuchev and A.V. Kolchin, Yad. Fiz. 53 (1991) 703; Sov. J. Nucl. Phys. 53 (1991) 439
- 1991TR1C V.A. Tryasuchev and A.I. Fiks, Sov. Phys. J. 34 (1991) 1025; Izv. Vyssh. Uchebn. Zaved. Fiz. 34 (1991) 92
- 1991TY01 S. Typel, G. Bluge, K. Langanke and W.A. Fowler, Z. Phys. A339 (1991) 249
- 1991TY02 S. Typel, G. Blüge and K. Langanke, Z. Phys. A339 (1991) 335
- 1991UN02 M. Unkelbach and H.M. Hofmann, Few-Body Syst. 11 (1991) 143
- 1991YO1C H. Yokota, in Tokyo 90 (1991) 385
- 1992AM1H A.I. Amelin, B.A. Chernyshev, M.G. Gornov, Yu.B. Gurov, P.V. Morokhov, V.A. Pechkurov, V.I. Savel'ev, R.R. Shafigullin, A.V. Shishkov and V.P. Koptev, in Penyscola (1992) 516
- 1992AR20 N. Arena, Seb. Cavallaro, A. D'Arrigo, G. Fazio, G. Giardina, A. Italiano and A. Taccone, J. Phys. G18 (1992) 2003
- 1992ARZX K.P. Artemov, V.Z. Goldverg, M.S. Golovkov, V.P. Rudakov, I.N. Serikov, V.A. Timofeev, R.W. Zurmuhle, D.R. Benton, Z. Liu, S.P. Barrow et al., in Dubna 92 (1992) 49
- 1992BA57 T.S. Bauer, Nucl. Phys. A546 (1992) 181c.
- 1992BLZX L.D. Blokhintsev, V.I. Kukulkin, E.V. Kuznetsova, A.A. Sakharuk and D.A. Savin, in Adelaide (1992) 74.
- 1992BO25 O.V. Bochkarev, A.A. Korshennikov, E.A. Kuzmin, I.G. Mukha, L.V. Chulkov and G.B. Yankov, Sov. J. Nucl. Phys. 55 (1992) 955

- 1992CL04 N.M. Clarke, *J. Phys.* G18 (1992) 917
- 1992CO05 L.M. Comere, L. Reber, K.W. Kemper, D. Robson, J.D. Brown and T.L. Talley, *Phys. Rev.* C45 (1992) 1803
- 1992CS04 A. Csoto and R.G. Lovas, *Phys. Rev.* C46 (1992) 576
- 1992DA1K A. D'Arrigo, G. Fazio, G. Giardina, A. Italiano, M. Lombardi, V.S. Olkhovsky, A. Taccone, V.D. Tchesnokova and A.K. Zaichenko, *Hadronic J.* 15 (1992) 303
- 1992DAZV B.V. Danilin, M.V. Zhukov, J.M. Bang, I.J. Thompson and J. S. Vaagen, in *Adelaide* (1992) 46
- 1992DE12 P. Descouvemont and C. Leclercqwillain, *J. Phys.* G18 (1992) L99
- 1992DU07 S.B. Dubovichenko and A.V. Dzhazairov-Kakhramanov, *Yad. Fiz.* 55 (1992) 2918; *Sov. J. Nucl. Phys.* 55 (1992) 1632
- 1992EL1A M. El-Shabshiry and A.T. Matar, *Indian J. Phys.* B66 (1992) 89
- 1992EN01 S. Engstler, G. Raimann, C. Angulo, U. Greife, C. Rolfs, U. Schroder, E. Somorjai, B. Kirch and K. Langanke, *Phys. Lett.* B279 (1992) 20
- 1992EN04 S. Engstler, G. Raimann, C. Angulo, U. Greife, C. Rolfs, U. Schroder, E. Somorjai, B. Kirch and K. Langanke, *Z. Phys.* A342 (1992) 471
- 1992ES04 A. Eskandarian and I.R. Afnan, *Phys. Rev.* C46 (1992) 2344
- 1992FU10 Y. Fujiwara and Y.C. Tang, *Few-Body Syst.* 12 (1992) 21
- 1992GA17 B.S. Galakhmatova, E.A. Romanovsky and K.V. Shitikova, *Bull. Russ. Acad. Sci. Phys.* 56 (1992) 91; *Izv. Ross. Akad. Nauk. Ser. Fiz.* 56 (1992) 47
- 1992GA18 S.A. Gaidenko, E.P. Kadkin S.N. Kondratyev, M.V. Pasechnik, V.S. Propenko, L.S. Saltykov, V.D. Sklyarenko, V.V. Tokarevsky and A.D. Fursa, *Bull. Russ. Acad. Sci. Phys.* 56 (1992) 136; *Izv. Ross. Akad. Nauk. Ser. Fiz.* 56 (1992) 156
- 1992GA27 F.A. Gareev, S. N. Ershov, E.F. Svinareva, B.V. Danilin, S.A. Fayans, D.V. Fedorov, M.V. Zhukov, S.A. Goncharov and J.S. Vaagen, *Europhys. Lett.* 20 (1992) 487
- 1992GLZX Yu.A. Glukhov, A.A. Ogloblin, O.Ya. Osadchy, S.B. Sakuta, D.V. Aleksandrov, A.S. Demyanova, B.G. Novatsky and D.N. Stepanov, in *Alma Ata* 92 (1992) 302
- 1992GO21 O.K. Gorpnich, V.I. Konfederatenko, V.V. Ostashko, O.M. Povoroznik, A.T. Rudchik and B.G. Struzhko, *Bull. Russ. Acad. Sci. Phys.* 56 (1992) 439
- 1992HE1E E. Hernandez and A. Mondragon, *Rev. Mex. Fis.* 38 Suppl. 1 (1992) 67
- 1992HI02 Y. Hirabayashi and Y. Sakuragi, *Nucl. Phys.* A536 (1992) 375
- 1992JO02 M. Jodice, S. Frullani, F. Garibaldi, F. Ghio, G.P. Capitani, E. DeSanctis, M. Bernheim, A. Gerard, A. Magnon, C. Marchand et al., *Phys. Lett.* B282 (1992) 31
- 1992JU1B K. Junker, in *Penyscola* (1992) 199
- 1992KA06 M. Kamal, V.T. Voronchev, V.I. Kukulkin, V.M. Krasnopolsky, Y. Nakao and K. Kudo, *J. Phys.* G18 (1992) 379

- 1992KH04 M.G. Khayat, N.S. Chant, P.G. Roos and T.-S.H. Lee, *Phys. Rev. C* 46 (1992) 2415
- 1992KO19 Y.E. Kozyr, *Bull. Russ. Acad. Sci. Phys.* 56 (1992) 448
- 1992KU16 Yu.A. Kuperin, D.M. Latypov and S.P. Merkurev, *Yad. Fiz.* 55 (1992) 2057; *Sov. J. Nucl. Phys.* 55 (1992) 1141
- 1992KU1G K. Kumar and A.K. Jain, *Pramana J. Phys.* 39 (1992) 71
- 1992LO09 M.A.K. Lodhi, A.Y. Abokor and M. Yusof Sulaiman, *Nuovo Cim. A* 105 (1992) 1257
- 1992LOZX M.A.K. Lodhi, P.M. Giancana and M.Y. Sulaiman, in *Adelaide* (1992) 100
- 1992NA02 Y. Nakai, M. Nakamura, H. Sakaguchi, H. Togawa, T. Nakano, S. Hirata, O. Kami-gaito, M. Iwaki, H.M. Shimizu, H. Kaneko et al., *Phys. Rev. C* 45 (1992) 451
- 1992OK01 A. Okihana, T. Konishi, R.E. Warner, D. Francis, M. Fujiwara, N. Matsuoka, K. Fukunaga, S. Kakigi, T. Hayashi, J. Kasagi et al., *Nucl. Phys. A* 549 (1992) 1
- 1992PE12 F. Pellegrini, G.F. Segato, A. Barbadoro, L. Corradi, M. Morando, P. Pavan and I. Gabrielli, *Phys. Rev. C* 46 (1992) 2354
- 1992PU03 V. Punjabic, F. Perdrisat, E. Cheung, J. Yonnet, M. Boivin, E. Tomasi-Gustafsson, R. Siebert, R. Frascaria, E. Warde, S. Belostotsky et al., *Phys. Rev. C* 46 (1992) 984
- 1992RA01 R.D. Ransome, C.L. Morris, V.R. Cupps, R.W. Ferguson, J.A. McGill, D.L. Watson, J.D. Zumbro, B.G. Ritchie, J.R. Comfort, J.R. Tinsley et al., *Phys. Rev. C* 45 (1992) R509
- 1992RA11 R.D. Ransome, C.L. Morris, M.K. Jones, B.G. Ritchie, D.L. Watson, J.A. McGill, K. Pujara, D.B. Clayton, I. Brown, P. Campbell and C.F. Moore, *Phys. Rev. C* 46 (1992) 273
- 1992RYZY G.G. Ryzhikh, R.A. Eramzhyan, V.I. Kukulín and Yu.M. Tchuvilsky, in *Adelaide* (1992) 38
- 1992SA01 C. Samanta, S. Ghosh, M. Lahiri, S. Ray and S.R. Banerjee, *Phys. Rev. C* 45 (1992) 1757
- 1992SO02 D.S. Sorenson, X. Aslanoglou, F.P. Brady, J.R. Drummond, R.C. Haight, C.R. Howell, N.S.P. King, A. Ling, P.W. Lisowski, B.K. Park et al., *Phys. Rev. C* 45 (1992) R500.
- 1992TA18 I. Tanihata, D. Hirata, T. Kobayashi, S. Shimoura, K. Sugimoto and H. Toki, *Phys. Lett. B* 289 (1992) 261
- 1992VA12 V.V. Varamov, A.E. Kosikhin, A.J. Ugaste and A.P. Chernjaev, *Bull. Russ. Acad. Sci. Phys.* 56 (1992) 126; *Izv. Ross. Akad. Nauk. Ser. Fiz.* 56 (1992) 143
- 1992WA18 R.E. Warner, A. Okihana, M. Fujiwara, N. Matsuoka, S. Hayashi, S. Kakigi, K. Fukunaga, J. Kasagi, M. Tosaki and M.B. Greenfield, *Phys. Rev. C* 46 (1992) 616
- 1992WI09 S. Winkler, H. Krauss, K. Grun, T. Rauscher, H. Oberhummer, H. Abele and G. Staudt, *J. Phys. G* 18 (1992) L147

- 1992YAZW T. Yamaya, M. Saitoh, K. Ishigaki, M. Fujiwara, T. Suehiro, S. Kato, K. Katori, M. Tanaka, S. Kubono and V. Guimaraes, Inst. Nucl. Study, Univ. Tokyo Ann. Rept. 1991 (1992) 16
- 1992ZH18 M.A. Zhusupov and E.T. Ibraeva, Bull. Russ. Acad. Sci. Phys. 56 (1992) 140; Izv. Ross. Akad. Nauk. Ser. Fiz. 56 (1992) 166
- 1993AL05 J.S. Al-Khalili, M.B. Barbaro and C. Wilkin, J. Phys. G19 (1993) 403
- 1993AM09 A.I. Amelin, M.N. Ber, M.G. Gornov, Yu.B. Gurov, S.V. Lapushkin, P.V. Morokhov, V.A. Pechkurov, B.A. Chernyshev, R.R. Shafigullin, A.V. Shishkov et al., Phys. At. Nucl. 56 (1993) 1297
- 1993AR12 N. Arena, S. Cavallaro, A. D'Arrigo, G. Fazio, G. Giardina, A. Italiano, A. Taccone, D.Q. Hung and V.S. Olkhovsky, Nuovo Cim. A106 (1993) 1007
- 1993BL09 L.D. Blokhintsev, V.I. Kukulín, A.A. Sakharuk, D.A. Savin and E.V. Kuznetsova, Phys. Rev. C48 (1993) 2390
- 1993BO24 M.J.G. Borge, L. Johannsen, B. Jonson, T. Nilsson, G. Nyman, K. Riisager, O. Tengblad and K.W. Rolander, Nucl. Phys. A560 (1993) 664
- 1993BO38 O.V. Bochkarev, A.A. Korshennikov, E.A. Kuzmin, I.G. Mukha, L.V. Chulkov and G.B. Yankov, Izv. Akad. Nauk Ser. Fiz. 57 (1993) 183; Bull. Russ. Acad. Sci. 57 (1993) 932
- 1993CA11 J.A. Caballero, T.W. Donnelly and G.I. Poulis, Nucl. Phys. A555 (1993) 709
- 1993CH06 W.T. Chou, E.K. Warburton and B.A. Brown, Phys. Rev. C47 (1993) 163
- 1993CS04 A. Csoto, Phys. Rev. C48 (1993) 165
- 1993DE07 V.V. Denyak, I.G. Evseev, V.P. Likhachev, S.A. Pashchuk and V.M. Khvastunov, Yad. Fiz. 56 (1993) 26; Phys. At. Nucl. 56 (1993) 14.
- 1993DU02 S.B. Dubovichenko and A.V. Dzhazairov-Kakhramanov, Yad. Fiz. 56 (1993) 87; Phys. At. Nucl. 56 (1993) 195
- 1993DU09 S.B. Dubovichenko, A.V. Dzhazairov-Kakhramanov and A.A. Sakharuk, Phys. At. Nucl. 56 (1993) 1044
- 1993FA01 L.R. Fawcett, Jr., Nucl. Sci. Eng. 113 (1993) 173
- 1993FE02 J. Feng, W.Q. Shen, Y.G. Ma and Z.Y. Zhu, Phys. Lett. B305 (1993) 9
- 1993FI06 G.F. Filippov, L. Truhilio and I.Y. Rybkin, Phys. At. Nucl. 56 (1993) 470
- 1993GLZZ Yu.A. Glukhov, A.A. Ogloblin, O.Ya. Osadchy, S.b. Sakuta, F.A. Gareev and S.N. Ershov, in Dubna 93 (1993) 275
- 1993GO06 S.A. Goncharov and A.A. Oglobin, Phys. At. Nucl. 56 (1993) 309
- 1993GO16 O.K. Gorpinich, Yu.N. Pavlenko, O.M. Povoroznik and B.G. Struzhko, Izv. Akad. Nauk Ser. Fiz. 57 (1993) 121; Bull. Russ Acad Sci. 57 (1993) 112

- 1993GU10 P. Guazzoni, M. Jaskola, L. Zetta, C.-Y. Kim, T. Udagawa and G. Bohlen, Nucl. Phys. A564 (1993) 425
- 1993IN01 C.H.Q. Ingram, Nucl. Phys. A553 (1993) 573c.
- 1993JA02 S. Jang, Phys. Rev. C47 (1993) 286.
- 1993KO33 Yu.E. Kozyr, Bull. Russ. Acad. Sci. 57 (1993) 148
- 1993KO44 M. Kohno, Phys. Rev. C48 (1993) 3122
- 1993KU27 V.I. Kukulín, G.G. Ryzhikh, Yu.M. Chuvilsky and R.A. Eramzhyan, Bull. Russ. Acad. Sci. Phys. 57 (1993) 1696
- 1993MA14 A. Mateos and N. Simicevic, Phys. Rev. C47 (1993) R1842
- 1993MA48 Yu.G. Mashkarov, E.I. Koshchy, I.I. Zalyubovsky, N.t. Burtebaev, A.D. Duisebaev, V.V. Adodin and A.T. Rudchik, Izv. Akad. Nauk Ser. Fiz. 57 (1993) 137; Bull. Acad. Russ. Sci. 57 (1993) 889
- 1993MU12 A.M. Mukhamedzhanov, Kh.D. Razikov, N.K. Timofeyud and R. Yarmukhamedov, Yad. Fiz. 56 (1993) Phys. At. Nucl. 56 (1993) 937
- 1993NA01 A. Nadasen, T. Stevens, J. Farhat, J. Brusoe, P. Schwandt, J.S. Winfield, G. Yoo, N. Anantaraman, F.D. Becchetti, J. Brown et al., Phys. Rev. C47 (1993) 674
- 1993OH01 H. Ohnuma, K. Hatanaka, S.I. Hayakawa, M. Hosaka, T. Ichihara, S. Ishida, S. Kato, T. Niizeki, M. Ohura, H. Okamura et al., Phys. Rev. C47 (1993) 648.
- 1993OK1A A. Okihana, T. Konishi and S. Kakigi, Bull. Inst. Chem. Res. Kyoto Univ. 71 (1993) 62
- 1993OK1B A. Okihana, R.E. Warner, M. Fujiwara, N. Matsuoka, K. Fukunaga, S. Kakigi, N. Koori and M. Tosaki, Bull. Inst. Chem. Res. Kyoto Univ. 71 (1993) 62
- 1993PE13 F. Petrovich, S.K. Yoon, M.J. Threapleton, R.J. Philpott, J.A. Carr, F.S. Dietrich and L.F. Hansen, Nucl. Phys. A563 (1993) 387
- 1993RE04 E.L. Reber, K.W. Kemper, P.L. Kerr, A.J. Mendez, E.G. Myers, B.G. Schmidt and N.M. Clarke, Phys. Rev. C47 (1993) 2190
- 1993RIZY K. Riisager, M.J.G. Borge, P.G. Hansen, B. Jonson, P. Moller, T. Nilsson, G. Nyman, O. Tengblad and K. Wilhelmsen, in Germany (1993) 311
- 1993RY01 G.G. Ryzhikh, R.A. Eramzhyan, V.I. Kukulín and Yu.M. Tchuvilsky, Nucl. Phys. A563 (1993) 247
- 1993SA10 C. Samanta, M. Lahiri, S. Roy, S. Ray and S.R. Banerjee, Phys. Rev. C47 (1993) 1313
- 1993SA35 S.B. Sakuta, A.A. Ogloblin, O.Y. Osadchy, Y.A. Glukhov, S.N. Ershov, F.A. Gareev and J.S. Vaagen, Europhys. Lett. 22 (1993) 511
- 1993SC30 N.W. Schellingerhout, L.P. Kok, S.A. Coon and R.M. Adam, Phys. Rev. C48 (1993) 2714; Erratum Phys. Rev. C52 (1995) 439
- 1993SH1G N.B. Shul'gina and B.V. Danilin, in Wein 92 (1993) 603

- 1993SI06 T. Sinha, S. Roy and C. Samanta, Phys. Rev. C47 (1993) 2994
- 1993SI09 T. Sinha, S. Roy and C. Samanta, Phys. Rev. C48 (1993) 785
- 1993ST06 S. Stamer, W. Scobel, W.B. Amian, R.C. Byrd, R.C. Haight, J.L. Ullmann, R.W. Bauer, M. Blann, B.A. Pohl, J. Bisplinghoff et al., Phys. Rev. C47 (1993) 1647
- 1993VE1A V.A. Vesna, I.S. Okunev, E.V. Shulgina, Yu.M. Gledenov, S.S. Parzhitskii and Yu.P. Popov, in Wein 92 (1993) 419
- 1993WAZX L. Wang, X. Yang, J. Rapaport, S. DeLucia, B. Luther, D. Marchlenski, E. Sugarbaker, C. Foster, C.D. Goodman, A. Smith et al., Bull. Amer. Phys. Soc. 38 (1993) 982
- 1993XI04 H. Xia, G. Shen, H. Tang, Z. Zhou, B. Qi, Z. Ke, and C. Zhou, Chin. J. Nucl. Phys. 15 (1993) 367
- 1993YAZZ X. Yang, L. Wang, J. Rapaport, S. DeLucia, B. Luther, D. Marchlenski, E. Sugarbaker, C. Foster, C.D. Goodman, A. Smith et al., Bull. Amer. Phys. Soc. 38 (1993) 1051
- 1993ZH09 M.V. Zhukov, B.V. Danilin, L.V. Grigorenko and N.B. Shul'gina, Phys. Rev. C47 (1993) 2937
- 1993ZH1J M.V. Zhukov, B.V. Danilin, D.V. Fedorov, J.M. Bang, I.J. Thompson and J.S. Vaagen, Phys. Rep. 231 (1993) 151
- 1994BA11 F.C. Barker, Phys. Lett. B322 (1994) 17
- 1994BB03 D. Baye, Y. Suzuki and P. Descouvemont, Prog. Theor. Phys. 91 (1994) 271
- 1994BI06 N. Bianchi, V. Muccifora, E. Desanctis, A. Fantoni, P.L. Sandri, V. Lucherini, E. Polli, A.R. Reolon, P. Rossi, M. Anghinolfi et al., Phys. Lett. B325 (1994) 333
- 1994BO04 J.G.L. Booten and A.G.M. Van Hees, Nucl. Phys. A569 (1994) 510
- 1994BO46 O.V. Bochkarev, A.A. Korshennikov, E.A. Kuzmin, I.G. Mukha, L.V. Chulkov and G.B. Yankov, Phys. At. Nucl. 57 (1994) 1281
- 1994BUZX N. Burtebaev, A. Duisebaev, G.N. Ivanov and S.B. Sakuta, in Kharkov 94 (1994) 221
- 1994BUZY N. Burtebaev, A. Duisebaev, G.N. Ivanov and S.B. Sakuta, in Kharkov 94 (1994) 220
- 1994CS01 A. Csoto and D. Baye, Phys. Rev. C49 (1994) 818
- 1994DE27 P. Descouvemont, Phys. Rev. C50 (1994) 2635
- 1994DE43 A.S. Demyanova, A.A. Ogloblin and O.Ya. Osadchy, Yad. Fiz. 57 (1994) 2025; Phys. At. Nucl. 57 (1994) 1949
- 1994DO32 V.N. Domnikov, D.Sh. Eleukenov, E.P. Kadkin, S.N. Kondratiev, S.V. Nevsky, O.F. Nemets, L.S. Saltykov, V.D. Sklyarenko, L.I. Slyusarenko, V.V. Tokarevsky et al., Bull. Russ. Acad. Sci. Phys. 58 (1994) 1910; Izv. Ross. Akad. Nauk Ser. Fiz. 58 (1994) 178

- 1994DOZW V.N. Domnikov, D.Sh. Eleukenov, E.P. Kadkin, S.N. Kondratev, O.F. Nemetz, S.V. Nevsky, L.S. Saltykov, V.D. Sklyarenko, L.I. Slyusarenko, V.V. Tokarevsky et al., in Kharkov 94 (1994) 250
- 1994DR11 M. Drosig, D.M. Drake and J. Masarik, Nucl. Instrum. Meth. Phys. Res. B94 (1994) 319
- 1994EL08 S. El-Sharkawy, Phys. Scr. 50 (1994) 97
- 1994EN04 R. Ent, B.L. Berman, H.P. Blok, J.F.J. Vandenbrand, W.J. Briscoe, M.N. Harakeh, E. Jans, P.D. Kunz and L. Lapikas, Nucl. Phys. A578 (1994) 93
- 1994FU04 S. Funada, H. Kameyama and Y. Sakuragi, Nucl. Phys. A575 (1994) 93
- 1994FU17 Y. Fujiwara and Y.C. Tang, Few-Body Syst. 16 (1994) 91
- 1994HE11 R. Henneck, G. Masson, P.D. Eversheim, R. Gebel, F. Hinterberger, U. Lahr, H.W. Schmitt, J. Schleeff and B.V. Przewoski, Nucl. Phys. A571 (1994) 541
- 1994IT04 N. Ito, M. Baba, S. Matsuyama, I. Matsuyama and N. Hirakawa, Nucl. Instrum. Meth. Phys. Res. A337 (1994) 474
- 1994KE08 N. Keeley, S.J. Bennett, N.M. Clarke, B.R. Fulton, G. Tungate, P.V. Drumm, M.A. Nagarajan and J.S. Lilley, Nucl. Phys. A571 (1994) 326
- 1994MO17 P. Mohr, V. Kolle, S. Wilmes, U. Atzrott, G. Staudt, J.W. Hammer, H. Krauss and H. Oberhummer, Phys. Rev. C50 (1994) 1543
- 1994NA03 A. Nadasen, J. Winfield, P. Schwandt, J. Farhat, L. Nieman, R.E. Warner, F.D. Becchetti, J.W. Jänecke and N. Anantaraman, Phys. Rev. C49 (1994) 2258
- 1994RA23 J. Rapaport, Nucl. Phys. A577 (1994) 83c.
- 1994RE01 E.L. Reber, K.W. Kemper, P.V. Green, P.L. Kerr, A.J. Mendez, E.G. Myers and B.G. Schmidt, Phys. Rev. C49 (1994) R1
- 1994RE15 E.L. Reber, K.W. Kemper, P.V. Green, P.L. Kerr, A.J. Mendez, E.G. Myers, B.G. Schmidt and V. Hnizdo, Phys. Rev. C50 (1994) 2917
- 1994RI06 S. Ritt, E. Boschitz, B. Brinkmüller, J. Bühler, R. Meier, M. Wessler, J.A. Konter, S. Mango, B. van den Brandt, S.S. Kamalov et al., Phys. Rev. C49 (1994) 3117
- 1994RU11 K. Rusek, N.M. Clarke and R.P. Ward, Phys. Rev. C50 (1994) 2010
- 1994RUZZ A.T. Rudchik, S.B. Sakuta and Yu.A. Glukhov, in Kharkov 94 (1994) 267
- 1994RY01 D. Ryckbosch, L. Van Hoorebeke, R. Van de Vyver, C. Van den Abeele, J. Dias, J.-O. Adler, K.I. Blomqvist, D. Nilsson, B. Schröder and K. Ziakas, Nucl. Phys. A568 (1994) 52
- 1994SA10 G.R. Satchler and W.G. Love, Phys. Rev. C49 (1994) 2254
- 1994SA32 C. Samanta, T. Sinha, S. Ghosh, S. Ray and S.R. Banerjee, Phys. Rev. C50 (1994) 1226

- 1994SA33 D.R. Sarker, M.A. Rahman, M. Rahman andn H.M.S. Gupta, *Nuovo Cim.* A107 (1994) 511
- 1994SA43 H. Sakai, M.B. Greenfield, K. Hatanaka, S. Ishida, N. Koori, H. Okamura, A. Okihana, H. Otsu, N. Sakamoto, Y. Satou et al., *Nucl. Phys.* A577 (1994) 111c.
- 1994SAZZ S.B. Sakuta, A.A. Ogloblin, O.Ya. Osadchy, Yu.A. Glukhov, S.N. Ershov and F.A. Gareev, in *Kharkov 94* (1994) 268
- 1994SH38 K. Shoda, O. Sasaki, K. Takeshita, T. Taniuchi and H. Tsubota, *J. Phys. Soc. Jpn.* 63 (1994) 478
- 1994SK01 M. Skalsey, *Phys. Rev.* C49 (1994) R620
- 1994SU02 Y. Suzuki, T. Kido, Y. Ogawa, K. Yabana and D. Baye, *Nucl. Phys.* A567 (1994) 957
- 1994TO08 K. Tomizawa, I. Arai, H. Kitayama, N. Kato, Y. Nagasaka, M. Tanaka, K. Yagi, J. Chiba, T. Kobayashi, A. Manabe et al., *Phys. Lett.* B328 (1994) 264
- 1994WA20 R.P. Ward, N.M. Clarke, K.I. Pearce, C.N. Pinder, C.O. Blyth, H.D. Choi, P.R. Dee, S. Roman, G. Tungate and N.J. Davis, *Phys. Rev.* C50 (1994) 918
- 1994WA22 L. Wang, X. Yang, J. Rapaport, C.D. Goodman, C.C. Foster, Y. Wang, J. Piekarewicz, E. Sugarbaker, D. Marchlenski, S. Delucia et al., *Phys. Rev.* C50 (1994) 2438
- 1994WE10 S. Weber, M. Kachelriess, M. Unkelbach and H.M. Hofmann, *Phys. Rev.* C50 (1994) 1492
- 1994ZH28 M.A. Zhusupov, E.T. Ibraeva, V.I. Kukulini and V.V. Peresyphkin, *Yad. Fiz.* 57 (1994) 2013; *Phys. At. Nucl.* 57 (1994) 1937
- 1994ZH34 M.A. Zhusupov, E.T. Ibraeva and V.V. Peresyphkin, *Izv. Akad. Nauk Ser. Fiz.* 58 (1994) 71; *Bull. Russ. Acad. Sci. Phys.* 58 (1994) 770
- 1995AR10 K. Arai, Y. Suzuki and K. Varga, *Phys. Rev.* C51 (1995) 2488
- 1995AR14 N. Arena, Seb. Cavallaro, P. D'Agostino, A. D'Arrigo, N.V. Eremin, G. Fazio, G. Giardina, M. Lombardi, M. Sacchi, T.U. Klochko et al., *Yad. Fiz.* 58 (1995) 215; *Phys. At. Nucl.* 58 (1995) 173
- 1995AR15 K.P. Artemov, M.S. Golovkov, V.V. Pankratov and V.P. Rudakov, *Yad. Fiz.* 58 (1995) 219; *Phys. At. Nucl.* 58 (1995) 177
- 1995AU04 G. Audi and A.H. Wapstra, *Nucl. Phys.* A595 (1995) 409
- 1995BE26 C.A. Bertulani and H. Sagawa, *Nucl. Phys.* A588 (1995) 667
- 1995BE60 Yu.A. Berezhnoi and V.V. Pilipenko, *Bull. Russ. Acad. Sci. Phys.* 59 (1995) 528
- 1995BO1H E. Boschitz, B. Brinkmoller, J. Buhler, R. Meier, S. Ritt, M. Wessler, J.A. Konter, S. Mango and B. van den Brandt, in *AIP Conf. Proc.* 334 (1995) 534
- 1995BU08 N.A. Burkova, V.V. Denyak, R.A. Ehramzhyan, I.G. Evseev, V.M. Khvastunov, V.P. Likhachev, S.A. Pashchuk and M.A. Zhusupov, *Nucl. Phys.* A586 (1995) 293

- 1995BU20 N. Burtebaev, A.D. Duisebaev, G.N. Ivanov and S.B. Sakuta, *Yad. Fiz.* 58 (1995) 596; *Phys. At. Nucl.* 58 (1995) 540
- 1995CA26 J. Carter, Z.Z. Vilakazi, R.W. Fearick, V. Hnizdo, E. Muskat, K.W. Kemper, D.E. Trcka and S.P. Van Verst, *Nucl. Phys.* A591 (1995) 349
- 1995CO05 M.D. Cortina-Gil, P. Roussel-Chomaz, N. Alamanos, F. Auger, J. Barrette, Y. Blumenfeld, J.M. Casandjian, M. Chartier, V. Fekou-Youmbi, B. Fernandez et al., *Nucl. Phys.* A583 (1995) 787c.
- 1995CO18 S.G. Cooper and R.S. Mackintosh, *Nucl. Phys.* A592 (1995) 338
- 1995DE06 P.R. Dee, C.O. Blyth, H.D. Choi, N.M. Clarke, S.J. Hall, O. Karban, I. Martel-Bravo, S. Roman, G. Tungate, R.P. Ward et al., *Phys. Rev.* C51 (1995) 492
- 1995DE53 H. Dennert, E. Aschenauer, W. Eyrich, A. Lehmann, M. Moosburger, N. Scholz, H. Wirth, H.J. Gils, H. Rebel and S. Zagromski, *Phys. Rev.* C52 (1995) 3195
- 1995DI01 J.F. Dias, D. Ryckbosch, R. Vandevyver, C. Vandenaabeele, G. Demeyer, L. Vanhoorebeke, J.O. Adler, K.I. Blomqvist, D. Nilsson, H. Ruijter et al., *Nucl. Phys.* A587 (1995) 434
- 1995DO23 B.C. Doyle and N.C. Mukhopadhyay, *Phys. Rev.* C52 (1995) 1947
- 1995DO24 B.C. Doyle, N.C. Mukhopadhyay and R.S. Wittmann, *Phys. Rev.* C52 (1995) 1957
- 1995DU12 S.B. Dubovichenko and A.V. Dzhazairov-Kakhramanov, *Yad. Fiz.* 58 (1995) 852; *Phys. At. Nucl.* 58 (1995) 788
- 1995EM03 A.V. Embulaev, V.K. Lukyanov and V.P. Permyakov, *Bull. Russ. Acad. Sci. Phys.* 59 (1995) 1876
- 1995ER1B R.A. Eramzhyan, G.G. Ryzhikh and S.S. Kamalov, in *Dubna 94* (1995) 645
- 1995FA21 G. Fazio, G. Giardina, O.Yu. Goryunov, A.A. Shvedov and R. Palamara, *J. Phys. Soc. Jpn.* 64 (1995) 1141
- 1995FO1J W. Fong, J.L. Matthews, M.L. Dowell, E.R. Kinney, S.A. Wood, P.A.M. Gram, G.A. Rebka, Jr. and D.A. Roberts, *Few-Body Syst. Suppl. (Austria)* 9 (1995) 187
- 1995FU11 Y. Fujiwara and Y.C. Tang, *Prog. Theor. Phys.* 93 (1995) 357
- 1995FU16 Y. Fujiwara and Y.C. Tang, *Prog. Theor. Phys. (Kyoto)* 93 (1995) 711
- 1995GA24 F.A. Gareev, S.N. Ershov, G.S. Kazacha, S.Yu. Shmakov and V.V. Uzhinsky, *Yad. Fiz.* 58 (1995) 620; *Phys. At. Nucl.* 58 (1995) 564
- 1995GU22 I.R. Gulamov, A.M. Mukhamedzhanov and G.K. Nie, *Phys. At. Nucl.* 58 (1995) 1689; *Yad. Fiz.* 58 (1995) 1789
- 1995HA56 P. G. Hansen, A.S. Jensen and B. Jonson, *Ann. Rev. Nucl. Part. Sci.* 45 (1995) 591
- 1995HI15 E. Hiyama and M. Kamimura, *Nucl. Phys.* A588 (1995) 35c.
- 1995IG06 S.B. Igamov and R. Yarmukhamedov, *Yad. Fiz.* 58 (1995) 1400; *Phys. At. Nucl.* 58 (1995) 1317.

- 1995IS1F Ye.I. Ismatov, Sh.Kh. Djuraev, A.V. Khugaev and D.E. Mannanov, in St. Petersburg XV (1995) 451
- 1995KA03 R. Kanungo, C. Samanta, S. Roy and S.K. Samaddar, Nucl. Phys. A581 (1995) 294
- 1995KA07 R. Kanungo, M. Lahiri, C. Samanta and H. Rebel, Z. Phys. A351 (1995) 9
- 1995KA1Y R. Kanungo, M. Lahiri and C. Samanta, H. Rebel, Rept. FZKA 5565 (1995) 23
- 1995KA43 R. Kanungo, M. Lahiri and C. Samanta, Int. J. Mod. Phys. E4 (1995) 827
- 1995KE10 P.L. Kerr, K.W. Kemper, P.V. Green, K. Mohajeri, E.G. Myers, D. Robson and B.G. Schmidt, Phys. Rev. C52 (1995) 1924
- 1995KH03 D.T. Khoa, G.R. Satchler and W. von Oertzen, Phys. Rev. C51 (1995) 2069
- 1995KO51 V.V. Komarov, A.M. Popova, M. El-Tahavi, F.I. Karmanov and V.L. Shablov, Bull. Russ. Acad. Sci. Phys. 59 (1995) 745
- 1995KU08 V.I. Kukulín, V.N. Pomerantsev, K.D. Razikov, V.T. Voronchev and G.G. Ryzhikh, Nucl. Phys. A586 (1995) 151
- 1995MA57 Yu.G. Mashkarov, E.I. Koshchy and Yu.M. Chuvilsky, Bull. Russ. Acad. Sci. Phys. 59 (1995) 150
- 1995MA59 M. Marinus and H.G. Miller, Nuovo Cim. A108 (1995) 437
- 1995MI16 D. Miljanic, S. Blagus, M. Lattuada, N. Soic and C. Spitaleri, Phys. Rev. C52 (1995) 1140
- 1995MU01 E. Muskat, J. Carter, R.W. Fearick and V. Hnizdo, Nucl. Phys. A581 (1995) 42
- 1995MU1J A.M. Mukhamedzhanov and R.E. Tribble, Few-Body Syst. Suppl. 8 (1995) 335
- 1995MU21 A.M. Mukhamedzhanov, R.P. Schmitt, R.E. Tribble and A. Sattarov, Phys. Rev. C52 (1995) 3483
- 1995OH03 H. Ohkura, T. Yamada and K. Ikeda, Prog. Theor. Phys. (Kyoto) 94 (1995) 47
- 1995PA22 Z. Papandreou, G.M. Huber, G.J. Lolos, J.C. Cormier, E.L. Mathie, S.I.H. Naqvi, D.F. Ottewell, R. Tacik, P.L. Walden, G. Jones et al., Phys. Rev. C51 (1995) R2862
- 1995PE1D Yu.E. Penionzkevich, C. Borcea, F. Carstoiu, I. David, Z. Dlouhy, A.S. Fomichev, D. Guillemaud-Mueller, M. Lewitowicz, S.M. Lukyanov, A.C. Mueller et al., in St. Petersburg XV (1995) 107
- 1995RI14 S. Rio, N. Metrich, M. Mosbah and P. Massiot, Nucl. Instrum. Meth. Phys. Res. B100 (1995) 141
- 1995RO37 C. Rolfs and E. Somorjai, Nucl. Instrum. Meth. Phys. Res. B99 (1995) 297
- 1995RU14 K. Rusek, N.M. Clarke, G. Tungate and R.P. Ward, Phys. Rev. C52 (1995) 2614
- 1995RY01 G.G. Ryzhikh, R.A. Eramzhyan and S. Shlomo, Phys. Rev. C51 (1995) 3240; Erratum Phys. Rev. C53 (1996) 2560
- 1995RY1C G.G. Ryzhikh, R.A. Eramzhyan and S.S. Kamalov, in Dubna 94 (1995) 302

- 1995SA12 S.S. Saad, *Appl. Radiat. Isot.* 46 (1995) 23
- 1995SK01 M. Skill, R. Baumann, G. Keil, N. Kniest, E. Pfaff, M. Preiss, G. Reiter, G. Clausnitzer, M. Haller and W. Kretschmer, *Nucl. Phys.* A581 (1995) 93
- 1995SU13 Y. Suzuki, K. Arai, Y. Ohbayasi and K. Varga, *Nucl. Phys.* A588 (1995) 15c.
- 1995WA01 R.E. Warner, F.D. Becchetti, J.W. Janecke, D.A. Roberts, D. Butts, C.L. Carpenter, J.M. Fetter, A. Muthukrishnan, J.J. Kolata, K. Lamkin et al., *Phys. Rev.* C51 (1995) 178
- 1995WA16 T. Wakasa, H. Sakai, H. Okamura, H. Otsu, S. Ishida, N. Sakamoto, T. Uesaka, Y. Satou, M.B. Greenfield, N. Koori et al., *Phys. Rev.* C51 (1995) R2871
- 1995WAZW T. Wakasa, H. Sakai, H. Okamura, H. Otsu, S. Fujita, M.B. Greenfield, S. Ishida, N. Koori, A. Okihana, N. Sakamoto et al., *RCNP (Osaka) Ann. Rept.* 1994 (1995) 153
- 1995XU02 H.M. Xu, G.K. Ajupova, A.C. Betker, C.A. Gagliardi, B. Kokenge, Y.W. Lui and A.F. Zaruba, *Phys. Rev.* C52 (1995) R1161.
- 1995YA12 X. Yang, L. Wang, J. Rapaport, C.D. Goodman, C.C. Foster, Y. Wang, E. Sugarbaker, D. Marchlenski, S. Delucia, B. Luther et al., *Phys. Rev.* C52 (1995) 2535
- 1996AL11 J.S. Al-Khalili, M.D. Cortina-Gil, P. Roussel-Chomaz, N. Alamanos, J. Barrette, W. Mittig, F. Auger, Y. Blumenfeld, J.M. Casandjian, M. Chartier et al., *Phys. Lett.* B378 (1996) 45
- 1996BB23 J. Ball, M. Combet, J.-L. Sans, B. Benda, P. Chaumette, J. Deregél, G. Durand, A.P. Dzyubak, C. Gaudron, F. Lehar et al., *Nucl. Instrum. Meth. Phys. Res.* A381 (1996) 4
- 1996BR30 J.A. Brown, D. Bazin, W. Benenson, J. Caggiano, M. Fauerbach, M. Hellstrom, J.H. Kelley, R.A. Kryger, R. Pfaff, B.M. Sherrill et al., *Phys. Rev.* C54 (1996) R2105
- 1996BU06 N. Burtebaev, A.D. Duisebaev, G.N. Ivanov and S.B. Sakuta, *Yad. Fiz.* 59 (1996) 33; *Phys. At. Nucl.* 59 (1996) 29.
- 1996CA01 F. Carstoiu and M. Lassaut, *Nucl. Phys.* A597 (1996) 269
- 1996CE02 F.E. Cecil, J. Yan and C.S. Galovich, *Phys. Rev.* C53 (1996) 1967
- 1996CH1C S. Cherubini, V.N. Kondratyev, M. Lattuada, C. Spitaleri, D. Miljanic, M. Zadro and G. Baur, *Astrophys. J.* 457 (1996) 855
- 1996CH33 S. Chiba and M. Harada, *J. Nucl. Sci. Technol.* 33 (1996) 346
- 1996CS03 A. Csoto and K. Langanke, *Nucl. Phys.* A601 (1996) 131
- 1996DA31 B.V. Danilin, M.V. Zhukov, N.B. Shulgina, I.J. Thompson, J.M. Bang, F.A. Gareev and J.S. Vaagen, *Bull. Russ. Acad. Sci. Phys.* 60 (1996) 21; *Izv. Ross. Akad. Nauk Ser. Fiz.* 60 (1996) 28
- 1996EF02 V.D. Efros, W. Balogh, H. Herndl, R. Hofinger and H. Oberhummer, *Z. Phys.* A355 (1996) 101

- 1996FO04 J.L. Forest, V.R. Pandharipande, S.C. Pieper, R.B. Wiringa, R. Schiavilla and A. Ariaga, *Phys. Rev. C* 54 (1996) 646
- 1996GA29 D.L. Gay, E.E. Bartosz, P.D. Cathers, D.D. Caussyn, T.L. Drummer, K.W. Kemper, P.L. Kerr and D. Robson, *Phys. Rev. C* 54 (1996) 3273
- 1996GR08 P.V. Green, K.V. Kemper, P.L. Kerr, K. Mohajeri, E.G. Myers, D. Robson, K. Rusek and I.J. Thompson, *Phys. Rev. C* 53 (1996) 2862
- 1996JA11 J. Janecke, T. Annakkage, G.P.A. Berg, B.A. Brown, J.A. Brown, G. Crawley, S. Danczik, M. Fujiwara, D.J. Mercer, K. Pham et al., *Phys. Rev. C* 54 (1996) 1070
- 1996JA12 L. Jarczyk, B. Kamys, M. Kistryn, A. Magiera, Z. Rudy, A. Strzalkowski, R. Barna, V. D'Amico, D. De Pasquale, A. Italiano et al., *Phys. Rev. C* 54 (1996) 1302
- 1996KE09 P.L. Kerr, K.W. Kemper, P.V. Green, K. Mohajeri, E.G. Myers, B.G. Schmidt and V. Hnizdo, *Phys. Rev. C* 54 (1996) 1267
- 1996KN02 O.M. Knyazkov, A.A. Kolozhvari, I.N. Kukhtina and S.A. Fayans, *Yad. Fiz.* 59 (1996) 466; *Phys. At. Nucl.* 59 (1996) 439
- 1996KUZU A.V. Kulik, *Yad. Fiz.* 59 (1996) 217; *Phys. At. Nucl.* 59 (1996) 199
- 1996LO04 G.J. Lolos, G.M. Huber, E.L. Mathie, S.I.H. Naqvi, Z. Papandreou, D.F. Ottewell, P.L. Walden, G. Jones, X. Aslanoglou and J.L. Visschers, *Phys. Rev. C* 54 (1996) 211
- 1996NA24 P. Navratil and B.R. Barrett, *Phys. Rev. C* 54 (1996) 2986
- 1996ORZZ H. Orihara, A. Terakawa, C.C. Yun, K. Itoh, A. Yamamoto, Y. Teramoto, N. Matsumura, T. Nakagawa, K. Ishii and H. Ohnuma, *Cyclotron Rad. Center, Tohoku Univ. Ann. Rept.* 1995 (1996) 28
- 1996RU10 A.T. Rudchik, A. Budzanowski, E.I. Koshchy, L. Glowacka, Y.G. Mashkarov, M. Makowskarzeszutko, V.M. Pirnak, R. Siudak, A. Szczurek, J. Turkiewicz et al., *Nucl. Phys. A* 602 (1996) 211
- 1996RU13 A.T. Rudchik, E.I. Koshchy, A. Budzanowski, R. Siudak, A. Szczurek, I. Skwirczynska, Yu.G. Mashkarov, L. Glowacka, J. Turkiewicz, I.I. Zalyubovsky et al., *Nucl. Phys. A* 609 (1996) 147
- 1996SA08 A. Saunders, S. Hoibraten, J.J. Kraushaar, B.J. Kriss, R.J. Peterson, R.A. Ristinen, J.T. Brack, G. Hofman, E.F. Gibson and C.L. Morris, *Phys. Rev. C* 53 (1996) 1745
- 1996SI13 T. Sinha, R. Kanungo, C. Samanta, S. Ghosh, P. Basu and H. Rebel, *Z. Phys. A* 355 (1996) 397
- 1996SO17 N. Soic, S. Blagus, M. Bogovac, S. Fazinic, M. Lattuada, M. Milin, D. Miljanic, D. Rendic, C. Spitaleri, T. Tadic and M. Zadro, *Europhys. Lett.* 34 (1996) 7
- 1996VE02 V.A. Vesna, Y.M. Gledenov, I.S. Okunev, Y.P. Popov and E.V. Shulgina, *Yad. Fiz.* 59 (1996) 23; *Phys. At. Nucl.* 59 (1996) 19.
- 1996YA01 T. Yamaya, K. Ishigaki, H. Ishiyama, T. Suehiro, S. Kato, M. Fujiwara, K. Katori, M.H. Tanaka, S. Kubono, V. Guimaraes and S. Ohkubo, *Phys. Rev. C* 53 (1996) 131

- 1996YA09 Y. Yamashita and Y. Kudo, Phys. Rev. C54 (1996) 2077
- 1997BR37 C.R. Brune, H.J. Karwowski and E.J. Ludwig, Nucl. Instrum. Meth. Phys. Res. A389 (1997) 421
- 1997CH24 L.V. Chulkov et al., Phys. Rev. Lett. 79 (1997) 201
- 1997CH47 L.V. Chulkov and G. Schrieder, Z. Phys. A359 (1997) 231
- 1997CO04 M.D. Cortina-Gil, P. Roussel-Chomaz, N. Alamanos, J. Barrette, W. Mittig, F. Auger, Y. Blumenfeld, J.M. Casandjian, M. Chartier, V. Fekou-Youmbi et al., Nucl. Phys. A616 (1997) 215c.
- 1997DA01 B.V. Danilin, T. Rogde, S.N. Ershov, H. Heiberg-Andersen, J.S. Vaagen, I.J. Thompson and M.V. Zhukov, Phys. Rev. C55 (1997) R577
- 1997DI01 J.F. Dias, D. Ryckbosch, R. Van de Vyver, C. Van den Abeele, G. De Meyer, L. Van Hoorebeke, J.-O. Adler, K.I. Blomqvist, D. Nilsson, H. Ruijter and B. Schroder, Phys. Rev. C55 (1997) 942
- 1997DO01 P.J. Dortmans, K. Amos and S. Karataglidis, J. Phys. G23 (1997) 183
- 1997DU02 S.B. Dubovichenko, Yad. Fiz. 60 (1997) 254; Phys. At. Nucl. 60 (1997) 195
- 1997DU15 S.B. Dubovichenko and A.V. Dzhazairov-Kakhramanov, Fiz. Elem. Chastits At. Yadra 28 (1997) 1529; Phys. Part. Nucl. 28 (1997) 615
- 1997ER05 S.N. Ershov, T. Rogde, B.V. Danilin, J.S. Vaagen, I.J. Thompson and F.A. Gareev, Phys. Rev. C56 (1997) 1483
- 1997FA17 W.R. Falk, R. Aryaeinejad, J.R. Campbell, D.B. Stetski, A.A. Mirzai, O.A. Abouzeid, T.L. Belyaeva and N.S. Zelenskaya, Nucl. Phys. A624 (1997) 370
- 1997KA24 S. Karataglidis, B.A. Brown, K. Amos and P.J. Dortmans, Phys. Rev. C55 (1997) 2826
- 1997KU14 E.V. Kuznetsova and V.I. Kukulín, Yad. Fiz. 60 (1997) 608; Phys. Atomic Nucl. 60 (1997) 528
- 1997NO04 K. M. Nollett, M. Lemoine and D.N. Schramm, Phys. Rev. C56 (1997) 1144
- 1997OK01 A. Okihana, K. Ushiro, T. Yoshimura, S. Kakigi and T. Sekioka, Nucl. Phys. A614 (1997) 71
- 1997PO03 K.W. Potthast, H. Brand, H. Freiesleben, P. Rosenthal, B. Kamys, H.P.G. Schieck and L. Sydow, Nuc. Phys. A614 (1997) 95
- 1997PU03 B.S. Pudliner, V.R. Pandharipande, J. Carlson, S.C. Pieper and R.B. Wiringa, Phys. Rev. C56 (1997) 1720
- 1997RU06 K. Rusek, P.V. Green, P.L. Kerr and K.W. Kemper, Phys. Rev. C56 (1997) 1895; Erratum Phys. Rev. C58 (1998) 1353
- 1997SA57 C. Samanta, Y. Sakuragi, M. Ito and M. Fujiwara, J. Phys. G23 (1997) 1697
- 1997SM07 A. Smerzi, D.G. Ravenhall and V.R. Pandharipande, Phys. Rev. C56 (1997) 2549

- 1997VA06 J.S. Vaagen, B.V. Danilin, S.N. Ershov, T. Rogde, D. Ridikas, H. Heilberg-Andersen, J.M. Bang, M.V. Zhukov, I.J. Thompson and the Russian-Nordic-British Theory Col-
lab., Nucl. Phys. A616 (1997) 426c.
- 1997WU01 J. Wurzer and H.M. Hofmann, Phys. Rev. C55 (1997) 688
- 1997YAZV Y. Yamashita and Y. Kudo, RCNP Ann. Rept. 1996 (1997) 113
- 1997ZA06 D. Zahnow, C. Rolfs, S. Schmidt and H.P. Trautvetter, Z. Phys. A359 (1997) 211
- 1998AH06 M. Ahmed, Md.A.E. Akhter, Md.A. Rahman, H.M. Sen Gupta and M. Rahman, Nuovo Cim. A111 (1998) 113
- 1998AL05 J.S. Al-Khalili and J.A. Tostevin, Phys. Rev. C57 (1998) 1846
- 1998AL10 D. Aleksandrov, T. Aumann, L. Axelsson, T. Baumann, M.J.G. Borge, L.V. Chulkov, J. Cub, W. Dostal, B. Eberlein, T.W. Elze et al., Nucl. Phys. A633 (1998) 234
- 1998AN02 M.A. Andreeva, I.M. Band, E.B. Karlsson, M.A. Listengarten and M.B. Trzhaskovskaya, Phys. Scr. 57 (1998) 142
- 1998BE09 G.F. Bertsch, K. Hencken and H. Esbensen, Phys. Rev. C57 (1998) 1366
- 1998BR10 C.R. Brune, W.H. Geist, H.J. Karwowski, E.J. Ludwig and K.D. Veal, Phys. Rev. C57 (1998) 3437
- 1998CE04 J. Cederberg, D. Olson, J. Larson, G. Rakness, K. Jarausch, J. Schmidt, B. Borovsky, P. Larson and B. Nelson, Phys. Rev. A57 (1998) 2539
- 1998CH33 S. Chiba, K. Togasaki, M. Ibaraki, N. Baba, S. Matsuyama, N. Hirakawa, K. Shibata, O. Iwamoto, A.J. Koning, G.M. Hale et al., Phys. Rev. C58 (1998) 2205
- 1998CO06 J.P. Connelly, B.L. Berman, W.J. Briscoe, K.S. Dhuga, A. Mokhtari, D. Zubanov, H.P. Blok, R. Ent, J.H. Mitchell and L. Lapikas, Phys. Rev. C57 (1998) 1569
- 1998CO19 M.D. Cortina-Gil, A. Pakou, N. Alamanos, W. Mittig, P. Roussel-Chomaz, F. Auger, J. Barrette, Y. Blumenfeld, J.M. Casandjian, M. Chartier et al., J. Phys. G24 (1998) 1547
- 1998CO1M M.D. Cortina-Gil, A. Pakou, N. Alamanos, W. Mittig, P. Roussel-Choamz, F. Auger, J. Barrette, Y. Blumenfeld, J.M. Casandjian, M. Chartier et al., in Dubna 97 (1998) 97
- 1998CO28 M.D. Cortina-Gil, A. Pakou, N. Alamanos, W. Mittig, P. Roussel-Chomaz, F. Auger, J. Barrette, Y. Blumenfeld, J.M. Casandjian, M. Chartier et al., Nucl. Phys. A641 (1998) 263
- 1998DO16 P.J. Dortmans, K. Amos, S. Karataglidis and J. Raynal, Phys. Rev. C58 (1998) 2249
- 1998DU03 S.B. Dubovichenko, Yad. Fiz. 61 (1998) 210; Phys. At. Nucl. 61 (1998) 162
- 1998FUZP H. Fujita, K. Kume and S. Hirenzaki, RCNP (Osaka) Ann. Rept. 1997 (1998) 216
- 1998GA37 E. Garrido, D.V. Fedorov and A.S. Jensen, Phys. Rev. C58 (1998) R2654
- 1998GL01 F. Gluck, Nucl. Phys. A628 (1998) 493

- 1998GO1J S.A. Goncharov, in Dubna 97 (1998) 114
- 1998HA24 S.S. Hanna, C.J. Martoff, D. Pocanic, K. Wang, R.C. Byrd, C.C. Foster and I.J. van Heerden, Nucl. Instrum. Meth. Phys. Res. A401 (1998) 345
- 1998IB02 M. Ibaraki, M. Baba, S. Matsuyama, T. Sanami, T. Win, T. Miura and N. Hirakawa, J. Nucl. Sci. Tech. 35 (1998) 843
- 1998KE03 N. Keeley and K. Rusek, Phys. Lett. B427 (1998) 1
- 1998KH06 A. Kharbach and P. Descouvemont, Phys. Rev. C58 (1998) 1066
- 1998MU12 A. Mukherjee, U.D. Pramanik, S. Chattopadhyay, M.S. Sarkar, A. Goswami, P. Basu, S. Bhattacharya, M.L. Chatterjee and B. Dasmahapatra, Nucl. Phys. A635 (1998) 305; Erratum Nucl. Phys. A640, 509 (1998)
- 1998NAZP S. Nakayama, K. Fushimi, N. Koori, H. Akimune, Y. Arimoto, I. Daito, H. Fujimura, M. Fujiwara, T. Inomata, K. Ishibashi et al., in Tokyo 97 (1998) 238
- 1998NAZR S. Nakayama, H. Akimune, Y. Arimoto, I. Daito, H. Fujimura, Y. Fujita, M. Fujiwara, K. Fushimi, H. Kohri, N. Koori et al., RCNP (Osaka) Ann. Rept. 1997 (1998) 61
- 1998OR1B H. Orihara, A. Terakawa, C.C. Yun, K. Itoh, A. Yamamoto, Y. Teramoto, N. Matsumura, G.C. Jon, T. Nakagawa, K. Ishii et al., in Tokyo 97 (1998) 489
- 1998PI02 V.V. Pilipenko, Yad. Fiz. 61 (1998) 467; Phys. At. Nucl. 61 (1998) 406
- 1998PO03 K.W. Potthast, H. Freiesleben, P. Rosenthal, B. Kamys, Z. Rudy, H. Paetz gen Schieck and L. Sydow, Nucl. Phys. A629 (1998) 656
- 1998SH33 V.B. Shostak, G.P. Palkin, N.I. Woloshin, V.P. Likachev, J.D.T. Arruda-Neto, M.T.F. da Cruz and M.N. Martins, Nucl. Phys. A643 (1998) 3
- 1998SU18 Y. Suzuki, N. Tanaka and K. Varga, J. Phys. G24 (1998) 1491
- 1998TE03 G.M. Ter-Akopian, A.M. Rodin, A.S. Fomichev, S.I. Sidorchuk, S.V. Stepantsov, R. Wolski, M.L. Chelnokov, V.A. Gorshkov, A. Yu. Lavrent'ev, V.I. Zagrebaev et al., Phys. Lett. B426 (1998) 251
- 1998TE1D G.M. Ter-Akopian, A.M. Rodin, A.S. Fomichev, S.I. Sidorchuk, S.V. Stepantsov, R. Wolski, M.L. Chelnokov, V.A. Gorshkov, A.Y. Lavrentev, V.B. Galinski et al., in Dubna 97 (1998) 105
- 1998TI06 D.R. Tilley, C.M. Cheves, J.H. Kelley, S. Raman and H.R. Weller, Nucl. Phys. A636 (1998) 249
- 1998VE03 K.D. Veal, C.R. Brune, W.H. Geist, H.J. Karwowski, E.J. Ludwig, A.J. Mendez, E.E. Bartosz, P.D. Cathers, T.L. Drummer, K.W. Kemper et al., Phys. Rev. Lett. 81 (1998) 1187
- 1998WA12 T. Wakasa, H. Sakai, H. Okamura, H. Otsu, S. Fujita, S. Ishida, N. Sakamoto, T. Uesaka, Y. Satou, T. Nonaka et al., Nucl. Instrum. Meth. Phys. Res. A404 (1998) 355
- 1998WI10 R.B. Wiringa, Nucl. Phys. A631 (1998) 70c.

- 1998WI28 R.B. Wiringa and R. Schiavilla, *Phys. Rev. Lett.* 81 (1998) 4317
- 1999AB37 B. Abu-Ibrahim, K. Fujimura and Y. Suzuki, *Nucl. Phys.* A657 (1999) 391
- 1999AN13 T. Annakkage, J. Janecke, J.S. Winfield, G.P.A. Berg, J.A. Brown, G. Crawley, S. DanczIk, M. Fujiwara, D.J. Mercer, K. Pham et al., *Nucl. Phys.* A648 (1999) 3
- 1999AN35 C. Angulo, M. Arnould, M. Rayet, P. Descouvemont, D. Baye, C. Leclercq-Willain, A. Coc, S. Barhoumi, P. Auger, C. Rolfs et al., *Nucl. Phys.* A656 (1999) 3
- 1999AR08 K. Arai, Y. Suzuki and R.G. Lovas, *Phys. Rev.* C59 (1999) 1432
- 1999AU01 T. Aumann, D. Aleksandrov, L. Axelsson, T. Baumann, M.J.G. Borge, L.V. Chulkov, J. Cub, W. Dostal, B. Eberlein, Th.W. Elze et al., *Phys. Rev.* C59 (1999) 1252
- 1999BB21 J. Ball, C.E. Allgower, M. Beddo, J. Bystricky, M. Combet, Ph. Demierre, G. Durand, J.-M. Fontaine, D. Grosnick, R. Hess et al., *Eur. Phys. J.* C11 (1999) 51
- 1999BE14 J.C. Bergstrom, R. Igarashi and J.M. Vogt, *Phys. Rev.* C59 (1999) 2588
- 1999CO11 S.G. Cooper, V.I. Kukulín, R.S. Mackintosh and V.N. Pomerantsev, *Phys. Rev.* C59 (1999) 2361
- 1999DE47 A. de Lesquen, C.E. Allgower, J. Ball, M. Beddo, J. Bystricky, M. Combet, Ph. Demierre, G. Durand, J.-M. Fontaine, D. Grosnick et al., *Eur. Phys. J.* C11 (1999) 69
- 1999EG02 P. Egelhof, *Pramana* 53 (1999) 365
- 1999ER02 R.A. Eramzhyan, G.G. Ryzhikh and Yu.M. Tchvilsky, *Yad. Fiz.* 62 (1999) 42; *Phys. At. Nucl.* 62 (1999) 37
- 1999FU03 K. Fujimura, D. Baye, P. Descouvemont, Y. Suzuki and K. Varga, *Phys. Rev.* C59 (1999) 817
- 1999GE02 E.A. George and L.D. Knutson, *Phys. Rev.* C59 (1999) 598
- 1999GN01 I.A. Gnilozub, G.G. Ryzhikh, R.A. Eramzhian and N.P. Yudin, *Bull. Russ. Acad. Sci. Phys.* 63 (1999) 1; *Izv. Ross. Akad. Nauk. Ser. Fiz.* 63 (1999) 2
- 1999GO36 O.K. Gorpínich, O.M. Povoroznik, A.P. Pshedzyal and B.G. Struzhko, *Bull. Russ. Acad. Sci. Phys.* 63 (1999) 1780; *Izv. Ross. Akad. Nauk. Ser. Fiz.* 63 (1999) 2298
- 1999HO02 T. Hotta, T. Tamae, T. Miura, H. Miyase, I. Nakagawa, T. Suda, M. Sugawara, T. Tadokoro, A. Takahashi, E. Tanaka and H. Tsubota, *Nucl. Phys.* A645 (1999) 492
- 1999LA13 L. Lapikas, J. Wesseling and R.B. Wiringa, *Phys. Rev. Lett.* 82 (1999) 4404
- 1999MA02 R.S. Mackintosh, S.G. Cooper and V.I. Kukulín, *Nucl. Phys.* A645 (1999) 399
- 1999MA16 A.M.M. Maciel, P.R.S. Gomes, J. Lubian, R.M. Anjos, R. Cabezas, G.M. Santos, C. Muri, S.B. Moraes, R. Liguori Neto, N. Added et al., *Phys. Rev.* C59 (1999) 2103
- 1999OG06 Yu.Ts. Oganessian, V.I. Zagrebaev and J.S. Vaagen, *Phys. Rev. Lett.* 82 (1999) 4996
- 1999OG09 Yu.Ts. Oganessian, V.I. Zagrebaev and J.S. Vaagen, *Phys. Rev.* C60 (1999) 044605

- 1999RA15 R. Raabe, A. Piechaczek, A. Andreyev, D. Baye, W. Bradfield-Smith, S. Cherubini, T. Davinson, P. Descouvemont, A. Di Pietro, W. Galster et al., Phys. Lett. B458 (1999) 1
- 1999RO13 O.A. Rondon, Phys. Rev. C60 (1999) 035201
- 1999SH05 K. Shoda and T. Tanaka, Phys. Rev. C59 (1999) 239
- 1999TI07 N.K. Timofeyuk, Nucl. Phys. A652 (1999) 132
- 1999VO01 A. Volya, S. Pratt and V. Zelevinsky, Phys. Rev. C59 (1999) 305
- 1999WAZV T. Wakasa, H. Sakai, K. Hatanaka, H. Okamura, H. Otsu, S. Fujita, T. Nonaka, T. Uesaka, Y. Satou, T. Ohnishi et al., RCNP (Osaka), Ann. Rept. 1998 (1999) p. 23
- 1999WO13 R. Wolski, A.S. Fomichev, A.M. Rodin, S.I. Sidorchuk, S.V. Stepantsov, G.M. Ter-Akopian, M.L. Chelnokov, V.A. Gorshkov, A. Yu. Lavrentev, Yu.Ts. Oganessian et al., Phys. Lett. B467 (1999) 8
- 1999ZHZN J. Zhang, B. Yu and Y. Han, INDC(CPR)-049/L (1999) 35
- 2000AB25 B.M. Abramov, Yu.A. Borodin, S.A. Bulychiev, I.A. Dukhovskoy, A.P. Krutenkova, V.V. Kulikov, M.A. Matsyuk, I.A. Radkevich, E.N. Turdakina and A.I. Khanov, Pisma Zh. Eksp. Teor. Fiz. 71 (2000) 524; JETP Lett. 71 (2000) 359
- 2000AL04 D. Aleksandrov, T. Aumann, L. Axelsson, T. Baumann, M.J.G. Borge, L.V. Chulkov, J. Cub, W. Dostal, B. Eberlein, Th.W. Elze et al., Nucl. Phys. A669 (2000) 51
- 2000AN15 M. Andersson, Chr. Bargholtz, K. Fransson, L. Holmberg, K. Lindh, L. Martensson, I. Sitnikova, P.-E. Tegner, P. Thorngren Engblom, G. Weiss et al., Phys. Lett. B481 (2000) 165; Erratum Phys. Lett. B484 (2000) 375
- 2000AN31 M. Andersson, Chr. Bargholtz, K. Fransson, L. Holmberg, K. Lindh, L. Martensson, I. Sitnikova, P.-E. Tegner, P. Thorngren Engblom, G. Weiss et al., Acta Phys. Pol. B31 (2000) 2343
- 2000ANZX L.N. Andronenko, M.N. Andronenko, D.M. Seliverstov and W. Neubert, in Croatia (2000) 370
- 2000AV02 M. Avrigeanu, G.S. Anagnostatos, A.N. Antonov and J. Giapitzakis, Phys. Rev. C62 (2000) 017001
- 2000BO45 D.V. Bolotov, O.M. Knyazkov, I.N. Kuchtina and S.A. Fayans, Yad. Fiz. 63 (2000) 1631; Phys. At. Nucl. 63 (2000) 1546
- 2000DE43 P.K. Deb, K. Amos and S. Karataglidis, Phys. Rev. C62 (2000) 037601
- 2000DE61 P.K. Deb, K. Amos and S. Karataglidis, Aust. J. Phys. 53 (2000) 767
- 2000DOZY A.V. Dobrovolsky, G.D. Alkhasov, M.N. Andronenko, A. Bauchet, P. Egelhof, S. Fritz, G.E. Gavrillov, H. Geissel, C. Gross, A.V. Khanzadeev et al., GSI 2000-1 (2000) 26
- 2000GA49 L. I. Galanina and N. S. Zelenskaya, Phys. At. Nucl. 63 (2000) 1792; Yad. Fiz. 63 (2000) 1881

- 2000GA59 L.I. Galanina and N.S. Zelenskaya, Bull. Russ. Acad. Sci. Phys. 64 (2000) 764; Izv. Ross. Akad. Nauk Ser. Fiz. 64 (2001) 954
- 2000GO35 O.K. Gorpinich, O.M. Povoroznik, A.P. Pshedzyal and B.G. Struzhko, Bull. Russ. Acad. Sci. Phys. 64 (2000) 82; Izv. Ross. Akad. Nauk. Ser. Fiz. 64 (2000) 100
- 2000GU19 D. Gupta, C. Samanta and R. Kanungo, Nucl. Phys. A674 (2000) 77
- 2000HA33 T. Hagner, R. von Hentig, B. Heisinger, L. Oberauer, S. Schonert, F. von Feilitzsch and E. Nolte, Astropart. Phys. 14 (2000) 33
- 2000IG03 S.B. Igamov and R. Yarmukhamedov, Nucl. Phys. A673 (2000) 509
- 2000ISZZ K. Ishii, K. Ochiai, I. Murata, H. Miyamaru and A. Takahashi, INDC(JPN)-185/U (JAERI-Conf 2000-005) (Jpn. Atomic Energy Res.) (2000)166
- 2000KO52 Yu.E. Kozyr, Bull. Russ. Acad. Sci. Phys. 64 (2000) 385; Izv. Ross. Akad. Nauk Ser. Fiz. (Russia) 64 (2000) 483
- 2000KO67 Yu.E. Kozyr, Bull. Russ. Acad. Sci. Phys. 64 (2000) 705; Izv. Ross. Akad. Nauk.Ser. Fiz. 64 (2000) 883
- 2000LA17 L. Lapikas, J. Wesseling and R.B. Wiringa, Nucl. Phys. A663-664 (2000) 377c.
- 2000LA40 L.M. Lazarev and B.M. Dzyuba, Bull. Russ. Acad. Sci. Phys. 64 (2000) 778; Izv. Ross. Akad. Nauk.Ser. Fiz. 64 (2000) 970
- 2000MA12 F.M. Marques, M. Labiche, N.A. Orr, J.C. Angelique, L. Axelsson, B. Benoit, U.C. Bergmann, M.J.G. Borge, W.N. Catford, S.P.G. Chappell et al., Phys. Lett. B476 (2000) 219
- 2000MA43 F. Marechal, T.L. Drummer and K.W. Kemper, Phys. Rev. C61 (2000) 064607
- 2000MI17 O.V. Miklukho, N.P. Aleshin, S.L. Belostotsky, O.G. Grebenyuk, O.Ya. Fedorov, A. A. Izotov, A.Yu. Kisselev, Yu.G. Naryshkin, V.V. Nelyubin et al., Yad. Fiz. 63 (2000) 894; Phys. At. Nucl. 63 (2000) 824
- 2000NA22 S. Nakayama, T. Yamagata, H. Akimune, I. Daito, H. Fujimura, Y. Fujita, M. Fujiwara, K. Fushimi, T. Inomata, H. Kohri et al., Phys. Rev. Lett. 85 (2000) 262
- 2000NA35 T. Nakamura, T. Aumann, D. Bazin, Y. Blumenfeld, B.A. Brown, J. Caggiano, R. Clement, T. Glasmacher, P.A. Lofy, A. Navin et al., Phys. Lett. B493 (2000) 209
- 2000RU03 K. Rusek and K.W. Kemper, Phys. Rev. C61 (2000) 034608
- 2000TI02 N.K. Timofeyuk and I.J. Thompson, Phys. Rev. C61 (2000) 044608
- 2000VO08 V.T. Voronchev and V.I. Kukulkin, J. Phys. G26 (2000) L103
- 2000WE03 S.P. Weppner, O. Garcia and Ch. Elster, Phys. Rev. C61 (2000) 044601
- 2000ZH40 W.N. Zhang, G.X. Tang, X.J. Chen, L. Huo, Y.M. Liu and S. Zhang, Phys. Rev. C62 (2000) 044903
- 2001AR05 K. Arai, P. Descouvemont and D. Baye, Phys. Rev. C63 (2001) 044611

- 2001AU06 S.M. Austin and D.J. Mercer, Nucl. Phys. A688 (2001) 70c
- 2001BA47 F.C. Barker and Y. Kondo, Nucl. Phys. A688 (2001) 959
- 2001BO38 M.J. Boland, M.A. Garbutt, R.P. Rassool, M.N. Thompson, A.J. Bennett, J.W. Jury, J.-O. Adler, B. Schroder, D. Nilsson, K. Hansen et al., Phys. Rev. C64 (2001) 031601
- 2001DE19 A. de Vismes, P. Roussel-Chomaz, W. Mittig, A. Pakou, N. Alamanos, F. Auger, J.-C. Angelique, J. Barrette, A.V. Belozyorov, C. Borcea et al., Phys. Lett. B505 (2001) 15
- 2001EG02 P. Egelhof for the IKAR Collaboration, Prog. Part. Nucl. Phys. 46 (2001) 307
- 2001LE01 T.-S.H. Lee and R.B. Wiringa, Phys. Rev. C63 (2001) 014006
- 2001ME13 D.J. Mercer, S.M. Austin, J.A. Brown, S.A. Danczyk, S.E. Hirzebruch, J.H. Kelley, T. Suomijarvi, D.A. Roberts and T.P. Walker, Phys. Rev. C63 (2001) 065805
- 2001MI07 O.V. Miklukho, N.P. Aleshin, S.L. Belostotsky, Yu.V. Elkin, O.G. Grebenyuk, O.Ya. Fedorov, A.A. Izotov, A.A. Jgoun, A.Yu. Kisselev, M.P. Levchenko et al., Nucl. Phys. A683 (2001) 145
- 2001NA18 S. Nakayama, Nucl. Phys. A687 (2001) 84c
- 2001NO01 K.M. Nollett, R.B. Wiringa and R. Schiavilla, Phys. Rev. C63 (2001) 024003
- 2001SH03 V.B. Shostak, G.P. Palkin, N.I. Woloshin, V.P. Likhachev, M.N. Martins and M.T.F. da Cruz, Phys. Rev. C63 (2001) 017602
- 2001TE03 F. Terrasi, L. Gialanella, G. Imbriani, F. Strieder, L. Campajola, A. D'Onofrio, U. Greife, G. Gyurky, C. Lubritto, A. Ordine et al., Nucl. Phys. A688 (2001) 539c
- 2001TH12 I.J. Thompson and A.M. Eiro, Nucl. Phys. A689 (2001) 365c