

# Energy Levels of Light Nuclei $A = 5$

F. Ajzenberg-Selove

*University of Pennsylvania, Philadelphia, Pennsylvania 19104-6396*

**Abstract:** An evaluation of  $A = 5-10$  was published in *Nuclear Physics A490* (1988), p. 1. This version of  $A = 5$  differs from the published version in that we have corrected some errors discovered after the article went to press. The introduction and introductory tables have been omitted from this manuscript. [Reference](#) key numbers have been changed to the NNDC/TUNL format.

(References closed June 1, 1988)

The original work of Fay Ajzenberg-Selove was supported by the US Department of Energy [DE-FG02-86ER40279]. Later modification by the TUNL Data Evaluation group was supported by the US Department of Energy, Office of High Energy and Nuclear Physics, under: Contract No. DEFG05-88-ER40441 (North Carolina State University); Contract No. DEFG05-91-ER40619 (Duke University).

## Table of Contents for $A = 5$

Below is a list of links for items found within the PDF document. The introductory [Table 2](#) is available on this website via the link.

A. Nuclides:  [\${}^5\text{n}\$](#) ,  [\${}^5\text{H}\$](#) ,  [\${}^5\text{He}\$](#) ,  [\${}^5\text{Li}\$](#) ,  [\${}^5\text{Be}\$](#)

B. Tables of Recommended Level Energies:

[Table 5.1](#): Energy levels of  ${}^5\text{He}$

[Table 5.3](#): Energy levels of  ${}^5\text{Li}$

C. [References](#)

D. Figures:  [\${}^5\text{He}\$](#) ,  [\${}^5\text{Li}\$](#) , [Isobar diagram](#)

E. Erratum to this Publication: [PS](#) or [PDF](#)

## ${}^5\mathbf{n}$

(Not illustrated)

${}^5\mathbf{n}$  has not been observed. It is suggested that it is unbound by 10 MeV: see (1984AJ01). See also (1984DE52).

## ${}^5\mathbf{H}$

(Not illustrated)

The  ${}^9\text{Be}({}^{11}\text{B}, {}^{15}\text{O})$  reaction at  $E({}^{11}\text{B}) = 52\text{--}76$  MeV shows no evidence for the formation of  ${}^5\text{H}$  (1986BE35, 1987BO40). For the earlier work see (1984AJ01). See also (1987KO47, 1988SEZJ). There is some evidence for the formation of a very broad ( $8 \pm 3$  MeV) state of  ${}^5\text{H}$  at  $E_x = 7.4 \pm 0.7$  MeV in the  ${}^9\text{Be}(\pi^-, \text{pt})$  reaction (1987GO25).  ${}^5\text{H}$  is calculated to have  $J^\pi = \frac{1}{2}^+$ , to be unstable with respect to two neutron emission and to have excited states at  $E_x = 2.44, 4.29$  and  $7.39$  MeV with  $J^\pi = \frac{5}{2}^+, \frac{3}{2}^+$ , and  $\frac{3}{2}^+$  [ $(0+1)\hbar\omega$  model space], and at  $E_x = 2.85, 3.46$  and  $6.02$  MeV with  $J^\pi = \frac{3}{2}^+, \frac{5}{2}^+$  and  $\frac{3}{2}^+$  [ $(0+2)\hbar\omega$  model space] (1985PO10). See also (1982SM09, 1986BE44, 1987PE1C) and (1983ANZQ; theor.).

## ${}^5\mathbf{He}$

(Figs. 1 and 3)

GENERAL: See also (1984AJ01).

*Model discussions:* (1983JA09, 1984VA06, 1984ZW1A, 1985FI1E, 1985GE06, 1985KW02, 1986KR12, 1988WO04).

*Special states:* (1982PO12, 1983VO02, 1984BE1B, 1984FI20, 1984GL1C, 1984VA06, 1984VAZS, 1984ZW1A, 1985BA68, 1985FI1E, 1987SV1A, 1988BA75, 1988KW02, 1988US1B).

*Electromagnetic transitions:* (1985FI1E).

*Astrophysical questions:* (1984SU1A, 1985BO1E).

*Complex reactions involving  ${}^5\text{He}$ :* (1985BO1J, 1985DE17, 1985PO11, 1986CS1A, 1986PO06, 1987BL1K, 1987BO40, 1987KI16, 1987PE1C).

*Reactions involving pions:* (1984DE52, 1985BE1C, 1985GE06, 1986CE04).

*Hypernuclei:* (1982KA1D, 1983BA1D, 1983BE1G, 1983MO1C, 1983SH1E, 1983SH38, 1984AS1D, 1984BO1A, 1984BO1H, 1984CH1G, 1984HU1B, 1984KO1F, 1984MI1E, 1984SH07, 1984SH1J, 1984ZH1B, 1985AH1A, 1985BA1F, 1985GI1E, 1985IK1A, 1985KO1G, 1985KU1A, 1985MO1F, 1985OS1C, 1985TA1E, 1985YA05, 1985YA1B, 1986AN1R, 1986BA1H, 1986BA1W, 1986BO1E, 1986CH1I, 1986DA1B, 1986DO1B, 1986LI1L, 1986MA1C, 1986SH1I, 1986SH1K, 1986SH1V,

1986SZ1A, 1986WA1J, 1986YA1F, 1987BO1L, 1987BO1O, 1987KA1Q, 1987MI38, 1987PO1H, 1987SH1H, 1987YA1C, 1987YA1M, 1988BA1G, 1988BO1E, 1988LA1B, 1988LI1C, 1988NO1A, 1988PO1H, 1988TA29).

Table 5.1: Energy levels of  ${}^5\text{He}$  <sup>a</sup>

$E_x$ (MeV) <sup>b</sup>	$J^\pi; T$	$\Gamma_{\text{c.m.}}$ (MeV)	Decay	Reactions
g.s.	$\frac{3^-}{2}; \frac{1}{2}$	$0.60 \pm 0.02$ <sup>a</sup>	n, $\alpha$	1, 4, 6, 7, 8, 9, 10, 11, 12, 13, 14, 15, 16, 17, 18, 19, 20, 21, 22, 23, 24, 25, 26, 27, 28, 29
$4 \pm 1$	$\frac{1^-}{2}; \frac{1}{2}$	$4 \pm 1$	n, $\alpha$	4, 6, 9, 10, 16, 20, 21, 29
$16.75 \pm 0.05$	$\frac{3^+}{2}; \frac{1}{2}$	$0.076 \pm 0.012$	$\gamma$ , n, d, t, $\alpha$	1, 2, 5, 6, 8, 10, 11, 12, 20, 21, 22
$19.8 \pm 0.4$ <sup>c</sup>	$(\frac{3}{2}, \frac{5}{2})^+; \frac{1}{2}$	$2.5 \pm 0.5$	n, d, t, $\alpha$	2, 3, 5, 8, 10, 12, 14, 18, 20, 21, 22
$24 - 25$ <sup>c</sup>		broad		20, 21
$(35.7 \pm 0.4)$		$\approx 2$		18, 22

<sup>a</sup> See Table 5.2 in (1966LA04) and Table 5.2 here. A study by G.M. Hale, D. Dodder and K. Witte on the  $S$ -matrix pole parameters for  ${}^5\text{He}$  is underway. I thank Dr. Hale for his comments concerning questions regarding  $R$ - and  $S$ -matrix calculations.

<sup>b</sup> Positive-parity states are predicted to lie at  $E_x \approx 5$  MeV ( $\frac{1}{2}^+$ ) and 12 MeV ( $\frac{3}{2}^+, \frac{5}{2}^+$ ): see (1988WO10).

<sup>c</sup> See the “States of  ${}^5\text{He}$ ” section in  ${}^5\text{He}$  in (1974AJ01).

Fig. 1: Energy levels of  ${}^5\text{He}$ . In these diagrams, energy values are plotted vertically in MeV, based on the ground state as zero. Uncertain levels or transitions are indicated by dashed lines; levels which are known to be particularly broad are cross-hatched. Values of total angular momentum  $J$ , parity, and isobaric spin  $T$  which appear to be reasonably well established are indicated on the levels; less certain assignments are enclosed in parentheses. For reactions in which  ${}^5\text{He}$  is the compound nucleus, some typical thin-target excitation functions are shown schematically, with the yield plotted horizontally and the bombarding energy vertically. Bombarding energies are indicated in laboratory coordinates and plotted to scale in cm coordinates. Excited states of the residual nuclei involved in these reactions have generally not been shown; where transitions to such excited states are known to occur, a brace is sometimes used to suggest reference to another diagram. For reactions in which the present nucleus occurs as a residual product, excitation functions have not been shown; a vertical arrow with a number indicating some bombarding energy, usually the highest, at which the reaction has been studied, is used instead. Further information on the levels illustrated, including a listing of the reactions in which each has been observed, is contained in the master table, entitled “Energy levels of  ${}^5\text{He}$ ”.

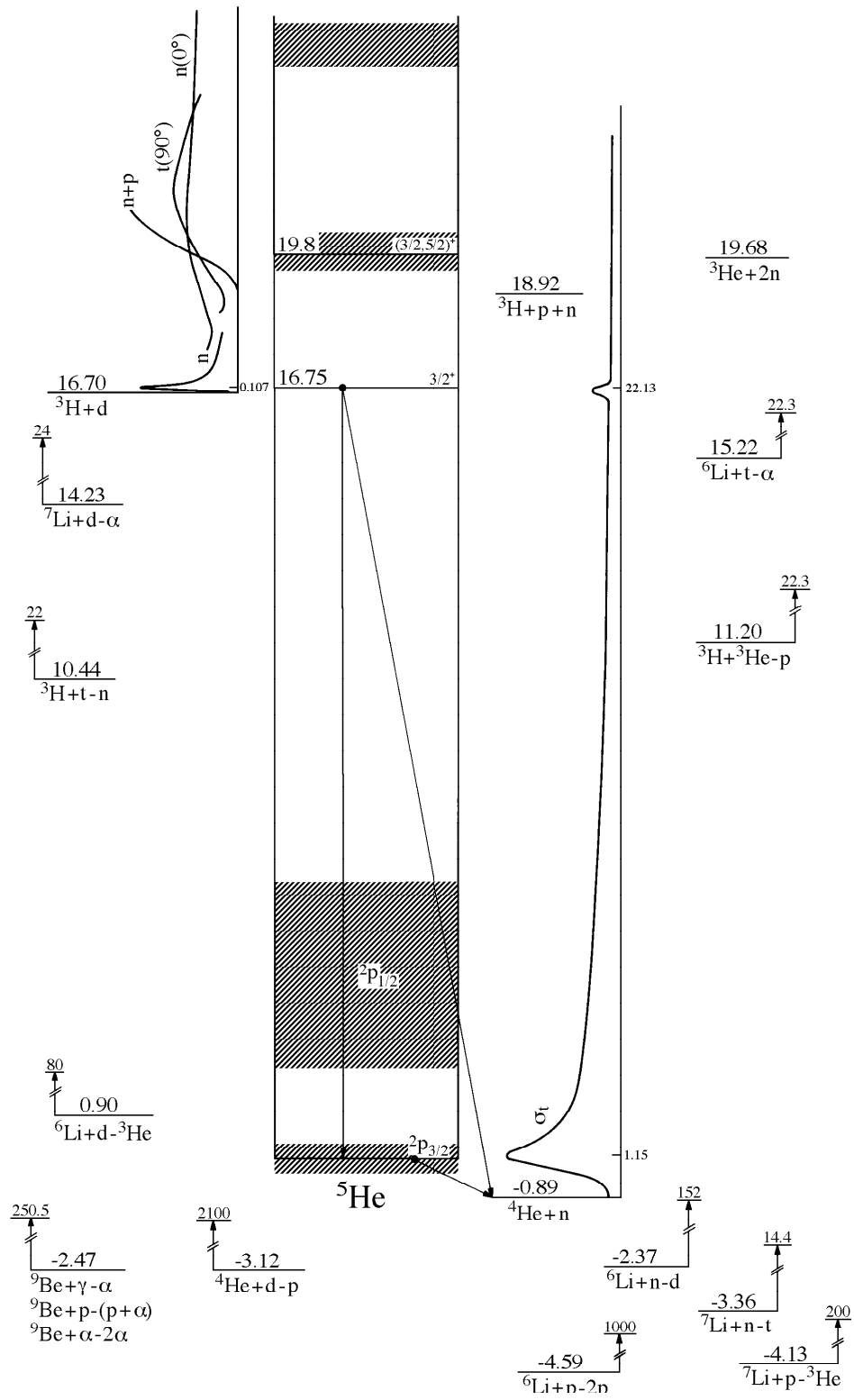

Other topics: (1983BE55, 1984BE1B, 1984PO11, 1985AN28, 1985GI1E, 1986BL1D, 1987SV1A, 1988KW02, 1988US1B).

Ground state of  ${}^5\text{He}$ : (1983ANZQ, 1984FR13, 1985AN28, 1985FI1E, 1985TA1F, 1985FA01, 1987SV1A, 1988WA08, 1988WO04).

1.  ${}^3\text{H}(d, \gamma){}^5\text{He}$   $Q_m = 16.70$

At low energies the reaction is dominated by a resonance at  $E_d = 107$  keV; the mirror reaction shows resonance at  $E_d = 430$  keV. The branching ratio  $\Gamma_{\gamma_0}/\Gamma_n$  integrated over the resonance from 0 to 275 keV is  $(5.6 \pm 0.6) \times 10^{-5}$  (1986MO05), in very good agreement with the earlier value of  $(5.4 \pm 1.3) \times 10^{-5}$  for  $E_d = 45$  to 146 keV (1984CE08). Assuming  $\Gamma_n$  of  ${}^5\text{He}^*(16.7)$  is  $37 \pm 5$  keV (see reaction 6), then  $\Gamma_{\gamma_0} = 2.1 \pm 0.4$  eV. (1986MO05) also report branching ratios up to  $E_d = 0.72$  MeV and summarize the earlier work to 5 MeV. For measurements of TAP and VAP at  $E_d = 0.4$  and 8.6 MeV, see (1987RIZZ; prelim.). See also (1985RIZZ), (1979AJ01) and (1984NE1B, 1986LA1F, 1988KI1C; applications).

2. (a)  ${}^3\text{H}(d, n){}^4\text{He}$   $Q_m = 17.5894$   $E_b = 16.70$

(b)  ${}^3\text{H}(d, 2n){}^3\text{He}$   $Q_m = -2.9883$

(c)  ${}^3\text{H}(d, pn){}^3\text{H}$   $Q_m = -2.2259$

The cross section has been measured in the range  $E_t = 12.5$  to 117 keV (1984JA08) [ $0.525(\pm 4.8\%)$  mb to  $3.739(\pm 1.4\%)$  b] and in the range  $E_d = 79.913$  to 115.901 keV ( $\pm 0.015$  keV) (1987BR10) [ $3.849$  to  $4.734$  b ( $\pm 1.6\%$ )]. See also (1985FI1G;  $E_d = 13.8$  to 114.3 keV). A strong resonance,  $\sigma$  (peak) = 4.88 b, appears at  $E_d = 105$  keV: see Table 5.2 in (1979AJ01) and (1987BR10). For a discussion of  $R$ -matrix analysis and evidence for a “shadow” pole, see (1987BR10, 1987HA20). See also (1987HA44, 1987MO1K). From  $E_d = 10$  to 500 keV, the cross section is well fitted with the assumption of s-wave formation of a  $J^\pi = \frac{3}{2}^+$  state. Measurements of cross sections and angular distributions for reaction (a) have been reported to  $E_d = 21$  MeV and  $E_t = 20.0$  MeV [see (1974AJ01, 1979AJ01, 1984AJ01)] as well as at 1.0, 1.5 and 2.0 MeV (1987LI07).

A study of reaction (a) with polarized deuterons at  $E_d = 0.2$  to 1.0 MeV indicates intervention of the s-wave,  $J^\pi = \frac{1}{2}^+$  channel, as well as possible p-waves above  $E_d = 0.3$  MeV. The polarization increases monotonically from 0.03 at  $E_d = 3$  MeV to  $\approx 0.5$  at  $E_d = 6.5$  MeV and then with a lower slope to 0.69 at  $E_d = 13$  MeV. The change in the slope may be caused by excited states of  ${}^5\text{He}$  near 20 MeV. Comparison with the  ${}^3\text{He}(d, p){}^4\text{He}$  mirror reaction at corresponding c.m. energies shows excellent agreement between the polarization values in the two reactions up to  $E_d = 6$  MeV, but then the proton polarization becomes  $\approx 15\%$  higher, converging back to the neutron values at  $E_d \approx 12$ –13 MeV. This may be due to experimental factors. Vector polarization transfer coefficients,  $K_y^{y'}$  ( $0^\circ$ ) have been measured for  $E_d = 5$  to 11 MeV (1985HOZU, 1986HO1E; prelim.). For other polarization work see (1984AJ01).

(1987BR10) have derived astrophysical  $S$ -factors in the range  $E_d = 79.9$  to  $115.9$  keV [ $S(0) = 11.71 \pm 0.08$  MeV  $\cdot$  b; multilevel fit], as well as reactivities. See (1984JA08) for the earlier work, and (1985CA41, 1987VA36).

Reaction (b) has been studied for  $E_d = 10.9$  to  $83$  MeV. A study of reaction (c) leads to the suggestion of a resonance at  $E_{c.m.} = 2.9 \pm 0.3$  MeV [ $E_x = 19.6$  MeV],  $\Gamma_{c.m.} = 1.9 \pm 0.2$  MeV, consistent with  $J^\pi = \frac{3}{2}^-$  [see, however, Table 5.1]: see (1974AJ01, 1979AJ01). See also (1983BAZP, 1984SLZZ, 1987GOZF), (1986BR20, 1986RA21) and (1984SHZK, 1985FIZW, 1986CO1J, 1986ILZZ, 1986KO21, 1986VAZU; theor.). For applications see (1983GO1C, 1983HU1A, 1984BA1D, 1984HU04, 1984MA71, 1984VL1A, 1986AL1H, 1986CA1E, 1986EN1A, 1986GR1H, 1986HA1N, 1986HA1V, 1986KE1H, 1986KN1A, 1986KU1G, 1986LE1F, 1986LO1B, 1986OK1B, 1986PA1G, 1986PE1H, 1986SA1M, 1986TA1K, 1986WI1B, 1987BA2I, 1987BO1Q, 1987KA1O, 1987LE1G, 1987SO1A, 1987WU1C, 1987ZW1A, 1988KU1E).

For recent developments in muon-catalyzed fusion see (1986JO1B, 1987BA2P, 1987BR1G) and (1983JO1B, 1983TA1C, 1984AN1A, 1984BA1V, 1984BR1G, 1984CA1B, 1987AC1A, 1987BA2L, 1987BE1Y, 1987BR1T, 1987CA1O, 1987NA1K, 1987PE1D), (1983PO1E, 1984AJ01, 1984AN1C, 1984CH1F, 1984HA1J, 1984KR1B, 1984MO1G, 1984OT1A, 1986BR1H, 1986JO1C, 1986KA1K, 1987BR1W, 1987JO1A, 1987PO1M) and (1983SG1A, 1984BU1E, 1984BY1B, 1984FI1F, 1984ME1B, 1985BA1G, 1985CO1C, 1985FR1D, 1985GO1E, 1985GU1G, 1985HI1A, 1985KA1C, 1985KA1N, 1985ME1C, 1985ME1D, 1985RA1B, 1985VA1B, 1986BL15, 1986BO1F, 1986CO1K, 1986DA1D, 1986HU1C, 1986JO1C, 1986KH1B, 1986ME1D, 1986TA1J, 1986TA1L, 1987AK1B, 1987BE1W, 1987CO1N, 1987CO1P, 1987CO1W, 1987KA1Z, 1987KO1R, 1987ME1E, 1987RA1L, 1987TA1I, 1987WY1A, 1988JA1C, 1988RO1G; theor.).

### 3. ${}^3\text{H}(d, d){}^3\text{H}$

$$E_b = 16.70$$

The elastic scattering has been studied for  $E_d = 2.6$  to  $11.0$  MeV: see (1984AJ01). The excitation curves show an interference at  $E_x \approx 19$  MeV and a broad ( $\Gamma > 1$  MeV) resonance corresponding to  $E_x = 20.0 \pm 0.5$  MeV, similar to that seen in  ${}^3\text{He}(d, d)$  [see  ${}^5\text{Li}$ ]. Together with data from  ${}^3\text{H}(d, n){}^4\text{He}$ , this work favors an assignment  $D_{3/2}$  or  $D_{5/2}$  with a mixture of doublet and quartet components (channel spin  $\frac{1}{2}$  and  $\frac{3}{2}$ ) if only one state is involved [any appreciable doublet component would, however, be in conflict with results from  ${}^7\text{Li}(p, {}^3\text{He}){}^5\text{He}$ ]. Measurements of differential cross section and analyzing power using polarized deuterons with  $E_d = 3.2$  to  $12.3$  MeV show resonance-like behavior in the vector analyzing power near  $E_d = 5$  MeV. The anomaly appears in the odd Legendre coefficients and is interpreted in terms of a  $(\frac{1}{2}, \frac{3}{2})^-$  excited state of  ${}^5\text{He}$  with  $E_x \approx 19.6$  MeV. Broad structure in the differential cross section near  $6$  MeV, principally in the even Legendre coefficients, corresponds to an even parity state  ${}^5\text{He}^*(20.0)$ . For other polarization measurements (and for references) see (1979AJ01). For d-t correlations see (1987PO03). See also “Complex reactions” in the  ${}^5\text{He}$  “GENERAL section” and (1981PL1A, 1983HAYX, 1986BO01; theor.).

4.  ${}^3\text{H}(t, n){}^5\text{He}$   $Q_m = 10.44$

At  $E_t = 0.5$  MeV, the reaction appears to proceed via three channels: (i) direct breakup into  ${}^4\text{He} + 2n$ , the three-body breakup shape being modified by the n-n interaction; (ii) sequential decay via  ${}^5\text{He}(0)$ ; (iii) sequential decay via a broad excited state of  ${}^5\text{He}$ . The width of  ${}^5\text{He}(0)$  is estimated to be  $0.74 \pm 0.18$  MeV. Some evidence is also shown for  ${}^5\text{He}^*$  at  $E_x \approx 2$  MeV,  $\Gamma \approx 2.4$  MeV: see (1979AJ01). See also  ${}^6\text{He}$  and (1986BA73; theor.).

5.  ${}^3\text{He}(t, p){}^5\text{He}$   $Q_m = 11.20$

Some evidence is reported at  $E_t = 22.25$  MeV for a broad state of  ${}^5\text{He}$  at  $E_x \approx 20$  MeV, in addition to a sharp peak corresponding to  ${}^5\text{He}^*(16.7)$ : see (1979AJ01). See also  ${}^6\text{Li}$ .

6.  ${}^4\text{He}(n, n){}^4\text{He}$   $E_b = -0.89$

The coherent scattering length (thermal, bound) is  $3.07 \pm 0.02$  fm,  $\bar{\sigma}_s = 0.76 \pm 0.01$  b. Total cross sections have been measured for  $E_n = 4 \times 10^{-4}$  eV to 150.9 MeV and at 10 GeV/c [see (1984AJ01)] and at  $E_n = 1.5$  to 40 MeV (1983HA20).

The total cross section has a peak of 7.6 b at  $E_n = 1.15 \pm 0.05$  MeV,  $E_{c.m.} = 0.92 \pm 0.04$  MeV, with a width of about 1.2 MeV: see (1966LA04). A second resonance is observed at  $E_n = 22.133 \pm 0.010$  MeV [ $\sigma_{\text{peak}} = 0.9$  b] with a total width of  $76 \pm 12$  keV and  $\Gamma_n = 37 \pm 15$  keV (1983HA20). Attempts to detect additional resonances in the total cross section have been unsuccessful: see (1966LA04).

The  $P_{3/2}$  phase shift shows strong resonance behavior near 1 MeV, while the  $P_{1/2}$  phase shift changes more slowly, indicating a broad  $P_{1/2}$  level at several MeV excitation. (1966HO07) have constructed a set of phase shifts for  $E_n = 0$  to 31 MeV,  $l = 0, 1, 2, 3$ , using largely p- $\alpha$  phase shifts. At the  $\frac{3}{2}^+$  state the best fit to all data is given by  $E_{\text{res}} = 17.669$  MeV  $\pm 10$  keV,  $\gamma_d^2 = 2.0$  MeV  $\pm 25\%$ ,  $\gamma_n^2 = 50$  keV  $\pm 20\%$  (see Table 5.2 in (1979AJ01)).

An  $R$ -function analysis of the  ${}^4\text{He} + n$  data below 21 MeV (including absolute neutron analyzing power measurement and accurate cross section measurements) has led to a set of phase shifts and analyzing powers which are based on the  ${}^4\text{He} + n$  data alone (rather than also including the  ${}^4\text{He} + p$  data). At  $r = 3.3$  fm the values obtained for the  $P_{1/2}$  and  $P_{3/2}$  resonances are, respectively,  $E_{c.m.} = 1.97$  and 0.77 MeV,  $\Gamma_{c.m.} = 5.22$  and 0.64 MeV: see (1984AJ01). Angular distributions of  $A_y$  have been studied by (1984KL05, 1984KR23, 1986KL04) for  $E_n = 15$  to 50 MeV: see also for phase-shift analysis and comparison with  ${}^4\text{He}(p, p)$ .

The excitation energies and the spectroscopic factors for  ${}^5\text{He}$  states are obtained by (1985BA68) from 2-level  $R$ -matrix fits to the phase shifts, as functions of the channel radius. For  $a \approx 5.1$  fm a very broad state with  $J^\pi = \frac{1}{2}^+$  is found to lie at  $E_x \approx 7$  MeV in both  ${}^5\text{He}$  and  ${}^5\text{Li}$ , in agreement with the shell-model calculation by (1984VA06). Broad  $\frac{3}{2}^+$  and  $\frac{5}{2}^+$  states then lie at  $\approx 14$  MeV



and the  $\frac{1}{2}^-$  state is at about 2.6 MeV. (1985BA68) suggest that the phase-shift analysis should be redone with values of  $a$  larger than those previously used ( $a \approx 3$  fm). See also (1984AJ01, 1984SI1A, 1985AL1D, 1985SI1B, 1985WI1B, 1986BA1Y), (1986BU1D, 1986DO1H; applications) and (1981PL1A, 1982AZ02, 1983DM01, 1983KU06, 1984BL21, 1984FI20, 1984SC1A, 1984SHZK, 1985HA04, 1985HO1B, 1985KI11, 1985MI1F, 1985NEZW, 1985SO06, 1985SO08, 1985SP05, 1985TI07, 1985TI08, 1986CA1K, 1986KO1J, 1986OK06, 1986WI04, 1987CA13, 1987DU1B, 1987HA44, 1987KR16, 1987MO1K, 1987PO1G, 1987QI01, 1987SH09, 1987SO04, 1987US1A, 1987VA36; theor.). For the breakup reaction see (1987MI1N, theor.).

$$7. \ ^4\text{He}(p, \pi^+)^5\text{He} \quad Q_m = -141.24$$

Differential cross sections have recently been reported at  $E_p = 201$  MeV (1985LE19) and at  $E_{\bar{p}} = 800$  MeV (1984HO01; also  $A_y$ ). See also (1987SO1C) and (1985GE06; theor.).

$$8. \ (a) \ ^4\text{He}(d, p)^5\text{He} \quad Q_m = -3.12$$

$$(b) \ ^4\text{He}(d, pn)^4\text{He} \quad Q_m = -2.22459$$

A typical proton spectrum (reaction (a)) consists of a peak corresponding to the formation of the ground state of  $^5\text{He}$ , plus a continuum of protons ascribed to reaction (b). A study of the latter reaction shows evidence for sequential decay via  $^5\text{He}^*(0, 16.7 \pm 0.1 [\Gamma = 80 \pm 30 \text{ keV}])$  and suggests some fine structure near  $E_x = 19$  MeV [see also reactions 12 and 20]: see (1979AJ01). Differential cross sections and VAP have been measured for the ground state group at  $E_{\bar{d}} = 5.4, 6.0, \text{ and } 6.8$  MeV (1985LU08; also TAP) and at 6 to 11 MeV (1985OS02). At  $E_{\alpha} = 28.3$  MeV tensor polarization measurements involving the ground state transitions to  $^5\text{He}$  (and  $^5\text{Li}$ ) deviate from theoretical predictions which assume charge symmetry (1985WI15). See also  $^6\text{Li}$  (1988PUZZ;  $E_{\bar{d}} = 2.1$  GeV) and (1985DO03, 1985NEZW, 1986KO1J, 1987FU10, 1987KA1M, 1987KUZI; theor.).

$$9. \ ^4\text{He}(^7\text{Li}, ^6\text{Li})^5\text{He} \quad Q_m = -8.14$$

(1988WO10) report a study of this reaction and of the  $^4\text{He}(^7\text{Li}, ^6\text{He})^5\text{Li}$  reaction at  $E(^7\text{Li}) = 50$  MeV, and of the  $^6\text{Li}(^{12}\text{C}, ^{13}\text{N})^5\text{He}$  and  $^6\text{Li}(^{13}\text{C}, ^{14}\text{C})^5\text{Li}$  reactions at  $E(\text{C}) = 90$  MeV. Properties of the two lowest states of  $A = 5$ , from  $R$ -matrix parameters ( $a = 5.5$  fm), are displayed in Table 5.2. Positive-parity states are then predicted to lie at  $E_x \approx 5$  MeV ( $\frac{1}{2}^+$ ) and 12 MeV ( $\frac{3}{2}^+, \frac{5}{2}^+$ ) in  $^5\text{He}$ - $^5\text{Li}$  (1988WO10).

Table 5.2:  $R$ -matrix values of the peak energy and FWHM of the  $\frac{3}{2}^-$  and  $\frac{1}{2}^-$  states of  ${}^5\text{He}$  and  ${}^5\text{Li}$  <sup>a</sup>

	$E_{\text{max}} (\frac{3}{2}^-)$		$\Gamma (\frac{3}{2}^-)$		$E_x (\frac{1}{2}^-)$		$\Gamma (\frac{1}{2}^-)$	
	${}^5\text{He}$	${}^5\text{Li}$	${}^5\text{He}$	${}^5\text{Li}$	${}^5\text{He}$	${}^5\text{Li}$	${}^5\text{He}$	${}^5\text{Li}$
<sup>b</sup>	$0.838 \pm 0.018$	$1.76 \pm 0.06$	$0.645 \pm 0.046$	$1.18 \pm 0.13$	$1.94 \pm 0.46$	$1.87 \pm 0.56$	$3.6 \pm 1.2$	$4.1 \pm 2.5$
<sup>c</sup>	$0.869 \pm 0.003$	$1.86 \pm 0.01$	$0.723 \pm 0.019$	$1.44 \pm 0.08$	$2.58 \pm 0.40$	$2.68 \pm 0.50$	$5.3 \pm 2.3$	$6.1 \pm 2.8$

<sup>a</sup> (1988WO10):  $a = 5.5$  fm. Energies are in MeV. See also footnote <sup>a</sup> to Table 5.1.

<sup>b</sup> Stripping reactions:  ${}^4\text{He}({}^7\text{Li}, {}^6\text{Li}){}^5\text{He}$  and  ${}^4\text{He}({}^7\text{Li}, {}^6\text{He}){}^5\text{Li}$ .

<sup>c</sup> Pickup reactions:  ${}^6\text{Li}({}^{12}\text{C}, {}^{13}\text{N}){}^5\text{He}$  and  ${}^6\text{Li}({}^{13}\text{C}, {}^{14}\text{C}){}^5\text{Li}$ .

10. (a)  ${}^6\text{Li}(\gamma, p){}^5\text{He}$   $Q_m = -4.59$   
 (b)  ${}^6\text{Li}(e, ep){}^5\text{He}$   $Q_m = -4.59$   
 (c)  ${}^6\text{Li}(\pi^+, \pi^+p){}^5\text{He}$   $Q_m = -4.59$

At  $E_\gamma = 60$  MeV, the proton spectrum shows two prominent peaks attributed to  ${}^5\text{He}^*(0 + 4.0, 20 \pm 2)$ : see (1979AJ01). The  $(\gamma, p_{0+1})$  cross section has been reported for  $E_\gamma = 34.5$  to 98.8 MeV. A broad secondary structure is also observed (1988CA11). In reaction (b) the missing energy spectrum show strong peaks due to  ${}^5\text{He}^*(0, 16.7)$  and possibly some strength in the region  $E_x = 5$ –15 MeV (1986LAZH; prelim.). See also  ${}^6\text{Li}$ . At  $E_{\pi^+} = 130$  and 150 MeV,  ${}^5\text{He}^*(0, 16.7)$  are populated (1987HU02).

11.  ${}^6\text{Li}(n, d){}^5\text{He}$   $Q_m = -2.37$

Angular distributions of  $d_0$  have been studied at  $E_n = 6.6$  to 56.3 MeV. At  $E_n = 56.3$  MeV angular distributions have also been obtained to  ${}^5\text{He}^*(16.7)$  and, possibly, to two higher states: see (1979AJ01, 1984AJ01). See also (1986BOZG).

12.  ${}^6\text{Li}(p, 2p){}^5\text{He}$   $Q_m = -4.59$

At  $E_p = 100$  MeV the population of  ${}^5\text{He}^*(0, 16.7)$  and possibly of a broad structure at  $E_x \approx 19$  MeV is observed: momentum distributions for  ${}^5\text{He}^*(0, 16.7)$  and angular correlation measurements are also reported. Recent work is reported at  $E_p = 47$  and 70 MeV (1983VD03), 70 MeV (1983GO06) and 1 GeV (1985BE30, 1985DO16). See also (1984AJ01).

13.  ${}^6\text{Li}(d, {}^3\text{He}){}^5\text{He}$   $Q_m = 0.90$

${}^5\text{He}_{\text{g.s.}}$  has been observed at  $E_{\text{d}} = 14.5$  MeV: see (1979AJ01).

14.  ${}^6\text{Li}(\alpha, \alpha\text{p}){}^5\text{He}$   $Q_{\text{m}} = -4.59$

At  $E_{\alpha} = 140$  MeV  ${}^5\text{He}^*(0, 20.0)$  are populated: see (1984AJ01).

15.  ${}^6\text{Li}({}^6\text{Li}, {}^7\text{Be}){}^5\text{He}$   $Q_{\text{m}} = 1.01$

Angular distributions have been obtained at  $E({}^6\text{Li})' = 156$  MeV to  ${}^5\text{He}_{\text{g.s.}}$ . Unresolved states at  $E_{\text{x}} = 16\text{--}20$  MeV are also populated (1987MI34).

16.  ${}^6\text{Li}({}^{12}\text{C}, {}^{13}\text{N}){}^5\text{He}$   $Q_{\text{m}} = -2.65$

See reaction 9 (1988WO10).

17.  ${}^7\text{Li}(\gamma, \text{d}){}^5\text{He}$   $Q_{\text{m}} = -9.62$

See  ${}^7\text{Li}$ .

18. (a)  ${}^7\text{Li}(\pi^+, 2\text{p}){}^5\text{He}$   $Q_{\text{m}} = 128.51$

(b)  ${}^7\text{Li}(\pi^-, 2\text{n}){}^5\text{He}$   $Q_{\text{m}} = 126.94$

Reaction (a) at  $E_{\pi^+} = 59.4$  MeV involves  ${}^5\text{He}^*(0, 4.)$  and a broad peak centered at  $E_{\text{x}} \approx 21$  MeV with  $\Gamma \approx 4$  MeV. It is not clear whether  ${}^5\text{He}^*(16.7)$  is populated (1986RI01). See also (1979AJ01, 1984AJ01).

19.  ${}^7\text{Li}(\text{n}, \text{t}){}^5\text{He}$   $Q_{\text{m}} = -3.36$

The angular distribution of  $t_0$  has been measured at  $E_{\text{n}} = 14.4$  MeV: see (1979AJ01) and  ${}^8\text{Li}$ . See also (1986BOZG).

20. (a)  ${}^7\text{Li}(p, {}^3\text{He}){}^5\text{He}$   $Q_m = -4.13$   
 (b)  ${}^7\text{Li}(p, pd){}^5\text{He}$   $Q_m = -9.62$

At  $E_p = 43.7$  MeV, angular distributions of the  ${}^3\text{He}$  groups to the ground state of  ${}^5\text{He}$  ( $\Gamma = 0.80 \pm 0.04$  MeV;  $L = 0+2$ ) and to levels at 16.7 MeV ( $L = 1$ ) and  $19.9 \pm 0.4$  MeV ( $\Gamma = 2.7$  MeV) have been studied. Since no transitions are observed in the  ${}^7\text{Li}(p, t){}^5\text{Li}$  reaction to the analog 20 MeV state in  ${}^5\text{Li}$  [see  ${}^5\text{Li}$ ], the transition is presumably  $S$ -forbidden and the states in  ${}^5\text{He}$ - ${}^5\text{Li}$  near 20 MeV are  ${}^4\text{D}_{3/2}$  or  ${}^4\text{D}_{5/2}$  [compare  ${}^3\text{H}(d, d)$ ]. Particle-particle coincidence data have been obtained at  $E_p = 43.7$  MeV. They suggest the existence of  ${}^5\text{He}^*(20.0)$  with  $\Gamma = 3.0 \pm 0.6$  MeV and of a broad state at  $\approx 25$  MeV. No  $T = \frac{3}{2}$  states decaying via  $T = 1$  states in  ${}^4\text{He}$  were observed: see (1979AJ01). In reaction (b)  ${}^5\text{He}^*(0 + 4, 16.7, 25)$  appear to be involved at  $E_p = 670$  MeV (1981ER10) while at 200 MeV some structure at  $E_x \approx 20$  MeV is reported in addition to the ground state (1986WA11).

21. (a)  ${}^7\text{Li}(d, \alpha){}^5\text{He}$   $Q_m = 14.23$   
 (b)  ${}^7\text{Li}(d, n)2\text{ }{}^4\text{He}$   $Q_m = 15.1216$

At  $E_d = 24$  MeV, the  $\alpha$ -particle spectrum from reaction (a) shows structures corresponding to the ground and 16.7 MeV states and to states at  $E_x \approx 20.2$  and 23.8 MeV with  $\Gamma \approx 2$  MeV and  $\approx 1$  MeV, respectively. Reaction (b) proceeds mainly via excited states of  ${}^8\text{Be}$  and  ${}^5\text{He}_{g.s.}$  and possibly as well  ${}^5\text{He}^*(4)$ : see (1979AJ01). See also (1987WA21) and  ${}^8\text{Be}$ .

22. (a)  ${}^7\text{Li}({}^3\text{He}, p\alpha){}^5\text{He}$   $Q_m = 8.73$   
 (b)  ${}^7\text{Li}({}^3\text{He}, {}^3\text{He}d){}^5\text{He}$   $Q_m = -9.62$

A kinematically complete experiment is reported at  $E({}^3\text{He}) = 120$  MeV. The cross section for reaction (b) is an order of magnitude greater than that for reaction (a). The missing mass spectrum for the composite of both reactions suggests the population of several states of  ${}^5\text{He}$ , in addition to  ${}^5\text{He}^*(0, 16.7, 20.0)$ , including a state at  $35.7 \pm 0.4$  MeV with a width of  $\approx 2$  MeV (1985FR01).

23. (a)  ${}^9\text{Be}(p, p\alpha){}^5\text{He}$   $Q_m = -2.47$   
 (b)  ${}^9\text{Be}(p, d{}^3\text{He}){}^5\text{He}$   $Q_m = -20.82$

Both reactions have been studied at  $E_p = 26.0$  to 101.5 MeV [see (1984AJ01)] and at  $E_p = 150.5$  MeV (1985WA13) [reaction (a)]. See also (1985VD03; theor.).

24.  ${}^9\text{Be}(d, {}^6\text{Li}){}^5\text{He}$   $Q_m = -9.92$

The angular distribution to  ${}^5\text{He}_{\text{g.s.}}$  has been measured at  $E_d = 13.6$  MeV (1984SH1F; prelim.).

25. (a)  ${}^9\text{Be}({}^3\text{He}, {}^7\text{Be}){}^5\text{He}$   $Q_m = -0.88$   
 (b)  ${}^9\text{Be}({}^3\text{He}, \alpha)2\text{ }{}^4\text{He}$   $Q_m = 19.0043$

See (1984AJ01). For reaction (b) see  ${}^8\text{Be}$  and (1987WA25).

26.  ${}^9\text{Be}(\alpha, 2\alpha){}^5\text{He}$   $Q_m = -2.47$

See (1984AJ01).

27.  ${}^{10}\text{B}(n, {}^5\text{He}){}^6\text{Li}$   $Q_m = -5.35$

See  ${}^6\text{Li}$ .

28.  ${}^{10}\text{B}(d, {}^7\text{Be}){}^5\text{He}$   $Q_m = -1.97$

An angular distribution has been measured at  $E_d = 13.6$  MeV involving  ${}^5\text{He}_{\text{g.s.}}$  and  ${}^7\text{Be}^*(0.43)$  (1983DO10).

29.  ${}^{11}\text{B}({}^7\text{Li}, {}^{13}\text{C}){}^5\text{He}$   $Q_m = 9.06$

At  $E({}^{11}\text{B}) = 88$  MeV a broad structure is observed at  $E_x = 5.2 \pm 0.3$  MeV,  $\Gamma = 2.0 \pm 0.5$  MeV (1987BEYI). See also (1988BEYJ).

<sup>5</sup>Li  
(Figs. 2 and 3)

GENERAL: See also (1984AJ01).

*Model discussions:* (1984ZW1A, 1985BA68, 1985FI1E, 1985KW02).

*Special states:* (1982PO12, 1983FE07, 1984BE1B, 1984FI20, 1984GL1C, 1984VAZS, 1984ZW1A, 1985BA68, 1985FI1E, 1985PO18, 1985PO19, 1985WI1A, 1987SV1A, 1988BA86, 1988KW02).

*Electromagnetic transitions:* (1985FI1E, 1987KR16).

*Astrophysical questions:* (1984BA74, 1984SU1A, 1985BO1E, 1986HU1D).

*Complex reactions involving <sup>5</sup>Li:* (1985PO18, 1985PO19, 1985WI1A, 1986BA2D, 1986CH10, 1986CS1A, 1986MA1V, 1986XU1B, 1987BL1K, 1987CH33, 1987CH32, 1987DE1O, 1987DU07, 1987FO08, 1987GA20, 1987GE1B, 1987HA45, 1987KI16, 1987LY04, 1987PE1B, 1988CEZZ, 1988SA09).

*Reactions involving pions:* (1981MC09, 1983SP06, 1985BA1H, 1985BE1C).

*Hypernuclei:* (1982KA1D).

*Other topics:* (1983BE55, 1984BE1B, 1985AN28, 1987DU09, 1987SV1A, 1988KW02).

*Ground state of <sup>5</sup>Li:* (1983ANZQ, 1985AN28, 1985FI1E, 1985TA1F, 1985FA01, 1985WI1A, 1987KR16, 1987SV1A, 1988WA08).

1. <sup>3</sup>He(d,  $\gamma$ )<sup>5</sup>Li  $Q_m = 16.39$

The ratio  $\Gamma_\gamma/\Gamma_{p\alpha}$  has been determined for  $E(^3\text{He}) = 63$  to 150 keV [ $E_{c.m.} = 25$  to 60 keV] by (1985CE13) by measuring simultaneously the  $\gamma$ -rays and the charged particles. Because of the large widths of the final states,  $\gamma_0$  and  $\gamma_1$  could not be resolved but the results are consistent with  $E_x = 3.0 \pm 1.0$  MeV for the excited state.  $\Gamma_{\gamma_0}/\Gamma_{p\alpha}$  is roughly constant for  $E_{c.m.} = 25$  to 60 keV at  $(4.5 \pm 1.2) \times 10^{-5}$  and  $\Gamma_{\gamma_1}/\Gamma_{p\alpha} = (8 \pm 3) \times 10^{-5}$  at  $E(^3\text{He}) = 150$  keV (1985CE13). For applications see (1985CE13, 1985CE16).

Excitation curves and angular distributions have been measured for  $E_d = 0.2$  to 5 MeV and  $E(^3\text{He}) = 2$  to 26 MeV. A broad maximum in the cross section is observed at  $E_d = 0.45 \pm 0.04$  MeV [<sup>5</sup>Li\*(16.66)].  $\sigma_{\gamma_0} = 21 \pm 4 \mu\text{b}$ ,  $\Gamma_{\gamma_0} = 5 \pm 1$  eV. The radiation at resonance is isotropic, consistent with s-wave capture. Study of  $\gamma_0$  and  $\gamma_1$  yields  $\Gamma = 2.6 \pm 0.4$  MeV for the ground-state width, and  $E_x = 7.5 \pm 1.0$  MeV,  $\Gamma = 6.6 \pm 1.2$  MeV for the  $\frac{1}{2}^-$  state: see (1974AJ01). An excess in the cross section at higher bombarding energies is interpreted as being due to a state at  $E_x \approx 18$  MeV: even parity is deduced from the relative intensity of  $\gamma_0$  and  $\gamma_1$ . A broad peak is also observed at  $E_x \approx 20.7$  MeV in the  $\gamma_0$  cross section. The cross section for  $\gamma_1$  is  $\approx 0$ .

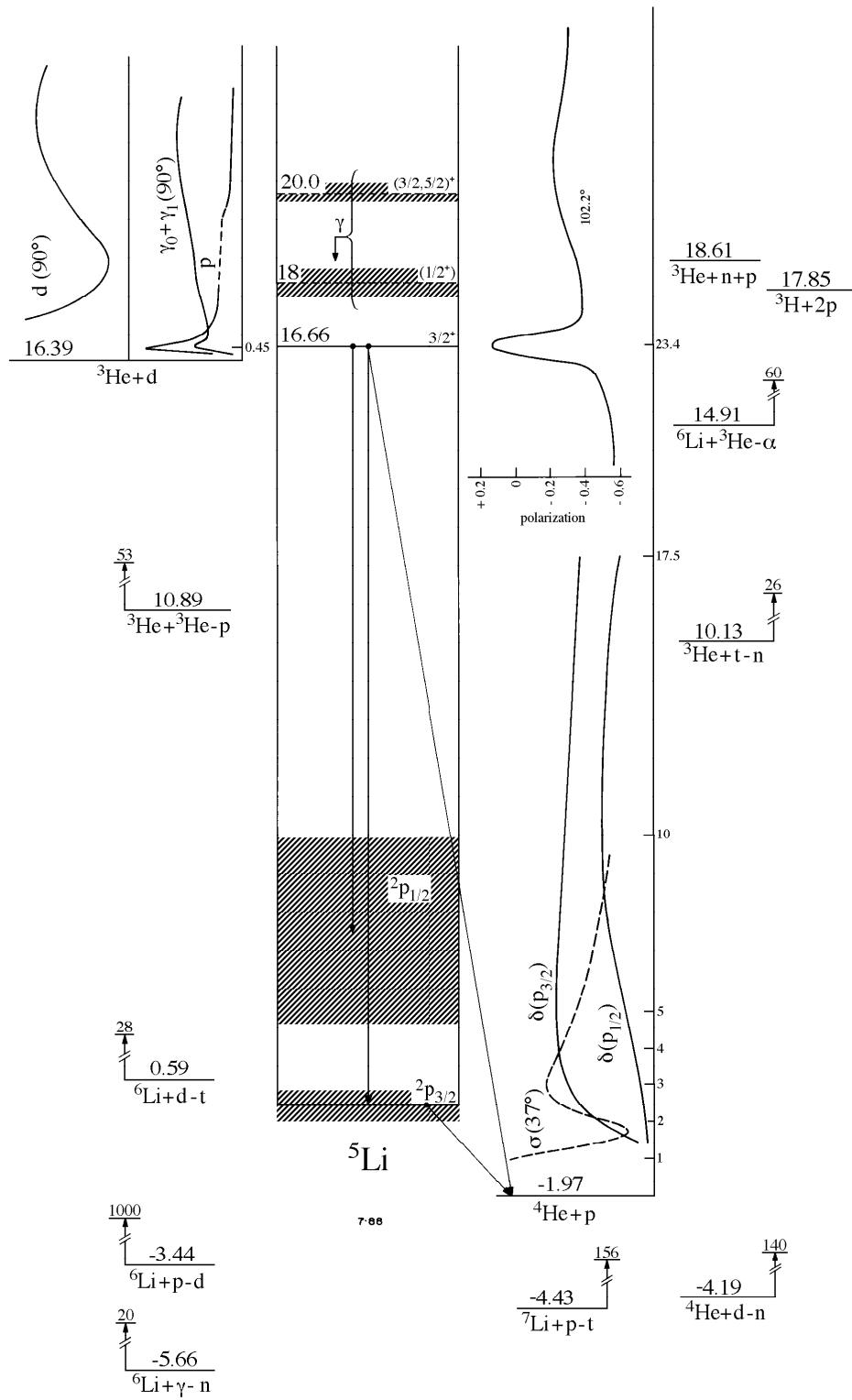

Fig. 2: Energy levels of  ${}^5\text{Li}$ . For notation see Fig. 1.

Table 5.3: Energy levels of  ${}^5\text{Li}$ 

$E_x$ (MeV) <sup>a</sup>	$J^\pi; T$	$\Gamma_{\text{c.m.}}$ (MeV)	Decay	Reactions
g.s.	$\frac{3}{2}^-; \frac{1}{2}$	$\approx 1.5$	p, $\alpha$	1, 4, 5, 6, 7, 8, 9, 10, 11, 12, 13, 14, 15, 16, 17, 18, 19, 20, 21, 22, 23
5 – 10	$\frac{1}{2}^-; \frac{1}{2}$	$5 \pm 2$	p, $\alpha$	1, 6, 10, 11, 13, 14, 15, 17, 18
$16.66 \pm 0.07$	$\frac{3}{2}^+; \frac{1}{2}$	$\approx 0.3$	$\gamma$ , p, d, ${}^3\text{He}$ , $\alpha$	1, 2, 3, 6, 13, 15, 18
$(18 \pm 1)$ <sup>a</sup>	$(\frac{1}{2}^+); \frac{1}{2}$	broad	$\gamma$ , p, d, ${}^3\text{He}$ , $\alpha$	1, 2, 13
$(20.0 \pm 0.5)$ b	$(\frac{3}{2}, \frac{5}{2})^+; \frac{1}{2}$	$\approx 5$	$\gamma$ , p, d, ${}^3\text{He}$ , $\alpha$	1, 2, 3, 4, 6, 13, 15
(34)		$\approx 4$		18, 19

<sup>a</sup> See also Table 5.2. Positive-parity states are predicted to lie at  $E_x \approx 5$  MeV ( $\frac{1}{2}^+$ ) and 12 MeV ( $\frac{3}{2}^+, \frac{5}{2}^+$ ): see (1988WO10).

<sup>b</sup> For possible additional states see reactions 2 and 18.

The observations are consistent with  $J^\pi = \frac{5}{2}^+$ : angular distributions appear to require at least one other state with significant strength near 19 MeV: see (1974AJ01). For cross section and analyzing power measurements for  $E_d = 4$  to 9 MeV see (1985RIZZ; prelim.).

2. (a) ${}^3\text{He}(d, p){}^4\text{He}$	$Q_m = 18.35319$	$E_b = 16.39$
(b) ${}^3\text{He}(d, np){}^3\text{He}$	$Q_m = -2.22458$	
(c) ${}^3\text{He}(d, 2p){}^3\text{H}$	$Q_m = -1.46083$	
(d) ${}^3\text{He}(d, 2d){}^1\text{H}$	$Q_m = -5.49353$	

Excitation functions and angular distributions have recently been measured for  $E_{\text{c.m.}} = 6.95$  to 171.3 keV, and  $S(E)$  have been deduced:  $S(0) = 6.3 \pm 0.6$  MeV  $\cdot$  b (1987KR18). See also (1984AJ01). Recently,  $S$ -factors have been obtained down to  $E_{\text{c.m.}} = 5.88$  keV. The effect on  $S$  of electron screening at low energies has been studied by (1988EN03).

A pronounced resonance occurs at  $E_d = 430$  keV,  $\Gamma \approx 450$  keV. The peak cross section is  $695 \pm 14$  mb: see Table 5.2 in (1979AJ01). Excitation functions for ground-state protons have also been reported for  $E({}^3\text{He}) = 0.39$  to 2.15 MeV and 18.7 to 44.1 MeV and for  $E_d = 2.8$  to 17.8 MeV [see (1974AJ01)]. Angular distributions have been measured for  $E_d = 0.25$  to 27 MeV



and  $E(^3\text{He}) = 18.7$  to  $44.1$  MeV [see Table 5.6 in (1974AJ01) and (1979AJ01)]. Resonance-like behavior has been suggested at  $E_x = 16.6, 17.5, 20.0, 20.9$  and  $22.4$  MeV: see (1979AJ01).

Tensor analyzing power measurements are reported for  $E_{\bar{d}} = 0.48$  to  $6.64$  MeV (1980DR01). [See, however, (1980GR14) for a discussion of the (1980DR01) results and for a summary of  $T_{20}(0^\circ)$  for  $E_{\bar{d}} = 0$  to  $40$  MeV.] Measurements of angular distributions and analyzing powers at  $E(^3\text{He}) = 27$  and  $33$  MeV have suggested the presence of a broad resonance(s) at  $E_x \approx 28$  MeV. Vector and tensor analyzing powers have been studied at  $E_{\bar{d}} = 1.0$  to  $13.0$  MeV (1986BI1C, 1986BIZP; prelim.) and  $18, 20$  and  $22$  MeV (1986SA1L; prelim.). See also (1986RO1J) and Tables 5.6 in (1974AJ01) and 5.4 in (1979AJ01).

It is suggested that at low energies [ $E_{\bar{d}} = 2.2$  to  $6$  MeV] reaction (c) goes primarily via a  $J^\pi = \frac{3}{2}^-, T = \frac{1}{2}$  state of  $^5\text{Li}$  located  $0.8 \pm 0.2$  MeV above threshold [i.e.,  $E_x = 18.9 \pm 0.2$  MeV]: see (1979AJ01). Recent studies of the breakup have been reported at  $E_{\bar{d}} = 23.08$  MeV (1986BR1J; reaction (c)) and  $60$  MeV (1985OK03; reaction (d)). For the earlier work see (1984AJ01).

See also (1983MA1E, 1984ALZU, 1984GA1C, 1984HA1J, 1984MU1C, 1984VL1A, 1984WI1C, 1985GU1F, 1985KU1B, 1986BI1E, 1986JA1E, 1986KA1L, 1986LO1B, 1986PO1F, 1986WI1B, 1986WI1E, 1987JO1A, 1987KA1O, 1987TE1D, 1988GU1G, 1988KU1E; applications), (1984YA1A, 1985CA41, 1986DE1K, 1987DO1H, 1987RO25; astrophysics), (1986VA1D, 1987GR08) and (1984DU10, 1984KR1B, 1986AB1C, 1986BL15, 1986ILZZ, 1987AS05; theor.).

### 3. $^3\text{He}(d, d)^3\text{He}$

$$E_b = 16.39$$

In the range  $E_d = 380$  to  $570$  keV, the scattering cross section is consistent with s-wave formation of the  $J^\pi = \frac{3}{2}^+$  state at  $16.66$  MeV. The excitation curves for  $E_d = 1.96$  to  $10.99$  MeV show a broad resonance ( $\Gamma > 1$  MeV) corresponding to  $E_x = 20.0 \pm 0.5$  MeV. From the behavior of the angular distributions an assignment of  $^2\text{D}_{3/2}$  or ( $^2\text{D}, ^4\text{D}_{5/2}$  is favored, if only one state is involved: see (1979AJ01). A phase-shift analysis of the angular distribution and VAP data below  $5$  MeV suggests several MeV broad states [ $^2\text{P}_{3/2}, ^4\text{D}_{7/2}, ^4\text{D}_{5/2}, ^4\text{D}_{3/2}$  and, possibly,  $^4\text{D}_{1/2}$ ]: see (1984AJ01). See also (1987KR18).

Angular distributions and analyzing powers have been measured at many energies to  $E = 44$  MeV: see (1979AJ01, 1984AJ01) for the earlier work, (1982COZO, 1983COZR;  $E_{\bar{d}} = 10$  MeV; TAP; prelim.) and (1987YAZJ;  $E_d = 29.5$  MeV on polarized  $^3\text{He}$ ; prelim.). For d- $^3\text{He}$  correlations see (1987PO03). See also “Complex reactions” in the  $^5\text{Li}$  “GENERAL section”. See also (1987GR08) and (1981PL1A, 1983ZE06, 1983ZE1B, 1985SH08, 1986BO01, 1986KA28, 1986YA1E, 1987ZE1D; theor.).

### 4. $^3\text{He}(t, n)^5\text{Li}$

$$Q_m = 10.13$$

At  $E(^3\text{He}) = 14$  to  $26$  MeV  $^5\text{Li}^*(0, 20.5 \pm 0.8)$  are populated: see (1979AJ01). See also  $^6\text{Li}$ .

5.  ${}^3\text{He}({}^3\text{He}, \text{p}){}^5\text{Li}$

$$Q_m = 10.89$$

The spectrum of protons at  $E({}^3\text{He}) = 3$  to 18 MeV shows a pronounced peak corresponding to  ${}^5\text{Li}_{\text{g.s.}}$  superposed on a continuum: see (1974AJ01). The angular distribution of  $p_0$  has been measured at  $E({}^3\text{He}) = 26$  MeV (1983KI10; polarized target). See also  ${}^6\text{Be}$  and (1986OS1D; theor.).

6.  ${}^4\text{He}(\text{p}, \text{p}){}^4\text{He}$

$$E_b = -1.97$$

Differential cross sections and polarization measurements have been carried out at many energies: see (1966LA04, 1974AJ01, 1979AJ01, 1984AJ01) for the earlier work. Recent measurements are reported at  $E_{\bar{p}} = 65$  MeV (1986FU05;  $A_y$ ), 100 MeV (1983NAZV, 1985GUZX;  $\sigma(\theta)$ ,  $A_y$ ; prelim.) and 495 MeV (1988STZZ; prelim.) and at  $E_p = 695, 793, 890, 991$  MeV (1985VE13;  $\sigma(\theta)$ ) and 1 GeV (1985AL09;  $\sigma(\theta)$ ). Cross sections and  $A_y$  at  $E_{\bar{p}} = 98.7$  and 149.3 MeV for the continuum are reported by (1985WE12).

Phase shifts below  $E_p = 18$  MeV have been determined by (1977DO01) based on all the available cross-section and polarization measurements, using an  $R$ -matrix analysis program. The  $P_{3/2}$  phase shift shows a pronounced resonance corresponding to  ${}^5\text{Li}_{\text{g.s.}}$  while the  $P_{1/2}$  shift changes slowly over a range of several MeV, suggesting that the first excited state is very broad and located 5–10 MeV above the ground state. The reduced widths of the P-wave resonance states are nearly the same. The  $D_{5/2}$ ,  $D_{3/2}$ ,  $F_{7/2}$  and  $F_{5/2}$  phase shifts become greater than  $1^\circ$  at  $E_p \approx 11, 13, 14$  and 16 MeV, respectively (1977DO01). (1986TH1C; prelim.) have measured  $A_y$  for  $1.1 \leq E_{\bar{p}} \leq 2.15$  MeV:  $A_y = 1$  for  $E_p = 1.89$  MeV,  $\theta_{\text{c.m.}} = 87.0^\circ$ .

A phase-shift analysis for  $E_p = 21.8$  to 55 MeV is presented by (1978HO17) [see also analyzing-power contour diagram for  $E_p = 20$  to 65 MeV]. A striking anomaly is seen in the analyzing power at  $E_p = 23$  MeV and the  ${}^2D_{3/2}$  phase shift clearly shows the  $\frac{3}{2}^+$  state at  $E_x = 16.7$  MeV [see also (1979AJ01)]. The other phase shifts  ${}^2S_{1/2}$ ,  ${}^2P_{3/2}$ ,  ${}^2P_{1/2}$ ,  ${}^2D_{5/2}$ ,  ${}^2F_{7/2}$ ,  ${}^2F_{5/2}$ ,  ${}^2G_{9/2}$  and  ${}^2G_{7/2}$  are smooth functions of energy. Both the  ${}^2P_{3/2}$  and  ${}^2P_{1/2}$  inelastic parameters show a somewhat anomalous behavior at  $E_p \approx 30$  MeV; the absorption first increases then decreases to stay rather constant at  $E_p > 40$  MeV. These results are consistent with broad and overlapping states with  $J^\pi = \frac{1}{2}^-$  and  $\frac{3}{2}^-$  at  $E_x \approx 22$  MeV. There is very little splitting of the real parts of the F-wave phase shifts up to 40 MeV. There is some indication (from the  ${}^2G_{7/2}$  phase shifts) of a  $\frac{7}{2}^+$  level around  $E_p = 29$  MeV [ $E_x \approx 21$  MeV]. The G-waves are necessary to fit the detailed shape of the angular distributions for  $E_p = 20$  to 55 MeV (1978HO17). For a contour diagram of the analyzing power for  $E_p = 130$  to 1800 MeV see (1980MO09). For a measurement of the spin rotation parameter,  $R$ , at  $E_{\bar{p}} = 500$  MeV see (1983MO01). See also (1986SA1J; prelim.;  $E_{\bar{p}} = 65$  MeV).

PNC effects have been studied via the elastic scattering of 46 MeV longitudinally polarized protons on  ${}^4\text{He}$ : the longitudinal power  $A_z = -(3.3 \pm 0.9) \times 10^{-7}$ . This was obtained by measuring  $\sigma^+$  and  $\sigma^-$  for the positive and negative helicity of the incident protons (1985LA01, 1986LA29):

the conclusion reached by the authors from this, and all other experiments, is that there does not exist any evidence for a non-zero value of  $f_\pi$ , the weak isovector coupling constant. See also (1984AJ01), (1986ADZT) and (1986HA1Q, 1988NA18; theor.).

Work at very high energies ( $\gg 1$  GeV) is reported by (1982AB1B, 1984GL04, 1984SA39, 1985AB1A, 1985BA1H, 1985GL1B, 1986BE1S, 1987OT1D): see also reaction 7 and (1984AJ01). See also (1987MU1B). For  $\alpha + p$  correlations see (1987PO03) and the “General section” here.

See also (1986GOZY), (1982NA1B, 1983FA1A, 1984FA1B, 1984FR1C, 1984HA1L, 1984HO1H, 1984SI1A, 1985AD1A, 1985AL1D, 1985FA1A, 1985MI10, 1986BA88, 1986ST1D), (1984SP1A; applications), (1984KR1B; muon fusion) and (1981PL1A, 1983AL1C, 1983BI1C, 1983GR20, 1983PA1B, 1983SA38, 1983ZA1A, 1983ZE06, 1983ZE1B, 1984AH03, 1984BL21, 1984CAZW, 1984DE1G, 1984FI20, 1984KW01, 1984LA1B, 1984PR1A, 1984SC1A, 1985BA68, 1985BLZX, 1985DA1A, 1985FL04, 1985HA04, 1985HE1D, 1985HO1B, 1985JA1F, 1985KI11, 1985KO05, 1985KO37, 1985MI1F, 1985NEZW, 1985RO16, 1985SO06, 1985SO08, 1985TE02, 1986AU05, 1986BA2L, 1986BL02, 1986BO01, 1986FR12, 1986GUZZ, 1986KA1G, 1986KA1H, 1986KA35, 1986KO1J, 1986OK06, 1986OR03, 1986SA05, 1986SA30, 1986WA21, 1987DU1B, 1987FO1C, 1987FR1D, 1987FU10, 1987KR16, 1987LI1K, 1987LI1L, 1987PO1G, 1987PR08, 1987QI01, 1987WA11, 1988FR06, 1988HE1C; theor.).

7. (a) ${}^4\text{He}(p, d){}^3\text{He}$	$Q_m = -18.35320$	$E_b = -1.97$
(b) ${}^4\text{He}(p, pn){}^3\text{He}$	$Q_m = -20.57778$	
(c) ${}^4\text{He}(p, 2p){}^3\text{H}$	$Q_m = -19.81403$	
(d) ${}^4\text{He}(p, pd){}^2\text{H}$	$Q_m = -23.84674$	

Angular distributions of deuterons and of  ${}^3\text{He}$  ions (reaction (a)) have been measured for  $E_p = 27.9$  to 770 MeV and at  $E_\alpha = 3.98$  GeV/c [see (1979AJ01, 1984AJ01)] as well as at  $E_{\bar{p}} = 100$  MeV (1983NAZV; prelim.; also  $A_y$ ), 200 and 400 MeV (1986AL01; also  $A_y$ ). Excitation functions are reported at several energies in the range  $E_p = 38.5$  to 44.6 MeV and 200 to 500 MeV. Continuum yields and  $A_y$  have been studied at  $E_{\bar{p}} = 98.7$  and 149.3 MeV by (1985WE12). For polarization measurements to 500 MeV see above and (1979AJ01, 1984AJ01). See also (1988BAZH).

For reactions (b), (c) and (d) see (1974AJ01, 1979AJ01, 1984AJ01). The breakup of  ${}^4\text{He}$  via reaction (c) has recently been studied by (1986FU05): large values of  $A_y$  in the FSI region are reported. For breakup processes at high energies, including pion production, see (1983AN13, 1983MO14, 1984WA1K, 1985BA1H, 1985GL1B, 1986BA2E, 1986BA2M). See also (1983AN18, 1987MUZZ, 1987TEZZ, 1988PA1E), (1983CH1B, 1987MU1B), (1983ZH04, 1984KO1E, 1984LI1B, 1986GO1J, 1987LY1C, 1987MI1N; theor.).

8.  ${}^4\text{He}(\bar{p}, \bar{p}){}^4\text{He}$

Antiproton interactions with  ${}^4\text{He}$  have been studied by (1984BA60, 1985BA76, 1987BA12, 1987BA47, 1987BA69). See also (1984BA74, 1984FA14; astrophysics) and (1983FA16, 1986DO20, 1987NA23; theor.).

9. (a)  ${}^4\text{He}(d, n){}^5\text{Li}$   $Q_m = -4.19$   
 (b)  ${}^4\text{He}(d, np){}^4\text{He}$   $Q_m = -2.22459$

For reaction (a) see reaction 8 in  ${}^5\text{He}$  (1985WI15) and (1987KAZL;  $E_d = 15$  MeV;  $n_0$ ; pre-lim.). Reaction (b) has been studied at  $E_d = 12$  to  $17$  MeV and at  $E_\alpha = 18.0$  to  $140$  MeV: see (1979AJ01, 1984AJ01),  ${}^6\text{Li}$  and (1985DO03, 1987KUZU; theor.).

10. (a)  ${}^4\text{He}({}^3\text{He}, d){}^5\text{Li}$   $Q_m = -7.46$   
 (b)  ${}^4\text{He}({}^3\text{He}, pd){}^4\text{He}$   $Q_m = -5.49354$

At  $E_\alpha = 26.3$  MeV,  ${}^5\text{Li}_{\text{g.s.}}$  is reported to have a width of  $1.9 \pm 0.25$  MeV while the first excited state is suggested to lie at  $E_x = 2.82 \pm 0.35$  MeV,  $\Gamma = 1.64 \pm 0.25$  MeV [reaction (b)]: see (1982NE09, 1986YA01). See also (1985NEZW).

11.  ${}^4\text{He}({}^7\text{Li}, {}^6\text{He}){}^5\text{Li}$   $Q_m = -11.94$

See reaction 9 in  ${}^5\text{He}$  (1988WO10).

12.  ${}^6\text{Li}(\pi^+, p){}^5\text{Li}$   $Q_m = 134.69$

Differential cross sections have been measured at  $E_\pi = 75$  and  $150$  MeV for  $p_0$ : see (1984AJ01).

13. (a)  ${}^6\text{Li}(p, d){}^5\text{Li}$   $Q_m = -3.44$   
 (b)  ${}^6\text{Li}(p, pd){}^4\text{He}$   $Q_m = -1.4750$   
 (c)  ${}^6\text{Li}(p, pn){}^5\text{Li}$   $Q_m = -5.66$

Angular distributions have been measured at  $E_p = 18.6$  to  $185$  MeV. At the highest energy, the spectra are characterized by a broad asymmetric peak corresponding to  ${}^5\text{Li}_{\text{g.s.}}$ , a narrow peak [ ${}^5\text{Li}^*(16.7)$ ] and a broad peak at  $E_x \approx 20$  MeV. DWBA analysis leads to  $C^2S = 0.64$  and  $0.57$  for  ${}^5\text{Li}^*(0, 16.7)$ . The first excited state of  ${}^5\text{Li}$  is also reported to be populated: see (1984AJ01).

Reaction (b) has been studied at  $E_p = 9$  to  $50$  MeV: the  $p$ - $\alpha$  FSI corresponding to  ${}^5\text{Li}_{g.s.}$  is observed [see (1979AJ01)]. See also (1983CA13, 1986NI1B). At  $1$  GeV (reaction (c)) the separation energy between  $4$ – $5$  MeV broad  $1p_{3/2}$  and  $1s_{1/2}$  peaks is reported to be  $17.7 \pm 0.5$  MeV (1985BE30, 1985DO16). See also (1985PA03;  $E_p = 70$  MeV).

14. (a)  ${}^6\text{Li}(d, t){}^5\text{Li}$   $Q_m = 0.59$   
 (b)  ${}^6\text{Li}(d, pt){}^4\text{He}$   $Q_m = 2.5577$

Angular distributions of the  $t_0$  group have been measured at  $E_d = 15$  and  $20$  MeV: see (1974AJ01). Reaction (b) has been studied at  $E_d = 0.12$  to  $10.5$  MeV: see (1984AJ01). See also  ${}^8\text{Be}$ .

15. (a)  ${}^6\text{Li}({}^3\text{He}, \alpha){}^5\text{Li}$   $Q_m = 14.91$   
 (b)  ${}^6\text{Li}({}^3\text{He}, p\alpha){}^4\text{He}$   $Q_m = 16.8782$

At  $E({}^3\text{He}) = 25.5$  MeV,  ${}^5\text{Li}^*(0, 16.7)$  and two broad peaks at  $E_x \approx 19.8$  and  $22.7$  MeV [ $\Gamma_{c.m.} = 2$  and  $1$  MeV] are populated: see (1979AJ01). At  $E({}^3\text{He}) = 33.3$  MeV angular distributions and analyzing powers have been studied for  ${}^5\text{Li}^*(0, 16.7)$  [ $\Gamma \approx 1.6$  and  $\approx 0.4$  MeV]: see (1984AJ01). In reaction (b) the parameters of the first excited state are deduced to be  $E_x = 5.0 \pm 0.7$  MeV,  $\Gamma_{c.m.} = 5.7 \pm 0.7$  MeV (1984AR17;  $E({}^3\text{He}) = 1.7$  and  $2.3$  MeV),  $E_x = 5.8 \pm 0.5$  MeV,  $\Gamma_{c.m.} = 5.2 \pm 0.5$  MeV (1987FA11;  $E({}^3\text{He}) = 1.65$  MeV). Angular distributions of protons from the decay of  ${}^5\text{Li}_{g.s.}$  are reported by (1988BU04;  $E({}^3\text{He}) = 1.5$  to  $3.5$  MeV). See also (1985BA1U, 1987ZA07), (1984AJ01) and  ${}^8\text{Be}$ .

16.  ${}^6\text{Li}({}^6\text{Li}, {}^7\text{Li}){}^5\text{Li}$   $Q_m = 1.58$

Angular distributions have been measured at  $E({}^6\text{Li}) = 156$  MeV to  ${}^5\text{Li}_{g.s.}$ . Unresolved states at  $E_x = 16$ – $20$  MeV are also populated (1987MI34).

17.  ${}^6\text{Li}({}^{13}\text{C}, {}^{14}\text{C}){}^5\text{Li}$   $Q_m = 2.51$

See reaction 9 in  ${}^5\text{He}$  (1988WO10).

18. (a)  ${}^7\text{Li}(p, t){}^5\text{Li}$   $Q_m = -4.43$   
 (b)  ${}^7\text{Li}(p, nd){}^5\text{Li}$   $Q_m = -10.69$

At  $E_p = 43.7$  MeV, a triton group is observed to  ${}^5\text{Li}(0)$  ( $\Gamma = 1.55 \pm 0.15$  MeV): the angular distribution is consistent with a substantial mixing of  $L = 0$  and 2 transfer. There is some evidence also for a very broad excited state between  $E_x = 2$  and 5 MeV.  ${}^5\text{Li}^*(16.7, 20.0)$  were not observed. The formation of  ${}^5\text{Li}^*(16.7)({}^4\text{S}_{3/2})$  would be  $S$ -forbidden: the absence of  ${}^5\text{Li}^*(20.0)$  would indicate that this state(s) is also of quartet character [see reaction 20 in  ${}^5\text{He}$ ]. Weak, broad states at  $E_x = 22.0 \pm 0.5$  MeV and  $25.0 \pm 0.5$  MeV and possibly 34 MeV are reported in a coincidence experiment in which three- and four-particle breakup was analyzed: see (1979AJ01). See also (1988BAZH). For reaction (b) at  $E_p = 670$  MeV see (1984AJ01). See also (1985NEZW; theor.).



A kinematically complete experiment is reported at  $E({}^3\text{He}) = 120$  MeV. The missing mass spectrum shows the ground-state peak and a 4 MeV wide bump at  $E_x \approx 34$  MeV, and some slight indication of a small bump at  $22.0 \pm 0.5$  MeV (1985FR01).



See (1984KO25).



At  $E_\alpha = 90$  MeV differential cross sections have been measured for the transitions to  ${}^5\text{Li}_{\text{g.s.}} + {}^8\text{Li}_{\text{g.s.}}$ : see (1984AJ01).



An angular distribution is reported at  $E_d = 13.6$  MeV (1983DO10). See also (1984SH1E; theor.).



At  $E({}^3\text{He}) = 2.3$  and 5.0 MeV the reaction is reported to proceed via  ${}^9\text{B}^*(4.9)$  to  ${}^5\text{Li}_{\text{g.s.}}$  (1986AR14). See also (1988AR05) and  ${}^9\text{B}$ .

**${}^5\text{Be}$**   
(Fig. 3)

The absence of any group structure in the neutron spectrum in the reaction  ${}^3\text{He}({}^3\text{He}, n){}^5\text{Be}$  at  $E({}^3\text{He}) = 18.0$  to  $26.0$  MeV indicates that  ${}^5\text{Be}(0)$  is at least  $4.2$  MeV unstable with respect to  ${}^3\text{He}+2p$  [ $(M-A) > 33.7$  MeV]. With Coulomb corrections adjusted to match the  $16.7$  MeV states of  ${}^5\text{He}$ – ${}^5\text{Li}$ , this observation places the first  $T = \frac{3}{2}$  level in these nuclei above  $E_x = 21.4$  MeV: see (1979AJ01).

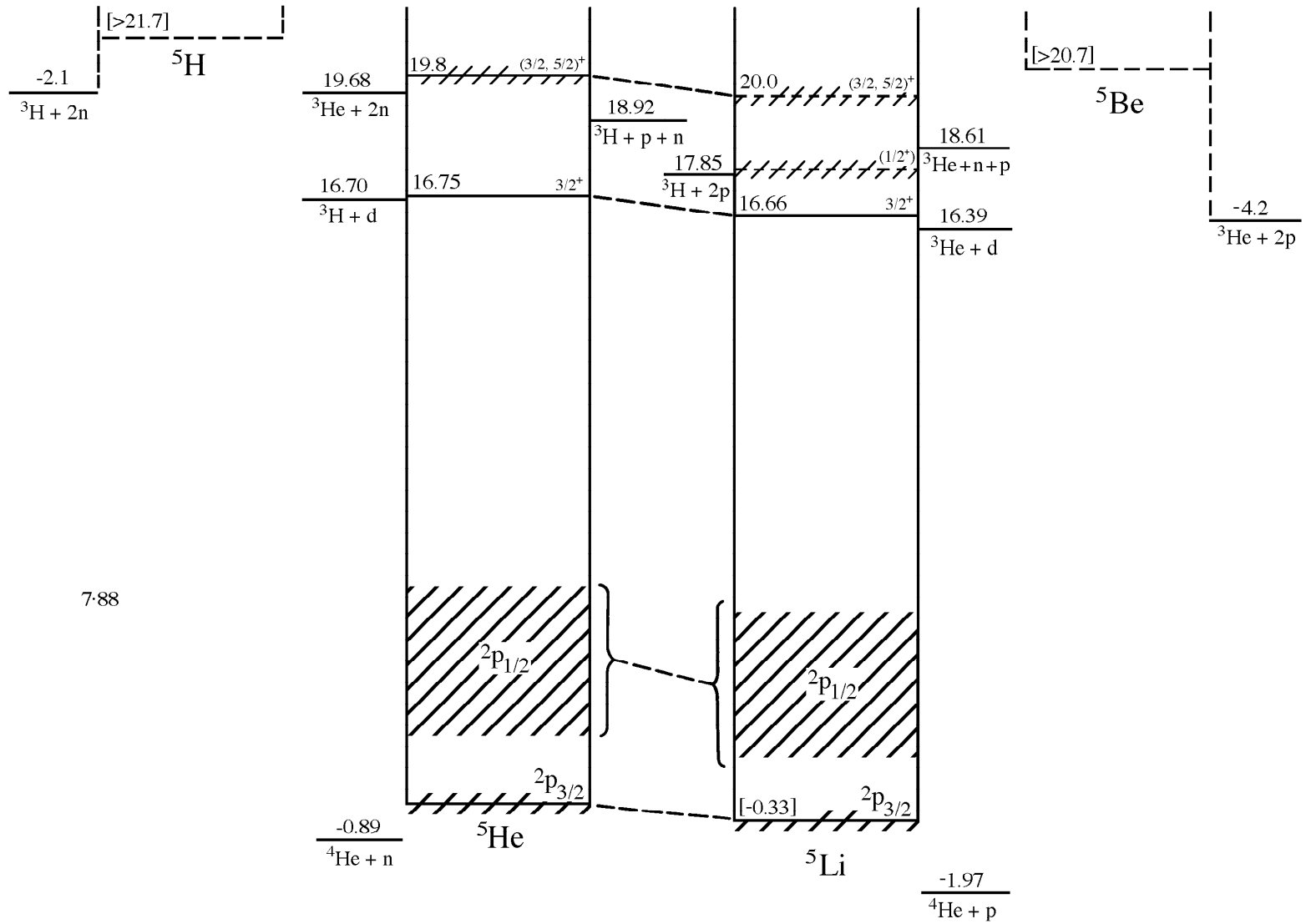

Fig. 3: Isobar diagram,  $A = 5$ . The diagrams for individual isobars have been shifted vertically to eliminate the neutron-proton mass difference and the Coulomb energy, taken as  $E_C = 0.60Z(Z - 1)/A^{1/3}$ . Energies in square brackets represent the (approximate) nuclear energy,  $E_N = M(Z, A) - ZM(\text{H}) - NM(\text{n}) - E_C$ , minus the corresponding quantity for  ${}^5\text{He}$ : here  $M$  represents the atomic mass excess in MeV. Levels which are presumed to be isospin multiplets are connected by dashed lines.



## References

(Closed 1 June 1988)

- 1966HO07 B. Hoop, Jr. and H.H. Barschall, Nucl. Phys. 83 (1966) 65
- 1966LA04 T. Lauritsen and F. Ajzenberg-Selove, Nucl. Phys. 78 (1966) 1
- 1974AJ01 F. Ajzenberg-Selove and T. Lauritsen, Nucl. Phys. A227 (1974) 1
- 1977DO01 D.C. Dodder, G.M. Hale, N. Jarmie, J.H. Jett, P.W. Keaton, Jr., R.A. Nisley and K. Witte, Phys. Rev. C15 (1977) 518
- 1978HO17 A. Houdayer, N.E. Davison, S.A. Elbakt, A.M. Sourkes, W.T.H. van Oers and A.D. Bacher, Phys. Rev. C18 (1978) 1985
- 1979AJ01 F. Ajzenberg-Selove, Nucl. Phys. A320 (1979) 1
- 1980DR01 L.J. Dries, H.W. Clark, R. Detoma, Jr., J.L. Regner and T.R. Donoghue, Phys. Rev. C21 (1980) 475
- 1980GR14 W. Gruebler, P.A. Schmelzbach and V. Konig, Phys. Rev. C22 (1980) 2243
- 1980MO09 G.A. Moss, L.G. Greeniaus, J.M. Cameron, D.A. Hutcheon, R.L. Liljestrand, C.A. Miller, G. Roy, B.K.S. Koene, W.T.H. van Oers, A.W. Stetz et al., Phys. Rev. C21 (1980) 1932
- 1981ER10 J. Ero, Z. Fodor, P. Koncz, Z. Seres, M. Csatos, B.A. Khomenko, N.N. Khovanskij, Z.V. Krumstein, Yu.P. Merekov and V.I. Petrukhin, Nucl. Phys. A372 (1981) 317
- 1981MC09 R.D. McKeown, S.J. Sanders, J.P. Schiffer, H.E. Jackson, M. Paul, J.R. Specht, E.J. Stephenson, R.P. Redwine and R.E. Segel, Phys. Rev. C24 (1981) 211
- 1981PL1A G.R. Plattner, Nukleonika 26 (1981) 1005
- 1982AB1B V.G. Ableev, V.A. Bodyagin, G.G. Vorob'ev, R. Dymazh, S.A. Zaporozhets, V.I. Inozemtsev, A.A. Nomofilov, N.M. Piskunov, I.M. Sitnik, E.A. Stokovskii et al., Yad. Fiz. 36 (1982) 1434; Sov. J. Nucl. Phys. 36 (1982) 834
- 1982AZ02 A.A. Azzam and M.F. Fawzy, Indian J. Phys. A56 (1982) 288
- 1982COZO P.C. Colby and W. Haeberli, Bull. Amer. Phys. Soc. 27 (1982) 700, AE7
- 1982KA1D K. Kar and J.C. Parikh, Pramana 19 (1982) 555
- 1982NA1B Narayan, Proc. VI High Energy Phys. Symp., Mysore, India (1982) 57
- 1982NE09 O.F. Nemets, A.M. Yasnogorodsky, V.V. Ostashko, O.M. Povozhnik and V.N. Unn, Pisma Zh. Eksp. Teor. Fiz. 35 (1982) 537; JETP Lett. 35 (1982) 666
- 1982PO12 V.S. Popov, A.E. Kudryavtsev, V.I. Lisin and V.D. Mur, Pisma Zh. Eksp. Teor. Fiz. 36 (1982) 207; JETP Lett. (USSR) 36 (1982) 257

- 1982SM09 P.F. Smith, J.R.J. Bennett, G.J. Homer, J.D. Lewin, H.E. Walford and W.A. Smith, Nucl. Phys. B206 (1982) 333
- 1983AL1C Alberi, Malecki and Roberto, Lett. Nuovo Cim. 36 (1983) 409
- 1983AN13 L. Anderson, W. Bruckner, E. Moeller, S. Nagamiya, S. Nissen-Meyer, L. Schroeder, G. Shapiro and H. Steiner, Phys. Rev. C28 (1983) 1224; Erratum Phys. Rev. C28 (1983) 1246
- 1983AN18 M.N. Andronenko, E.N. Volnin, A.A. Vorobev, V.T. Grachev, A.A. Lobodenko, I.I. Straskovsky and L.N. Uvarov, Pisma Zh. Eksp. Teor. Fiz. 37 (1983) 446; JETP Lett. 37 (1983) 530
- 1983ANZQ Y. Ando, M. Uno and M. Yamada, JAERI-M-83-025 (1983)
- 1983BA1D Bando, Prog. Theor. Phys. 69 (1983) 1731
- 1983BAZP M.D. Barker, D. Holslin, P.A. Quin and W. Haeberli, Bull. Amer. Phys. Soc. 28 (1983) 987
- 1983BE1G B. Belyaev, M.I. Musakhanov and A.M. Rakhimov, Sov. J. Nucl. Phys. 38 (1983) 196
- 1983BE55 J.J. Bevelacqua, Indian J. Phys. 57A (1983) 26
- 1983BI1C Bizzeti, Riv. Nuovo Cim. 6 (1983) 1
- 1983CA13 G. Calvi, M. Lattuada, F. Riggi, C. Spitaleri, D. Vinciguerra and D. Miljanic, Lett. Nuovo Cim. 37 (1983) 279
- 1983CH1B Chant, AIP Conf. Proc. 97 (1983) 205
- 1983COZR P.C. Colby and W. Haeberli, Bull. Amer. Phys. Soc. 28 (1983) 987, DB3
- 1983DM01 V.F. Dmitriev, V.V. Flambaum, O.P. Sushkov and V.B. Telitsin, Phys. Lett. B125 (1983) 1
- 1983DO10 V.N. Dobrikov, O.F. Nemets, A.S. Gass and A.A. Shvedov, Izv. Akad. Nauk SSSR, Ser. Fiz. 47 (1983) 943
- 1983FA16 I.V. Falomkin, F. Nichitiu and G. Piragino, Lett. Nuovo Cim. 38 (1983) 211
- 1983FA1A M.A. Faessler, Nucl. Phys. A400 (1983) 525
- 1983FE07 V.N. Fetisov, L. Majling, J. Zofka and R.A. Eramzhyan, Z. Phys. A314 (1983) 239
- 1983GO06 O.K. Gorpinich, E.P. Kadkin, S.N. Kondratev, Yu.N. Lobach, M.V. Pasechnik, L.S. Saltykov and V.V. Tokarevsky, Izv. Akad. Nauk SSSR Ser. Fiz. 47 (1983) 185
- 1983GO1C V.I. Golubev, N.G. Makeev, E.S. Pashchenko, N.V. Rubtsov, A.A. Spirin, O.K. Surskii, V.A. Tsukerman and G.N. Cheremukhin, JETP Lett. 37 (1983) 20
- 1983GR20 J.M. Greben and R. Gourishankar, Nucl. Phys. A405 (1983) 445
- 1983HA20 B. Haesner, W. Heeringa, H.O. Klages, H. Dobiash, G. Schmalz, P. Schwarz, J. Wilczynski, B. Zeitnitz and F. Kappeler, Phys. Rev. C28 (1983) 995
- 1983HAYX G.M. Hale, D.C. Dodder and J.C. DeVeaux, in Antwerp 82 (1983) 326

- 1983HU1A Huang, in Florence (1983) 762
- 1983JA09 L. Jarczyk, B. Kamys, Z. Rudy, A. Strzalkowski, H. Witala, M. Hugi, J. Lang, R. Muller, J. Sromicki and H.H. Wolter. Phys. Rev. C28 (1983) 700
- 1983JO1B S.E. Jones, A.N. Anderson, A.J. Caffrey, J.B. Walter, K.D. Watts, J.N. Bradbury, P.A.M. Gram, M. Leon, H.R. Maltrud and M.A. Paciotti, Phys. Rev. Lett. 51 (1983) 1757
- 1983KI10 U. Kirchner, R. Beckmann, U. Holm and H.-G. Korber, Nucl. Phys. A405 (1983) 159
- 1983KU06 V.I. Kukulín, V.N. Pomerantsev, V.G. Emelyanov and V.I. Klimov, Yad. Fiz. 37 (1983) 862; Sov. J. Nucl. Phys. 37 (1983) 514
- 1983MA1E T.L.M. Marcuso, S.J. Rothman, L.J. Nowicki and P. Baldo, Nucl. Instrum. Meth. Phys. Res. 211 (1983) 227
- 1983MO01 G.A. Moss, C.A. Davis, J.M. Greben, L.G. Greeniaus, G. Roy, J. Uegaki, R. Abegg, D.A. Hutcheon, C.A. Miller and W.T.H. Van Oers, Nucl. Phys. A392 (1983) 361
- 1983MO14 E. Moeller, L. Anderson, W. Bruckner, S. Nagamiya, S. Nissen-Meyer, L. Schroeder, G. Shapiro and H. Steiner, Phys. Rev. C28 (1983) 1246
- 1983MO1C T. Motoba, H. Bando and K. Ikeda, Prog. Theor. Phys. 70 (1983) 189
- 1983NAZV A. Nadasen, P.G. Roos, G. Ciangaru, D. Mack, L. Rees, A.A. Cowley, K. Kwiatkowski, P. Schwandt and R.E. Warner, Bull. Amer. Phys. Soc. 28 (1983) 987
- 1983PA1B Parmentola and Feshbach, in Florence (1983) 395
- 1983PO1E Ponomarev, Atomkernenerg. Kerntech. 43 (1983) 175
- 1983SA38 A.N. Safronov, Pisma Zh. Eksp. Teor. Fiz. 37 (1983) 608; JETP Lett. 37 (1983) 727
- 1983SG1A Sguigna and Harms, Atomkernenerg. Kerntech. 43 (1983) 191
- 1983SH1E Shi and Zhuang, Phys. Energ. Fortis Phys. Nucl. 7 (1983) 605
- 1983SH38 Y.-J. Shi, Phys. Rev. C28 (1983) 2452
- 1983SP06 Ts.P. Spasov, Ch.M. Chernev, Yu.A. Batusov and R.A. Eramzhyan, Bulg. J. Phys. 10 (1983) 581
- 1983TA1C Takahashi and Moats, Atomkernenerg. Kerntech. 43 (1983) 188
- 1983VD03 A.I. Vdovin, E.P. Kadkin, I.I. Loshchakov, M.V. Pasechnik and L.S. Saltykov, Izv. Akad. Nauk SSSR, Ser. Fiz. 47 (1983) 2219
- 1983VO02 V.T. Voronchev, V.I. Kukulín, V.M. Krasnopolsky and P.L. Polyakov, Yad. Fiz. 37 (1983) 271; Sov. J. Nucl. Phys. 37 (1983) 161
- 1983ZA1A Zankel, Proc. Int. Conf., Antwerp, Belgium, 1982 (1983) 698
- 1983ZE06 F. Zeng, J. Zhang and X. Zhao, Chin. J. Nucl. Phys. 5 (1983) 51
- 1983ZE1B F. Zeng, J. Zhang and X. Zhao, Chin. Phys. 3 (1983) 975

- 1983ZH04 M.I. Zhurina, A.M. Popova, A.P. Trishchenko and E.K. Shabalina, *Izv. Akad. Nauk SSSR Ser. Fiz.* 47 (1983) 993
- 1984AH03 I. Ahmad and S.K. Singh, *J. Phys. (London)* G10 (1984) L55
- 1984AJ01 F. Ajzenberg-Selove, *Nucl. Phys.* A413 (1984) 1
- 1984ALZU T.K. Alexander, *Bull. Amer. Phys. Soc.* 29 (1984) 1076, R6.3
- 1984AN1A Anderson et al., *Bull. Amer. Phys. Soc.* 29 (1984) 671
- 1984AN1C Anderson, in *Muon-Catalyzed Fusion Workshop, Wyoming* (1984) 68
- 1984AR17 N. Arena, S. Cavallaro, A.S. Figuera, P. D'Agostino, G. Fazio, G. Giardina and F. Mezzanares, *Lett. Nuovo Cim.* 41 (1984) 59
- 1984AS1D F. Asai, H. Bando and M. Sano, *Phys. Lett.* B145 (1984) 19
- 1984BA1D Barit, Kuzmin and Makarov, in *Alma Ata* (1984) 559
- 1984BA1V Balin et al., in *Panic* (1984) L25
- 1984BA60 F. Balestra, Yu.A. Batusov, G. Bendiscioli, M.P. Bussa, L. Busso, I.V. Falomkin, L. Ferrero, V. Filippini, G. Fumagalli, G. Gervino et al., *Phys. Lett.* B149 (1984) 69
- 1984BA74 Yu.A. Batusov and the Dubna-Frascati-Padpva-Pavia-Torino Collaboration, *Lett. Nuovo Cim.* 41 (1984) 223
- 1984BE1B M.A. Bernstein, W.A. Friedman and W.G. Lynch, *Phys. Rev.* C29 (1984) 132
- 1984BL21 L.D. Blokhintsev, A.M. Mukjamedzhanov and A.N. Safronov, *Fiz. Elem. Chastits At. Yad.* 15 (1984) 1296; *Sov. J. Part. Nucl* 15 (1984) 580
- 1984BO1A A.R. Bodmer, Q.N. Usmani and J. Carlson, *Phys. Rev.* C29 (1984) 684
- 1984BO1H L.N. Bogdanova and V.E. Markushin, *Fiz. Elem. Chastits At. Yadra* 15 (1984) 808; *Sov. J. Part. Nucl.* 15 (1984) 361
- 1984BR1G W.H. Breunlich, M. Cargnelli, P. Kammel, J. Marton, P. Pawlek, J. Werner, J. Zmeskal, K.M. Crowe, J. Kurck, A. Janett et al., *Phys. Rev. Lett.* 53 (1984) 1137
- 1984BU1E Bubak et al., in *Muon-Catalyzed Fusion Workshop, Wyoming* (1984) 19
- 1984BY1B V.M. Bystritsky, V.P. Dzhelepov, A. Gula, J. Wozniak and V.G. Zinov, *Acta Phys. Pol.* B15 (1984) 689
- 1984CA1B Caffrey et al., *Bull. Amer. Phys. Soc.* 29 (1984) 671
- 1984CAZW C.I. Calle and R.D. Koshel, *Bull. Amer. Phys. Soc.* 29 (1984) 682, DX7
- 1984CE08 F.E. Cecil and F.J. Wilkinson III, *Phys. Rev. Lett.* 53 (1984) 767
- 1984CH1F Chatterjee, in *Muon-Catalyzed Fusion Workshop, Wyoming* (1984) 98
- 1984CH1G H. Chen, F. Zhuang, X. Shi and X. Jin, *Chin. J. Nucl. Phys.* 6 (1984) 303
- 1984DE1G P.A. Devensky, *Bulg. J. Phys.* 11 (1984) 397

- 1984DE52 F.W.N. de Boer, R. van Dantzig, M. Daum, J. Jansen, P.J.S. Watson, L. Felawka, C. Grab, A. van der Schaaf, T. Kozlowski, J. Martino and A.I. Smirnov, Phys. Rev. Lett. 53 (1984) 423
- 1984DU10 E.I. Dubovoi and Z.F. Kertkoev, Yad. Fiz. 39 (1984) 1140; Sov. J. Nucl. Phys. 39 (1984) 720
- 1984FA14 I.V. Falomkin, G.B. Pontecorvo, M.G. Sapozhnikov, M.Yu. Khlopov, F. Balestra and G. Piragino, Nuovo Cim. A79 (1984) 193
- 1984FA1B M.A. Faessler, Phys. Rept. 115 (1984) 1
- 1984FI1F V.V. Filchenkov, L.N. Somov and V.G. Zinov, Nucl. Instrum. Meth. Phys. Res. A228 (1984) 174
- 1984FI20 G.F. Filippov, V.S. Vasilevskii and A.V. Nesterov, Yad. Fiz. 40 (1984) 1418; Sov. J. Nucl. Phys. 40 (1984) 901
- 1984FR13 H. Friedrich, Phys. Lett. B146 (1984) 135
- 1984FR1C W. Frati, Nucl. Phys. A418 (1984) 177
- 1984GA1C J. Galambos, J. Gilligan, E. Greenspan, P. Stroud and G.H. Miley, Nucl. Fusion 24 (1984) 739
- 1984GL04 V.V. Glagolev, R.M. Lebedev, L.I. Zhuravleva, M. Bano, M. Seman, L. Sandor, J. Hlavacova, G. Martinska, J. Patocka, J. Urban et al., Z. Phys. A317 (1984) 335
- 1984GL1C Glaudemans, in Drexel Univ. Symp. (1984)
- 1984HA1J Harms, in Muon-Catalyzed Fusion Workshop, Wyoming (1984) 142
- 1984HA1L W. Haeberli, AIP Conf. Proc. 123 (1984) 337
- 1984HO01 B. Hoistad, M. Gazzaly, B. Aas, G. Igo, A. Rahbar, C. Whitten, G.S. Adams and R. Whitney, Phys. Rev. C29 (1984) 553
- 1984HO1H B.R. Holstein, AIP Conf. Proc. 123 (1984) 1110
- 1984HU04 H.A. Hussain, Int. J. Appl. Radiat. Isotop. 35 (1984) 201
- 1984HU1B E.V. Hungerford and L.C. Biedenham, Phys. Lett. B142 (1984) 232
- 1984JA08 N. Jarmie, R.E. Brown and R.A. Hardekopf, Phys. Rev. C29 (1984) 2031; Erratum Phys. Rev. C33 (1986) 385
- 1984KL05 H.O. Klages, H. Dobiasch, P. Doll, H. Krupp, M. Oexner, P. Plischke, B. Zeitnitz, F.P. Brady and J.C. Hiebert, Nucl. Instrum. Meth. Phys. Res. A219 (1984) 269
- 1984KO1E Komarov, Muller and Tesch, in Panic (1984) 120
- 1984KO1F Kobayashi and Ikeda, in Panic (1984) M1
- 1984KO25 I. Koenig, D. Fick, S. Kossionides, P. Egelhof, K.-H. Mobius and E. Steffens, Z. Phys. A318 (1984) 135

- 1984KR1B A.V. Kravtsov, N.P. Popov and G.E. Solvakin, *Pisma Zh. Eksp. Teor. Fiz.* 40 (1984) 124; *JETP Lett. (USSR)* 40 (1984) 875
- 1984KR23 H. Krupp, J.C. Hiebert, H.O. Klages, P. Doll, J. Hansmeyer, P. Plischke, J. Wilczynski and H. Zankel, *Phys. Rev. C* 30 (1984) 1810
- 1984KW01 N.H. Kwong and J. Hufner, *Phys. Lett.* B146 (1984) 370
- 1984LA1B Landau, Sagen and Paez, in *Panic* (1984) I32
- 1984LI1B Lievshin and Fursa, in *Alma Ata* (1984) 488
- 1984MA71 H. Ma, C. Rong, J. Zheng, J. Liu, S. Zhang and P. Ren, *Chin. J. Nucl. Phys.* 6 (1984) 219
- 1984ME1B L.I. Men'shikov and L.I. Ponomarev, *JEPT Lett.* 39 (1984) 663
- 1984MI1E D.J. Millener, *AIP Conf. Proc.* 123 (1984) 850
- 1984MO1G D.L., Jr. Morgan, in *Muon-Catalyzed Fusion Workshop. Wyoming* (1984) 109
- 1984MU1C Murphy and Strachan, *Bull. Amer. Phys. Soc.* 29 (1984) 1333
- 1984NE1B Newman, Fisher and Thomas, *Bull. Amer. Phys. Soc.* 29 (1984) 1309
- 1984OT1A Ottewitte, in *Muon-Catalyzed Fusion Workshop. Wyoming* (1984) 158
- 1984PO11 D.N. Poenaru and M. Ivascu, *J. Phys.* 45 (1984) 1099
- 1984PR1A J. Proriol, *Nuovo Cim.* A83 (1984) 50
- 1984SA39 L. Satta, J. Dufflo, F. Plouin, P. Picozza, L. Goldzahl, J. Banaigs, R. Frascaria, F.L. Fabbri, A. Codino, J. Berge et al., *Phys. Lett.* B139 (1984) 263
- 1984SC1A E.W. Schmid, *Nucl. Phys.* A416 (1984) 347
- 1984SH07 S. Shinmura, Y. Akaishi and H. Tanaka, *Prog. Theor. Phys. (Kyoto)* 71 (1984) 546
- 1984SH1E Shvedov, Dobrikov and Nemets, in *Alma Ata* (1984) 332
- 1984SH1F Shvedov, Dobrikov and Nemets, in *Alma Ata* (1984) 333
- 1984SH1J M. Shoeb and M.Z. Khan, *J. Phys.* G10 (1984) 1047
- 1984SHZK P.N. Shen, Y.C. Tang, Y. Fujiwara and H. Kanada, *Bull. Amer. Phys. Soc.* 29 (1984) 701, *EJ* 12
- 1984SI1A J.E. Simmons, *Nucl. Phys.* A416 (1984) 553
- 1984SLZZ I. Slaus, J.M. Lambert, P.A. Treado, T.A. Treado, F.D. Correll, R.E. Brown and N. Jarmie, *Bull. Amer. Phys. Soc.* 29 (1984) 701
- 1984SP1A Spencer and Ludwig, *Bull. Amer. Phys. Soc.* 29 (1984) 1502
- 1984SU1A Sur and Boyd, *Private Communication* (1984)
- 1984VA06 A.G.M. van Hees and P.W.M. Glaudemans, *Z. Phys.* A315 (1984) 223
- 1984VAZS V.S. Vasilevsky, S.P. Kruchinin, G.F. Filippov and L.L. Chopovsky, in *Alma Ata* (1984) 463

- 1984VL1A G. Vlad, *Nuovo Cim.* B84 (1984) 141
- 1984WA1K Warsaw Collaboration, *Yad. Fiz.* 40 (1984) 482; *Sov. J. Nucl. Phys.* 40 (1984) 306
- 1984WI1C Wilson et al., *Bull. Amer. Phys. Soc.* 29 (1984) 1130
- 1984YA1A J. Yang, M.S. Turner, G. Steigman, D.N. Schramm and K.A. Olive, *Astrophys. J.* 281 (1984) 493
- 1984ZH1B F. Zhuang, H.-Z. Chen and X.-N. Jin, *Phys. Energ. Fortis Phys. Nucl.* 8 (1984) 215
- 1984ZW1A Zwarts, Unpublished Ph.D. Thesis, Utrecht (1984)
- 1985AB1A Ableev et al., *Acta Phys. Pol.* B16 (1985) 913
- 1985AD1A Adelberger and Haxton, *Ann. Rev. Nucl. Part. Sci.* 35 (1985) 501
- 1985AH1A I. Ahmad, M. Mian and M.Z. Rahman Khan, *Phys. Rev.* C31 (1985) 1590
- 1985AL09 G.D. Alkhozov, S.L. Belostotsky, Yu.V. Dotsenko, O.A. Domchenkov, N.P. Kuropatkin and V.N. Nikulin, *Yad. Fiz.* 41 (1985) 561; *Sov. J. Nucl. Phys.* 41 (1985) 357
- 1985AL1D S. Ali, A.A.Z. Ahmad and N. Ferdous, *Rev. Mod. Phys.* 57 (1985) 923
- 1985AN28 M.S. Antony, J. Britz, J.B. Bueb and A. Pape, *At. Data Nucl. Data Tables* 33 (1985) 447
- 1985BA1F H. Bando, *Suppl. Prog. Theor. Phys.* 81 (1985) 181
- 1985BA1G D.D. Bakalov, V.S. Melezhik, L.I. Menshikov and S.I. Vinitzky, *Phys. Lett.* B161 (1985) 5
- 1985BA1H J. Banaigs, J. Berger, A. Codino, J. Duflo, L. Goldzahl, F. Plouin, M. De Sanctis, F.L. Fabbri, P. Picozza, L. Satta et al., *Nucl. Phys.* A445 (1985) 737
- 1985BA1U Barna et al., Rept. INFN/BE-85/3 (1985)
- 1985BA68 F.C. Barker and C.L. Woods, *Aust. J. Phys.* 38 (1985) 563
- 1985BA76 F. Balestra, S. Bossolasco, M.P. Bussa, L. Ferrero, D. Panzieri, G. Piragino, F. Tosello, C. Guaraldo, A. Maggiora, Yu.A. Batusov et al., *Phys. Lett.* B165 (1985) 265
- 1985BE1C Berdnikov et al., in *Leningrad* (1985) 302
- 1985BE30 S.L. Belostotsky, S.S. Volkov, A.A. Vorobyev, Yu.V. Dotsenko, L.G. Kudin, N.P. Kuropatkin, O.V. Miklukho, V.N. Nikulin and O.E. Prokofyev, *Yad. Fiz.* 41 (1985) 1425; *Sov. J. Nucl. Phys.* 41 (1985) 903
- 1985BLZX E. Bleszynski, M. Bleszynski and T. Jaroszewicz, *Bull. Amer. Phys. Soc.* 30 (1985) 1281, EC4
- 1985BO1E R.N. Boyd, R.E. Turner, B. Sur, L. Rybarcyk and C. Joseph, *AIP Conf. Proc.* 126 (1985) 145
- 1985BO1J A.S. Botvina, A.S. Il'inov and I.N. Mishustin, *Yad. Fiz.* 42 (1985) 1127; *Sov. J. Nucl. Phys.* 42 (1985) 712

- 1985CA41 G.R. Caughlan, W. A. Fowler, M.J. Harris and B.A. Zimmerman, *At. Data Nucl. Data Tables* 32 (1985) 197
- 1985CE13 F.E. Cecil, D.M. Cole, R. Philbin, N. Jarmie and R.E. Brown, *Phys. Rev. C* 32 (1985) 690
- 1985CE16 F.E. Cecil, D.M. Cole, F.J. Wilkinson III and S.S. Medley, *Nucl. Instrum. Meth. Phys. Res. B* 10-11 (1985) 411
- 1985CO1C J.S. Cohen and M. Leon, *Phys. Rev. Lett.* 55 (1985) 52
- 1985DA1A L.G. Dakhno and N.N. Nikolaev, *Nucl. Phys. A* 436 (1985) 653
- 1985DE17 E. Descroix, M. Bedjidian, J.Y. Grossiord, A. Guichard, M. Gusakov, M. Jacquin, J.R. Pizzi and G. Bagieu, *Nucl. Phys. A* 438 (1985) 112
- 1985DO03 P. Doleschall, Gy. Bencze, M. Bruno, F. Cannata and M. D'Agostino, *Phys. Lett. B* 152 (1985) 1
- 1985DO16 Yu.V. Dotsenko and V.E. Starodubsky, *Yad. Fiz.* 42 (1985) 107; *Sov. J. Nucl. Phys.* 42 (1985) 66
- 1985FA01 Fan Wang and C.W. Wong, *Nucl. Phys. A* 432 (1985) 619
- 1985FA1A M.A. Faessler, *Nucl. Phys. A* 434 (1985) 563
- 1985FI1E G.F. Filippov, V.S. Vasilevskii and L.L. Chopovskii, *Fiz. Elem. Chastits At. Yadra* 16 (1985) 349; *Sov. J. Part. Nucl.* 16 (1985) 153
- 1985FI1G First Research Group, First Research Div., *Phys. Energ. Fortis Phys. Nucl.* 9 (1985) 723
- 1985FIZW R.W. Finlay, in *AIP Conf. Proc.* 124 (1985) 274
- 1985FL04 V.V. Flambaum, V.B. Telitsin and O.B. Sushkov, *Nucl. Phys. A* 444 (1985) 611
- 1985FR01 R. Franke, K. Kochskamper, B. Steinheuer, K. Wingender, W. Von Witsch and H. Machner, *Nucl. Phys. A* 433 (1985) 351
- 1985FR1D A.M. Frolov and V.D. Efros, *J. Phys. B* 18 (1985) L265
- 1985GE06 J.-F. Germond and C. Wilkin, *J. Phys. G* 11 (1985) 1131
- 1985GI1E B.F. Gibson, *AIP Conf. Proc.* 133 (1985) 390
- 1985GL1B V.V. Glagolev, R.M. Lebedev, M. Bano, M. Seman, L. Sandor, J. Hlavacova, G. Martinska, J. Patocka, J. Urban, V.V. Gladun et al.; Dubna-Kosice-Moscow-Strasbourg-Tbilisi-Warsaw Collaboration, *Nucl. Phys. A* 445 (1985) 572
- 1985GO1E A.D. Gocheva, V.V. Gusev, V.S. Melezhhik, L.I. Ponomarev, I.V. Puzynin, T.P. Puzynina, L.N. Somov and S.I. Vinitzky, *Phys. Lett. B* 153 (1985) 349
- 1985GU1F Gusinskii et al., in *Leningrad* (1985) 493
- 1985GU1G A. Gula, *Acta Phys. Pol.* B16 (1985) 589



- 1985GUZX G. Gunderson, S. Villanueva, A. Judd, A. Nadasen, P.G. Roos, D. Mack, F. Khazaie, J. Templon, K. Kwiatkowski, P. Schwandt et al., *Bull. Amer. Phys. Soc.* 30 (1985) 1268
- 1985HA04 K. Hahn, E.W. Schmid and P. Doleschall, *Phys. Rev.* C31 (1985) 325
- 1985HE1D G.-Z. He and C.-H. Cai, *Chin. Phys.* 5 (1985) 699
- 1985HI1A Hinrichsen, Kauffmann and Rafelski, *Bull. Amer. Phys. Soc.* 30 (1985) 793
- 1985HO1B H. Horiuchi, *Prog. Theor. Phys.* 74 (1985) 66
- 1985HOZU D. Holslin, J. Sromicki and W. Haeberli, *Bull. Amer. Phys. Soc.* 30 (1985) 1267
- 1985IK1A K. Ikeda, H. Bando and T. Motoba, *Suppl. Prog. Theor. Phys.* 81 (1985) 147
- 1985JA1F B. Jargeaix and J. Proriol, *Nuovo Cim.* A88 (1985) 87
- 1985KA1C Kauffmann, Muller and Rafelski, *Bull. Amer. Phys. Soc.* 30 (1985) 793
- 1985KA1N P. Kammel, *Lett. Nuovo Cim.* 43 (1985) 349
- 1985KI11 R. Kircher, H. Kamada and S. Oryu, *Prog. Theor. Phys. (Kyoto)* 73 (1985) 1442
- 1985KO05 A.M. Kobos, E.D. Cooper, J.R. Rook and W. Haider, *Nucl. Phys.* A435 (1985) 677
- 1985KO1G Kolesnikov, Zakharov, Kopilov and Tarasov, in *Leningrad* (1985) 199
- 1985KO37 A.M. Kobos, E.D. Cooper, J.I. Johansson and H.S. Sherif, *Nucl. Phys.* A445 (1985) 605
- 1985KU1A Y. Kurihara, Y. Akaishi and H. Tanaka, *Phys. Rev.* C31 (1985) 971
- 1985KU1B K. Kudo, T. Michikawa and T. Kinoshita, *Nucl. Instrum. Meth. Phys. Res.* B12 (1985) 135
- 1985KW02 E. Kwasniewicz and L. Jarczyk, *Nucl. Phys.* A441 (1985) 77
- 1985LA01 J. Lang, Th. Maier, R. Muller, F. Nessi-Tedaldi, Th. Roser, M. Simonius, J. Sromicki and W. Haeberli, *Phys. Rev. Lett.* 54 (1985) 170; Erratum *Phys. Rev. Lett.* 54 (1985) 2729
- 1985LE19 Y. Le Bornec, L. Bimbot, M.P. Combes-Comets, J.C. Jourdain, F. Reide, A. Willis and N. Willis, *J. Phys.* G11 (1985) 1125
- 1985LU08 R.C. Luhn, S. Sen, N.O. Gaiser, S.E. Darden and Y. Koike, *Phys. Rev.* C32 (1985) 11
- 1985ME1C L.I. Men'shikov and L.I. Ponomarev, *JETP Lett.* 41 (1985) 623
- 1985ME1D L.I. Men'shikov, *Yad. Fiz.* 42 (1985) 1449; *Sov. J. Nucl. Phys.* 42 (1985) 918
- 1985MI10 R.E. Mischke, *Nucl. Phys.* A434 (1985) 505c
- 1985MI1F K. Miyagawa, Y. Koike, T. Ueda, T. Sawada and S. Takagi, *Prog. Theor. Phys.* 74 (1985) 1264
- 1985MO1F T. Motoba, H. Bando, K. Ikeda and T. Yamada, *Suppl. Prog. Theor. Phys.* 81 (1985) 42

- 1985NEZW O.F. Nemets, V.V. Ostashko and A.M. Yasnogorodsky, in Leningrad (1985) 320
- 1985OK03 A. Okihana, Nucl. Phys. A443 (1985) 435
- 1985OS02 H. Oswald, M. Buballa, J. Helten, M. Karus, B. Laumann, R. Melzer, P. Niessen, G. Rauprich, J. Schulte-Uebbing, H. Paetz gen. Schieck and Y. Koike, Nucl. Phys. A435 (1985) 77
- 1985OS1C E. Oset and L.L. Salcedo, Nucl. Phys. A443 (1985) 704
- 1985PA03 M.V. Pasechnik, L.S. Saltykov, E.P. Kadkin, I.I. Loshchakov and A.I. Vdovin, Izv. Akad. Nauk SSSR Ser. Fiz. 49 (1985) 53; Bull. Acad. Sci. USSR Phys. Ser. 49 (1985) 55
- 1985PO10 N.A.F.M. Poppelier, L.D. Wood and P.W.M. Glaudemans, Phys. Lett. B157 (1985) 120
- 1985PO11 D.N. Poenaru, M. Ivascu, A. Sandulescu and W. Greiner, Phys. Rev. C32 (1985) 572
- 1985PO18 J. Pochodzalla, W.A. Friedman, C.K. Gelbke, W.G. Lynch, M. Maier, D. Ardouin, H. Delagrange, H. Doubre, C. Gregoire, A. Kyanowski et al., Phys. Lett. B161 (1985) 256
- 1985PO19 J. Pochodzalla, W.A. Friedman, C.K. Gelbke, W.G. Lynch, M. Maier, D. Ardouin, H. Delagrange, H. Doubre, C. Gregoire, A. Kyanowski et al., Phys. Lett. B161 (1985) 275
- 1985RA1B J. Rafelski and B. Muller, Phys. Lett. B164 (1985) 223
- 1985RIZZ J.C. Riley, R.M. Whitton, H.R. Weller and D.R. Tilley, Bull. Amer. Phys. Soc. 30 (1985) 700, AE3
- 1985RO16 T. Roser and M. Simonius, Nucl. Phys. A442 (1985) 701
- 1985SH08 P.N. Shen, Y.C. Tang, Y. Fujiwara and H. Kanada, Phys. Rev. C31 (1985) 2001
- 1985SI1B I. Sick, Helv. Phys. Acta 58 (1985) 746
- 1985SO06 S.A. Sofianos, H. Fiedeldey, L.J. Allen and R. Lipperheide, Phys. Rev. C31 (1985) 2300
- 1985SO08 S.A. Sofianos and H. Fiedeldey, Nucl. Phys. A441 (1985) 573
- 1985SP05 G. Spitz, H. Klar and E.W. Schmid, Z. Phys. A322 (1985) 49
- 1985TA1E K. Takeuchi, H. Takaki and H. Bando, Prog. Theor. Phys. 73 (1985) 841
- 1985TA1F Tanihata et al., Bull. Amer. Phys. Soc. 30 (1985) 1263
- 1985TE02 Y. Terrien and F. Wellers, J. Phys. (Paris) 46 (1985) 1873
- 1985TI07 Y. Tian, Y. Han, Q. Shen, Y. Zhuo, W. Liu, D. Guo and F. Li, Chin. J. Nucl. Phys. 7 (1985) 154
- 1985TI08 Y. Tian, Y. Han, Q. Shen, Y. Zhuo, W. Liu, D. Guo and F. Li, Chin. J. Nucl. Phys. 7 (1985) 344

- 1985VA1B C.DeW Van Siclen, J. Phys. G11 (1985) 267
- 1985VD03 A.I. Vdovin, A.V. Golovin and I.I. Loshchakov, Yad. Fiz. 42 (1985) 134; Sov. J. Nucl. Phys. 42 (1985) 84
- 1985VE13 G.N. Velichko, A.A. Vorobyov, A.V. Dobrovolsky, G.A. Korolev, S.I. Manayenkov, J. Saudinos and A.V. Khanzadeev, Yad. Fiz. 42 (1985) 1325; Sov. J. Nucl. Phys. 42 (1985) 837
- 1985WA13 C.W. Wang, P.G. Roos, N.S. Chant, G. Ciangaru, F. Khazaie, D.J. Mack, A. Nadasen, S.J. Mills, R.E. Warner, E. Norbeck et al., Phys. Rev. C31 (1985) 1662
- 1985WE12 J.S. Wesick, P.G. Roos, N.S. Chant, C.C. Chang, A. Nadasen, L. Rees, N.R. Yoder, A.A. Cowley, S.J. Mills and W.W. Jacobs, Phys. Rev. C32 (1985) 1474
- 1985WI15 K. Wick, U. Berghaus, H. Bruckmann, P. Lara, W. Schutte, B. Anders and Y. Koike, Nucl. Phys. A444 (1985) 49
- 1985WI1A Wieman et al., Bull. Amer. Phys. Soc. 30 (1985) 767
- 1985WI1B D. Wilkinson, Nucl. Phys. A434 (1985) 573
- 1985YA05 T. Yamada, K. Ikeda, H. Bando and T. Motoba, Prog. Theor. Phys. 73 (1985) 397
- 1985YA1B Y. Yamamoto and H. Bando, Prog. Theor. Phys. 73 (1985) 905
- 1986AB1C Abu-Kamar et al., in Harrogate (1985) C85
- 1986ADZT E.G. Adelberger, AIP Conf. Proc. 150 (1986) 1177
- 1986AL01 P.W.F. Alons, J.J. Kraushaar, J.R. Shepard, J.M. Cameron, D.A. Hutcheon, R.P. Liljestrang, W.J. McDonald, C.A. Miller, W.C. Olsen, J.R. Tinsley et al., Phys. Rev. C33 (1986) 406
- 1986AL1H Al-Kusayer, Sahin and Raof, in Santa Fe (1985) 159
- 1986AN1R H.H. Ansari, M. Shoeb and M.Z.R. Rahman Khan, J. Phys. G12 (1986) 1369
- 1986AR14 N. Arena, Seb. Cavallaro, G. Fazio, G. Giardina, A. Italiano and F. Mezzanares, Phys. Rev. Lett. 57 (1986) 1839
- 1986AU05 J.P. Auger, A. Tellez-Arenas, C. Lazard and R.J. Lombard, J. Phys. (London) G12 (1986) 317
- 1986BA1H H. Bando, Czech. J. Phys. B36 (1986) 915
- 1986BA1W H. Bando, Nucl. Phys. A450 (1986) 217c
- 1986BA1Y H.H. Barschall and L. Brown, Found. Phys. 16 (1986) 115
- 1986BA2D R. Babinet, Ann. Physique 11 (1986) 113
- 1986BA2E M. Bano, V. Glagolev, A. Kacharava, M. Kravcikova, R. Lebedev, M. Nioradze, G. Pestova, T. Rogava, Z. Salukvadze, L. Sandor et al., Phys. Lett. B166 (1986) 453
- 1986BA2L M. Bano, J. Hlavacova, M. Kravcikova, G. Martinska, J. Patocka, E. Rusnakova, L. Sandor and J. Urban, Acta Phys. Slovaca 36 (1986) 305

- 1986BA2M M. Bano, H. Braun, J.P. Gerber, V.V. Glagolev, J. Hlavacova, P. Juillot, A.K. Kacharava, K.U. Khairtudinov, R.M. Lebedev, G. Martinska et al., *Acta Phys. Slovaca* 36 (1986) 227
- 1986BA73 A.G. Baryshnikov, L.D. Blokhintsev, R. Kapote and D.A. Savin, *Izv. Akad. Nauk SSSR, Ser. Fiz.* 50 (1986) 1962; *Bull. Acad. Sci. USSR, Phys. Ser.* 50 (1986) 90
- 1986BA88 W. Bauhoff, *At. Data Nucl. Data Tables* 35 (1986) 429
- 1986BE1S W. Bell, K. Braune, G. Claesson, D. Drijard, M.A. Faessler, H.G. Fischer, H. Frehse, R.W. Frey, S. Garpman, W. Geist et al., *Z. Phys.* C30 (1986) 513
- 1986BE35 A.V. Belozyorov, C. Borcea, Z. Dlouhy, A.M. Kalinin, R. Kalpakchieva, Nguyen Hoai Chau, Yu.Ts. Oganessian and Yu.E. Penionzhkevich, *Nucl. Phys.* A460 (1986) 352
- 1986BE44 A.V. Belozorov, K. Borcha, Z. Dlouhy, A.M. Kalinin, Nguen Khoai Tyau and Yu.E. Penionzhkevich, *Izv. Akad. Nauk SSSR Ser. Fiz.* 50 (1986) 1936; *Bull. Acad. Sci USSR Phys. Ser.* 50 (1986) 64
- 1986BI1C M. Bittcher, V. Konig, P.A. Schmelzbach, C. Forstner, W. Gruebler, B. Vuaridel, D. Singy and J. Ulbricht, *J. Phys. Soc. Jpn. Suppl.* 55 (1986) 906
- 1986BI1E M. Bittcher, A. Chisholm, K. Elsener, C. Forstner, W. Gruebler, V. Konig, P.A. Schmelzbach, D. Singy, I. Slaus, F. Sperisen et al., *J. Phys. Soc. Jpn. Suppl.* 55 (1986) 1108
- 1986BIZP M. Bittcher, V. Konig, P.A. Schmelzbach, Ch. Forstner, W. Gruebler, B. Vuaridel, D. Singy and J. Ulbricht, in *Harrogate* (1986) 333; C146
- 1986BL02 E. Bleszynski, M. Bleszynski and T. Jaroszewicz, *Phys. Rev.* C33 (1986) 1228
- 1986BL15 L.D. Blokhintsev, S.M. Rasulev and R. Yarmukhamedov, *Yad. Fiz.* 44 (1986) 1167; *Sov. J. Nucl. Phys.* 44 (1986) 758
- 1986BL1D Blokhintsev, Razikov, Ubaidullaeva and Yarmukhamedov, in *Kharkov* (1986) 449
- 1986BO01 D.H. Boal and J.C. Shillcock, *Phys. Rev.* C33 (1986) 549
- 1986BO1E A.R. Bodmer and Q.N. Usmani, *Nucl. Phys.* A450 (1986) 257c
- 1986BO1F L.N. Bogdanova, L. Bracci, G. Fiorentini, S.S. Gerstein, V.E. Markushin, V.S. Melezhik, L.I. Menshikov and L.I. Ponomarev, *Nucl. Phys.* A454 (1986) 653
- 1986BOZG I.M. Bondarenko and E.E. Petrov, *INDC(CCP)-265/L* (1986)
- 1986BR1H Bradbury, *Bull. Amer. Phys. Soc.* 31 (1986) 849
- 1986BR1J M. Bruno, F. Cannata, M. D'Agostino, M.L. Fiandri, M. Frisoni and M. Lombardi, *Few-Body Syst.* 1 (1986) 63
- 1986BR20 R.E. Brown and N. Jarmie, *Radiat. Eff.* 92 (1986) 45; in *Santa Fe* 85 (1986) 45
- 1986BU1D S. Burzynski and R. Henneck, *J. Phys. Soc. Jpn. Suppl.* 55 (1986) 888
- 1986CA1E M. Caterini, D.A. Thompson, P.T. Wan and J.A. Sawicki, *Nucl. Instrum. Meth. Phys. Res.* B15 (1986) 535

- 1986CA1K J. Carlson, K.E. Schmidt and M.H. Kalos, Proc. 9th Int. Wksp., San Francisco, 1985 (1986) 79
- 1986CE04 C. Cernigoi, N. Grion, G. Pauli, R. Rui and R. Cherubini, Nucl. Phys. A456 (1986) 599
- 1986CH10 C.B. Chitwood, C.K. Gelbke, J. Pochodzalla, Z. Chen, D.J. Fields, W.G. Lynch, R. Morse, M.B. Tsang, D.H. Boal and J.C. Shillcock, Phys. Lett. B172 (1986) 27
- 1986CH1I R.E. Chrien, AIP Conf. Proc. 150 (1986) 325
- 1986CO1J H.E. Conzett and C. Rioux, J. Phys. Soc. Jpn. Suppl. 55 (1986) 908
- 1986CO1K J.S. Cohen and M. Leon, Phys. Rev. A33 (1986) 1437
- 1986CS1A L.P. Csernai and J.I. Kapusta, Phys. Rept. 131 (1986) 223
- 1986DA1B D.H. Davis and J. Pniewski, Contemp. Phys. 27 (1986) 91
- 1986DA1D M. Danos, B. Muller and J. Rafelski, Phys. Rev. A34 (1986) 3642
- 1986DE1K D.S.P. Dearborn, D.N. Schramm and G. Steigman, Astrophys. J. 302 (1986) 35
- 1986DO1B Dover, Proc. Int. Nucl. Phys. Conf., Harrogate, U.K., No. 68, Vol. 2 (1986) 99
- 1986DO1H Doll et al., in Harrogate (1986) H6
- 1986DO20 C.B. Dover, Czech. J. Phys. B36 (1986) 329
- 1986EN1A Engelmann and Bardy, Rept. CEA-R-5340 (1986)
- 1986FR12 V. Franco and Y. Yin, Phys. Rev. C34 (1986) 608
- 1986FU05 K. Fukunaga, S. Kakigi, T. Ohsawa, A. Okihana, T. Sekioka, H. Nakamura-Yokota and S. Tanaka, Nucl. Phys. A456 (1986) 48
- 1986GO1J R.J. Gould, Nucl. Phys. B266 (1986) 737
- 1986GOZY M. Gordon, R.L. McGrath, P. DeYoung, J. Alexander, X. Lu and D.M. De Castro-Rizzo, Bull. Amer. Phys. Soc. 31 (1986) 784, BH1
- 1986GR1H G. Grosshög, D. Aronsson, K.-H. Beimer, R. Rydz, N.G. Sjostrand, L.O. Pekkari and O. Skeppstedt, Nucl. Instrum. Meth. Phys. Res. A249 (1986) 468
- 1986GUZZ G. Gunderson, S. Lenk, A. Nadasen, P. Schwandt, P.G. Roos, D. Mack, R.E. Warner, A.A. Cowley and J. Lawrie, Bull. Amer. Phys. Soc. 31 (1986) 821, EL2
- 1986HA1N W. Haeberli and T. Wise, J. Phys. Soc. Jpn. Suppl. 55 (1986) 483
- 1986HA1Q Haxton, Proc. Int. Nucl. Phys. Conf., Harrogate, U.K., No. 68, Vol. 2 (1986) 415
- 1986HA1V Haldy, Kumar, Leo and Green, in Santa Fe (1985) 235
- 1986HO1E D. Holslin, J. Sromicki and W. Haeberli, J. Phys. Soc. Jpn. Suppl. 55 (1986) 904
- 1986HU1C C.-Y. Hu, Phys. Rev. A34 (1986) 2536
- 1986HU1D C.A. Hughes, S.D. Bloom and G.J. Mathews, Astrophys. J. 311 (1986) 485
- 1986ILZZ D.V. Ilin, A.A. Levkovsky and V.E. Sherman, in Kharkov (1986) 450

- 1986JA1E Jarime, Preprint LA-UR-86-3705 (1986)
- 1986JO1B S.E. Jones, A.N. Anderson, A.J. Caffrey, C.DeW van Siclen, K.D. Watts, J.N. Bradbury, J.S. Cohen, P.A.M. Gram, M. Leon, H.R. Maltrud et al., Phys. Rev. Lett. 56 (1986) 588
- 1986JO1C S.E. Jones, Sci. Rap. Inst. Phys. Chem. Res. 80 (1986) 17
- 1986KA1G O. Karban, J. Phys. Soc. Jpn. Suppl. 55 (1986) 774
- 1986KA1H M. Kamran and I.E. Qureshi, AIP Conf. Proc. 150 (1986) 729
- 1986KA1K B.M. Karnakov and V.D. Mur, Sov. J. Nucl. Phys. 44 (1986) 916
- 1986KA1L J. Kallne, O.N. Jarvis, V. Merlo, G. Gorini, G. Martin, G. Sadler and P. van Belle, Rept. JET-P(86)34 (1986)
- 1986KA28 H. Kanada, T. Kaneko, P.N. Shen and Y.C. Tang, Nucl. Phys. A457 (1986) 93
- 1986KA35 M. Kamran, J. Phys. (London) G12 (1986) L113
- 1986KE1H Kehayias, Ellis, Cohn and Weinlein, Bull. Amer. Phys. Soc. 31 (1986) 1290
- 1986KH1B Khersonsky, Zh. Eksp. Teor. Fiz. SSSR 91 (1986) 1172
- 1986KL04 H.O. Klages, F.P. Brady, P. Doll, R. Garrett, J. Hansmeyer, W. Heeringa, J.C. Hiebert, K. Hofmann, P. Jany, H. Krupp et al., Radiat. Eff. 94 (1986) 195; in Santa Fe 85 (1986) 869
- 1986KN1A R.J. Knize, J. Phys. Soc. Jpn. Suppl. 55 (1986) 412
- 1986KO1J Y. Koike, J. Phys. Soc. Jpn. Suppl. 55 (1986) 272
- 1986KO21 P. Kozma, Czech. J. Phys. B36 (1986) 786
- 1986KR12 A.T. Kruppa, R.G. Lovas, R. Beck and F. Dickmann, Phys. Lett. B179 (1986) 317
- 1986KU1G K. Kudo, T. Michikawa and T. Kinoshita, Nucl. Instrum. Meth. Phys. Res. A249 (1986) 339
- 1986LA1F J.S. Ladish, J.W. Toevs, C.S. Young, P. Nash, S. Iversen, P. Zagarino, L. Jennings and R.D. Seno, IEEE Trans. Nucl. Sci. 33 (1986) 385
- 1986LA29 J. Lang, Th. Maier, R. Muller, F. Nessi-Tedaldi, Th. Roser, M. Simonius, J. Sromicki and W. Haerberli, Phys. Rev. C34 (1986) 1545
- 1986LAZH J.B.J.M. Lanen, A.M. van den Berg, J.F.J. van den Brand, J.A. Hendriks, J.W.A. den Herder, E. Jans, P.H.M. Keizer, G.J. Kramer, L. Lapikas, E.N.M. Quint et al., in Harrogate (1986) 361, C174
- 1986LE1F Lees et al., in Santa Fe (1985) 1259
- 1986LI1L J. Liu, F. Kong and X. Liu, Chin. J. Nucl. Phys. 8 (1986) 88
- 1986LO1B Lovberg, Strachan and Heidbrink, in Santa Fe (1985) 245
- 1986MA1C L. Majling, J. Zofka, V.N. Fetisov and R.A. Eramzhyan, Nucl. Phys. A450 (1986) 189c

- 1986MA1V Magda, Pop and Sandulescu, in Harrogate (1986) C208
- 1986ME1D L.I. Menshikov and L.I. Ponomarev, Phys. Lett. B167 (1986) 141
- 1986MO05 G.L. Morgan, P.W. Lisowski, S.A. Wender, R.E. Brown, N. Jarmie, J.F. Wilkerson and D.M. Drake, Phys. Rev. C33 (1986) 1224
- 1986NI1B P. Niessen, M. Buballa, D. Gola, H.J. Hahn, B. Laumann, K.R. Nyga, H. Oswald, B. Polke, G. Rauprich, J. Schulte-Uebbing et al., J. Phys. Soc. Jpn. Suppl. 55 (1986) 794
- 1986OK06 I.P. Okhrimenko, Yad. Fiz. 44 (1986) 320; Sov. J. Nucl. Phys. 44 (1986) 204
- 1986OK1B S. Okuda, R. Taniguchi and M. Fujishiro, Nucl. Instrum. Meth. Phys. Res. B14 (1986) 304
- 1986OR03 G. Orlandini, M. Traini and M. Ericson, Phys. Lett. B179 (1986) 201
- 1986OS1D A. Osman, J. Phys. Soc. Jpn. Suppl. 55 (1986) 744
- 1986PA1G Pavlik and Winkler, INDC (AUS)-011/LI, INT (86)-6 (1986)
- 1986PE1H E. Pedretti, A. Fubini and C. Di Nicola, J. Phys. Soc. Jpn. Suppl. 55 (1986) 1048
- 1986PO06 D.N. Poenaru, W. Greiner, K. Depta, M. Ivascu, D. Mazilu and A. Sandulescu, At. Data Nucl. Data Tables 34 (1986) 423
- 1986PO1F Powell, Maglich and Neric, Bull. Amer. Phys. Soc. 31 (1986) 891
- 1986RA21 J. Rapaport, Radiat. Eff. 95 (1986) 223; in Santa Fe 85 (1986) 1229
- 1986RI01 R. Rieder, P.D. Barnes, B. Bassalleck, R.A. Eisenstein, G. Franklin, R. Grace, C. Maher, P. Pile, J. Szymanski, W.R. Wharton et al., Phys. Rev. C33 (1986) 614
- 1986RO1J R. Roy, J. Pouliot, P. Bricault, C. Rioux, R.J. Slobodrian, H.E. Conzett and R.M. Larimer, J. Phys. Soc. Jpn. Suppl. 55 (1986) 1142
- 1986SA05 A.N. Safronov, Ukr. Fiz. Zh. 31 (1986) 22
- 1986SA1J H. Sakaguchi, M. Yosoi, M. Nakamura, T. Noro, H. Sakamoto, T. Ichihara, M. Ierei, Y. Takeuchi, H. Togawa, T. Tsutsumi et al., J. Phys. Soc. Jpn. Suppl. 55 (1986) 61
- 1986SA1L T. Sakai, K. Hashimoto, M. Takei, M. Kurokawa, A. Manabe, K. Aoki, Y. Aoki, Y. Tagishi and K. Yagi, J. Phys. Soc. Jpn. Suppl. 55 (1986) 652
- 1986SA1M J.A. Sawicki, J. Nucl. Mater. A141-143 (1986) 327
- 1986SA30 H. Sato and Y. Okuhara, Phys. Rev. C34 (1986) 2171
- 1986SH1I S. Shinmura, Y. Akaishi and H. Tanaka, Prog. Theor. Phys. 76 (1986) 157
- 1986SH1K S. Shinmura, Nucl. Phys. A450 (1986) 147c
- 1986SH1V S.-H. Shi and X.-N. Jin, Commun. Theor. Phys. 5 (1986) 105
- 1986ST1D E. Stenlund, Nucl. Phys. A447 (1986) 181c
- 1986SZ1A J.J. Szymanski, AIP Conf. Proc. 150 (1986) 934
- 1986TA1J H. Takahashi, Fusion Technol. 9 (1986) 328

- 1986TA1K N.A. Tahir and K.A. Long, Z. Phys. A325 (1986) 99
- 1986TA1L H. Takahashi, J. Phys. G12 (1986) L271
- 1986TH1C S. Tharraketta, W. Arnold, H. Baumgart, J. Gunzl, A. Hofmann, E. Huttel, N. Kniest and G. Clausnitzer, J. Phys. Soc. Jpn. Suppl. 55 (1986) 880
- 1986VA1D W.T.H. van Oers, J. Phys.Soc. Jpn. Suppl. 55 (1986) 502
- 1986VAZU Vasilevskii, Gutich and Okhrimenko, in Kharkov (1986) 412
- 1986WA11 R.E. Warner, B.A. Vaughan, D.L. Friesel, P. Schwandt, J.-Q. Yang, G. Caskey, A. Galonsky, B. Remington and A. Nadasen, Nucl. Phys. A453 (1986) 605
- 1986WA1J X.-C. Wang, H. Takaki and H. Bando, Prog. Theor. Phys. 76 (1986) 865
- 1986WA21 Y. Wang, J. Chen and F. Huang, Nucl. Instrum. Meth. Phys. Res. B17 (1986) 11
- 1986WI04 D.H. Wilkinson, Nucl. Phys. A452 (1986) 296
- 1986WI1B D.R. Winn, IEEE Trans. Nucl. Sci. 33 (1986) 213
- 1986WI1E L.J. Wittenberg, J.F. Santarius and G.L. Kulcinski, Fusion Tech. 10 (1986) 167
- 1986XU1B H.M. Xu and W.G. Lynch, Int. Conf. on Nucl. Radiochem, 1-5 Sept. 1986, Beijing, China (1986) 54
- 1986YA01 A.M. Yasnogorodsky, Yad. Fiz. 43 (1986) 281; Sov. J. Nucl. Phys. 43 (1986) 178
- 1986YA1E A.M. Yasnogorodsky, J. Phys. Soc. Jpn. Suppl. 55 (1986) 882
- 1986YA1F Y. Yamamoto, Prog. Theor. Phys. 75 (1986) 639
- 1987AC1A P. Ackerbauer, J. Birstirlich, W.H. Breunlich, H. Bossy, M. Cargnelli, K.M. Crowe, H. Daniel, T. von Egidy, F.J. Hartmann, M. Jeitler et al., SIN Newsl. 19 (1987) 54
- 1987AK1B Y. Akaishi, M. Kamimura and H. Narumi, Z. Phys. A328 (1987) 115
- 1987AS05 H.J. Assenbaum, K. Langanke and C. Rolfs, Z. Phys. A327 (1987) 461
- 1987BA12 F. Balestra, M.P. Bussa, L. Busso, L. Fava, L. Ferrero, D. Panzieri, G. Piragino, F. Tosello, G. Bendiscioli, A. Rotondi et al., Nucl. Phys. A465 (1987) 714
- 1987BA2I Barnes and Cecil, Bull. Amer. Phys. Soc. 32 (1987) 1571
- 1987BA2L D.V. Balin, A.I. Ilyin, E.M. Maev, V.P. Maleev, A.A. Markov, V.I. Medvedev, G.E. Petrov, L.B. Petrov, C.G. Semenchuk, Yu.V. Smirenin et al., Muon Catalyzed Fusion 1 (1987) 127
- 1987BA2P D.V. Balin, V.A. Volchenkov, A.A. Vorob'ev, An.A. Vorob'ev, A.I. Il'in, V.K. Kapyshov, E.M. Maev, M.P. Malek, V.P. Maleev, A.A. Markov et al., Zh. Eksp. Teor. Fiz. 92 (1987) 1543; Sov. Phys. JETP 65 (1987) 866
- 1987BA47 F. Balestra, R. Barbieri, Yu.A. Batusov, G. Bendiscioli, S. Bossolasco, M.P. Bussa, L. Busso, I.V. Falomkin, L. Ferrero, C. Guaraldo et al., Phys. Lett. B194 (1987) 343
- 1987BA69 F. Balestra, S. Bossolasco, M.P. Bussa, L. Busso, L. Fava, L. Ferrero, D. Panzieri, G. Piragino, F. Tosello, G. Bendiscioli et al., Nucl. Phys. A474 (1987) 651



- 1987BE1W A. Bertin, M. Bruschi, M. Capponi, S. De Castro, I. Massa, M. Piccinini, M. Poli, N. Semprini-Cesari, A. Vitale and A. Zoccoli, *Europhys. Lett.* 4 (1987) 875
- 1987BE1Y A. Bertin, M. Capponi, S. De Castro, I. Massa, M. Piccinini, M. Poli, N. Semprini-Cesari, A. Vitale and A. Zoccoli, *Muon Catalyzed Fusion* 1 (1987) 151
- 1987BEYI A.V. Belozyorov, C. Borcea, Z. Dlouhy, A.M. Kalinin, Nguyen Hoai Chau and Yu.E. Penionzhkevich, *JINR-E15-87-733* (1987)
- 1987BL1K L.D. Blokhintsev, Kh.D. Razikov, M.K. Ubaidullaeva and R. Yarmukhamedov, *Izv. Akad. Nauk. SSSR Ser. Fiz.* 51 (1987) 189; *Bull. Acad. Sci. USSR Phys. Ser.* 51 (1987) 173
- 1987BO1L A.R. Bodmer and Q.N. Usmani, *Nucl. Phys.* A463 (1987) 221c
- 1987BO1O A.R. Bodmer and Q.N. Usmani, *Nucl. Phys.* A468 (1987) 653
- 1987BO1Q Bosch et al., *Bull. Amer. Phys. Soc.* 32 (1987) 1925
- 1987BO40 C. Borcea, A.V. Belozyorov, Z. Dlouhy, A.M. Kalinin, Nguyen Hoai Chau and Yu.E. Penionzhkevich, *Rev. Roum. Phys.* 32 (1987) 497
- 1987BR10 R.E. Brown, N. Jarmie and G.M. Hale, *Phys. Rev.* C35 (1987) 1999; *Erratum Phys. Rev.* C36 (1987) 1220
- 1987BR1G W.H. Breunlich, M. Cargnelli, P. Kammel, J. Marton, N. Naegele, P. Pawlek, A. Scrinzi, J. Werner, J. Zmeskal, J. Bistirlich et al., *Phys. Rev. Lett.* 58 (1987) 329
- 1987BR1T W.H. Breunlich, M. Cargnelli, P. Kammel, J. Marton, N. Naegele, P. Pawlek, A. Scrinzi, J. Werner, J. Zmeskal, J. Bistirlich et al., *Muon Catalyzed Fusion* 1 (1987) 67
- 1987BR1W W.H. Breunlich, *Muon Catalyzed Fusion* 1 (1987) 29
- 1987CA13 J. Carlson, K.E. Schmidt and M.H. Kalos, *Phys. Rev.* C36 (1987) 27
- 1987CA1O A.J. Caffrey, A.N. Anderson, C.DeW. Van Siclen, K.D. Watts, J.N. Bradbury, P.A.M. Gram, M. Leon, H.R. Maltrud, M.A. Paciotti and S.E. Jones, *Muon Catalyzed Fusion* 1 (1987) 53
- 1987CH32 Z. Chen, C.K. Gelbke, W.G. Gong, Y.D. Kim, W.G. Lynch, M.R. Maier, J. Pochodzalla, M.B. Tsang, F. Saint-Laurent, D. Ardouin et al., *Phys. Lett.* B199 (1987) 171
- 1987CH33 Z. Chen, C.K. Gelbke, W.G. Gong, Y.D. Kim, W.G. Lynch, M.R. Maier, J. Pochodzalla, M.B. Tsang, F. Saint-Laurent, D. Ardouin et al., *Phys. Rev.* C36 (1987) 2297
- 1987CO1N J.S. Cohen, *Phys. Rev. Lett.* 58 (1987) 1407; *Erratum Phys. Rev. Lett.* 58 (1987) 2154
- 1987CO1P J.S. Cohen, *Phys. Rev.* A35 (1987) 1419
- 1987CO1W J.S. Cohen, *Muon Catalyzed Fusion* 1 (1987) 179
- 1987DE1O Detraz, in *Dubna* (1987) 42
- 1987DO1H R. Dominguez-Tenreird and G. Yepes, *Astron. Astrophys.* 177 (1987) 5
- 1987DU07 J. Duflo, *Phys. Rev.* C36 (1987) 1425

- 1987DU09 E.I. Dubovoi and G.I. Chitanava, *Yad. Fiz.* 45 (1987) 677; *Sov. J. Nucl. Phys.* 45 (1987) 423
- 1987DU1B Dubovichenko and Zhusupov, in *Yurmala* (1987) 502
- 1987FA1I G. Fazio, S. Femino, G. Giardina, A. Italiano, F. Mezzanares and R. Palamara, *Hadronic J.* 10 (1987) 21
- 1987FO08 D. Fox, D.A. Cebra, J. Karn, C. Parks, G.D. Westfall and W.K. Wilson, *Phys. Rev. C* 36 (1987) 640
- 1987FO1C S. Forte, *Nucl. Phys. A* 467 (1987) 665
- 1987FR1D V. Franco, *Phys. Rev. C* 35 (1987) 1328
- 1987FU10 K. Fukunaga, S. Kakigi, T. Ohsawa, A. Okihana and T. Sekioka, *J. Phys. Soc. Jpn.* 56 (1987) 2357
- 1987GA20 A.K. Ganguly, B. Chaudhuri and B.B. Baliga, *Nuovo Cim. A* 97 (1987) 639
- 1987GE1B C.-K. Gelbke and D.H. Boal, *Prog. Part. Nucl. Phys.* 19 (1987) 33
- 1987GO25 M.G. Gornov, Yu.B. Gurov, V.P. Koptev, P.V. Morokhov, K.O. Oganessian, B.P. Osipenko, V.A. Pechkurov, V.I. Savelev, F.M. Sergeev, A.A. Khomutov et al., *Pisma Zh. Eksp. Teor. Fiz.* 45 (1987) 205; *JETP Lett. (USSR)* 45 (1987) 252
- 1987GOZF O.K. Gorpinich, E.P. Kadkin, S.N. Kondratev, L.S. Saltykov, V.D. Sklyarenko and V.V. Tokarevsky, in *Yurmala* (1987) 341
- 1987GR08 W. Gruebler, *Nucl. Phys. A* 463 (1987) 193c
- 1987HA20 G.M. Hale, R.E. Brown and N. Jarmie, *Phys. Rev. Lett.* 59 (1987) 763
- 1987HA44 G.M. Hale, R.E. Brown and N. Jarmie, *Phys. Rev. Lett.* 59 (1987) 2819
- 1987HA45 D. Hahn and H. Stocker, *Phys. Rev. C* 35 (1987) 1311
- 1987HU02 J.R. Hurd, J.S. Boswell, R.C. Minehart, L.B. Rees, Y. Tzeng, H.J. Ziock and K.O.H. Ziock, *Nucl. Phys. A* 462 (1987) 605
- 1987JO1A S.E. Jones, *Muon Catalyzed Fusion* 1 (1987) 21
- 1987KA1M Karmanov et al., in *Yurmala* (1987) 509
- 1987KA1O J. Kallne, G. Gorini, O.N. Jarvis, G. Martin, V. Merlo, G. Sadler and P. van Belle, *Phys. Scr. T* 16 (1987) 160
- 1987KA1Q G. Karl and J.V. Noble, *Phys. Rev. C* 36 (1987) 869
- 1987KA1Z M. Kamimura, *Muon Catalyzed Fusion* 1 (1987) 333
- 1987KAZL F. Kadirov, M.A. Kayumov, Sh. Kayumov, A.M. Mukhamedzhanov, U.I. Faizullaev, K. Khamidova and R. Yarmukhamedov, in *Yurmala* (1987) 343
- 1987KI16 A. Kiss, C. Mayer-Boricke, M. Rogge, P. Turek and S. Wiktor, *J. Phys. G* 13 (1987) 1067
- 1987KO1R V.I. Korobov, I.V. Puzynin and S.I. Vinitzky, *Phys. Lett. B* 196 (1987) 272

- 1987KO47 A.A. Korshennikov, E.Yu. Nikolsky and A.A. Ogloblin, *Pisma Zh. Eksp. Teor. Fiz.* 46 (1987) 306; *JETP Lett. (USSR)* 46 (1987) 384
- 1987KR16 D. Krolle, K. Langanke and C. Rolfs, *Z. Phys.* A328 (1987) 291
- 1987KR18 A. Krauss, H.W. Becker, H.P. Trautvetter, C. Rolfs and K. Brand, *Nucl. Phys.* A465 (1987) 150
- 1987KUZU V.I. Kukulín, in *Yurmala* (1987) 151
- 1987LE1G V.E. Lewis and T.B. Ryves, *Nucl. Instrum. Meth. Phys. Res.* A257 (1987) 462
- 1987LI07 J. Li, H. Lu, H. Ma, W. Zhao, Y. Cui, P. Fan and D. Wang, *Nucl. Instrum. Meth. Phys. Res.* A255 (1987) 115
- 1987LI1K Y. Liu and Y.-G. Li, *Phys. Energ. Fortis and Phys. Nucl.* 11 (1987) 68
- 1987LI1L Y.-G. Li, *Phys. Energ. Fortis and Phys. Nucl.* 11 (1987) 208
- 1987LY04 W.G. Lynch, *Nucl. Phys.* A471 (1987) 309c
- 1987LY1C Lyovshin and Fursa, in *Yurmala* (1987) 499
- 1987ME1E L.I. Menshikov and L.I. Ponomarev, *JETP Lett.* 46 (1987) 312
- 1987MI1N Miyagawa et al., in *Panic* (1987) 286
- 1987MI34 S. Micek, H. Rebel, H.J. Gils, H. Klewe-Nebenius, S. Zagromski and D.K. Srivastava, *Z. Phys.* A328 (1987) 467
- 1987MI38 M. Mian, *Phys. Rev.* C35 (1987) 1463
- 1987MO1K D. Morgan, M.R. Pennington, G.M. Hale, R.E. Brown and N.Jarmie, *Phys. Rev. Lett.* 59 (1987) 2818
- 1987MU1B R.J. Murphy, C.D. Dermer and R. Ramaty, *Astrophys. J. Suppl.* 63 (1987) 721
- 1987MUZZ K. Murphy, L.C. Bland, J. Breeden, W.W. Jacobs, B. Raue, J. Sowinski, J.A. Templeton, S.E. Vigdor and J.Wilkerson, *Bull. Amer. Phys. Soc.* 32 (1987) 1058
- 1987NA1K Nagamine et al., in *Panic* (1987) 816
- 1987NA23 V.I. Nazaruk, *Yad. Fiz.* 46 (1987) 80; *Sov. J. Nucl. Phys.* 46 (1987) 51
- 1987OT1D I. Otterlund, *Nucl. Phys.* A461 (1987) 113c
- 1987PE1B Peter, in *Dubna* (1987) 562
- 1987PE1C Penionshkevich, in *Dubna* (1987) 364
- 1987PE1D C. Petitjean, W.H. Breunlich, M. Cargnelli, P. Kammel, J. Marton, N. Nagele, P. Pawlek, A. Scrinzi, J. Werner, J. Zmeskal et al., *Muon Catalyzed Fusion* 1 (1987) 89
- 1987PO03 J. Pochodzalla, C.K. Gelbke, W.G. Lynch, M. Maier, D. Ardouin, H. Delagrangé, H. Doubre, C. Gregoire, A. Kyanowski, W. Mittig et al., *Phys. Rev.* C35 (1987) 1695
- 1987PO1G Pomerantsev and Kukulín, in *Yurmala* (1987) 501
- 1987PO1H B. Povh, *Prog. Part. Nucl. Phys.* 18 (1987) 183

1987PO1M L.I. Ponomarev and G. Fiorentini, Muon Catalyzed Fusion 1 (1987) 3  
 1987PR08 S. Pratt and M.B. Tsang, Phys. Rev. C36 (1987) 2390  
 1987QI01 Z. Qiu, Y. Wang and J. Chen, Chin. J. Nucl. Phys. 9 (1987) 10  
 1987RA1L H. Rafelski, B. Muller, J. Rafelski, D. Trautmann, R.D. Viollier and M. Danos, Muon Catalyzed Fusion 1 (1987) 315  
 1987RIZZ J.C. Riley, H.R. Weller and D.R. Tilley, Bull. Amer. Phys. Soc. 32 (1987) 1547  
 1987RO25 C. Rolfs, H.P. Trautvetter and W.S. Rodney, Rept. Prog. Phys. 50 (1987) 233  
 1987SH09 P.N. Shen and Y.C. Tang, Phys. Rev. C35 (1987) 1985; Erratum Phys. Rev. C36 (1987) 1220  
 1987SH1H S. Shinmura, Nucl. Phys. A463 (1987) 215c  
 1987SO04 S.A. Sofianos, Phys. Rev. C35 (1987) 894  
 1987SO1A Souers et al., Bull. Amer. Phys. Soc. 32 (1987) 32  
 1987SO1C Soundranayagam, Seth and Parker, in Panic (1987) 292  
 1987SV1A V.A. Sviciulis and R.K. Kalinauskas, Sov. Phys.-Collect. 27 (1987) 10  
 1987TA1I N. Takigawa and B. Muller, Muon Catalyzed Fusion 1 (1987) 341  
 1987TE1D Ter Nersesyants, in Yurmala (1987) 540  
 1987TEZZ J.A. Templon, L.C. Bland, J. Breeden, W.W. Jacobs, K. Murphy, B. Raue, J. Sowinski, S.E. Vigdor and J. Wilkerson, Bull. Amer. Phys. Soc. 32 (1987) 1058  
 1987US1A Ustinin and Efros, in Yurmala (1987) 503  
 1987VA36 V.S. Vasilevsky, I.F. Gutich and I.P. Okhrimenko, Yad. Fiz. 46 (1987) 757; Sov. J. Nucl. Phys. 46 (1987) 427  
 1987WA11 Y. Wang, J. Chen and F. Huang, Chin. J. Nucl. Phys. 9 (1987) 89  
 1987WA21 R.E. Warner, B.A. Vaughan, J.A. Ditusa, J.W. Rovine, R.S. Wakeland, C.P. Browne, S.E. Darden, S. Sen, A. Nadasen, A. Basak et al., Nucl. Phys. A470 (1987) 339  
 1987WA25 R.E. Warner, F.G. Johnson, C.P. Browne, A. Rollefson, A. Galonsky and A. Nadasen, Nucl. Phys. A472 (1987) 522  
 1987WU1C Wuethrich et al., Bull. Amer. Phys. Soc. 32 (1987) 1925  
 1987WY1A D.R. Wyman, R.E. Stone and A.A. Harms, Nucl. Sci and Eng. 96 (1987) 46  
 1987YA1C Yamamoto, in Panic (1987) 582  
 1987YA1M Y. Yamamoto, Phys. Rev. C36 (1987) 2166  
 1987YAZJ A.M. Yasnogorodsky, V.V. Ostashko, V.N. Urin and A.N. Nenakhov, in Yurmala (1987) 321  
 1987ZA07 M. Zadro, D. Miljanic, M. Lattuada, F. Riggi and C. Spitaleri, Nucl. Phys. A474 (1987) 373

- 1987ZE1D F.-A. Zeng and X. Zhao, Phys. Energ. Fortis and Phys. Nucl. 11 (1987) 120
- 1987ZW1A Zweben, Bull. Amer. Phys. Soc. 32 (1987) 1571
- 1988AR05 N. Arena, Seb. Cavallaro, G. Fazio, G. Giardina, A. Italiano and F. Mezzanares, Eu-  
rophys. Lett. 5 (1988) 517
- 1988BA1G P.D. Barnes, Nucl. Phys. A479 (1988) 89c
- 1988BA75 F.C. Barker, Aust. J. Phys. 41 (1988) 743
- 1988BA86 J.N. Bahcall and R.K. Ulrich, Rev. Mod. Phys. 60 (1988) 297
- 1988BAZH I.Ya. Barit, S.V. Zuev, V.A. Simonov and A.M. Yasnogorodsky, in Baku (1988) 277
- 1988BEYJ A.V. Belozerov, K. Borcha, I. Vintsour, Z. Dlougy, Nguen Khoai Tyau and Yu.Eh.  
Penionzhkevich, in Baku (1988) 380
- 1988BO1E A.R. Bodmer and Q.N. Usmani, Nucl. Phys. A477 (1988) 621
- 1988BU04 S. Burzynski, J. Turkiewicz, K. Rusek, I.M. Turkiewicz and P. Zupranski, Nucl. Phys.  
A480 (1988) 51
- 1988CA11 P.J. Carlos, Ph. Bourgeois, J. Fagot, J.L. Fallou, P. Garganne, J.M. Laget, A. Lepretre,  
A. de Miniac, A. Veysiére, J. Jury et al., Phys. Lett. B203 (1988) 33
- 1988CEZZ D.A. Cebra, W. Benenson, Y. Chen, E. Kashy, D.J. Morrissey, A. Pradhan, A. Van-  
dermolen, G.D. Westfall, W.K. Wilson, R.S. Tickle et al., Bull. Amer. Phys. Soc. 33  
(1988) 963, DI12
- 1988EN03 S. Engstler, A. Krauss, K. Neldner, C. Rolfs, U. Schroder and K. Langanke, Phys.  
Lett. B202 (1988) 179
- 1988FR06 V. Franco and A. Tekou, Phys. Rev. C37 (1988) 1097
- 1988GU1G Gusinsky et al., in Baku (1988) 517
- 1988HE1C E.M. Henley, Interactions and Structures in Nuclei, Proc. in Honor of D.H. Wilkinson,  
Sussex, Sept. 7-9, 1987 (1988) 151
- 1988JA1C M. Jandel, M. Danos and J. Rafelski, Phys. Rev. C37 (1988) 403
- 1988KI1C Kiptily, in Baku (1988) 534
- 1988KU1E Kukulin, in Baku (1988) 396
- 1988KW02 E. Kwasniewicz and J. Kisiel, Acta Phys. Pol. B19 (1988) 141
- 1988LA1B K. Langanke and T. Warmann, Phys. Rev. C37 (1988) 1656
- 1988LI1C H.J. Lipkin, Nucl. Phys. A478 (1988) 307c
- 1988NA18 V.A. Nazarenko, J. Phys. (London) G14 (1988) S381
- 1988NO1A Noda and Steshenko, in Baku (1988) 165
- 1988PA1E Pasechnik, in Baku (1988) 296
- 1988PO1H B. Povh, Prog. Part. Nucl. Phys. 20 (1988) 353

- 1988PUZZ V. Punjabi, C.F. Perdrisat, C. Lyndon, P. Ulmer, J. Yonnet, R. Beurtey, M. Boivin, A. Boudard, F. Plouin, J.P. Didelez et al., Bull. Amer. Phys. Soc. 33 (1988) 962
- 1988RO1G R.E. Robson, J. Chem. Phys. 88 (1988) 198
- 1988SA09 F. Saint-Laurent, A. Kyanowski, D. Ardouin, H. Delagrance, H. Doubre, C. Gregoire, W. Mittig, A. Peghaire, J. Peter, G. Bizard et al., Phys. Lett. B202 (1988) 190
- 1988SEZJ K.K. Seth, AIP Conf. Proc. 164 (1988) 324
- 1988STZZ S.M. Sterbenz, D. Dehnhard, M.K. Jones, C.E. Parman, Y.F. Yen, K.W. Jones and S.K. Nanda, Bull. Amer. Phys. Soc. 33 (1988) 961
- 1988TA29 H. Tamura, W. Bruckner, H. Dobbeling, R.S. Hayano, T. Ishikawa, M. Iwasaki, T. Motoki, H. Outa, S. Paul, B. Povh et al., Nucl. Phys. A479 (1988) 161c
- 1988US1B Ustinin and Efros, in Baku (1988) 401
- 1988WA08 F. Wang, C.W. Wong and S.-Q. Lu, Nucl. Phys. A480 (1988) 490
- 1988WO04 A.A. Wolters, A.G.M. van Hees and P.W.M. Glaudemans, Europhys. Lett. 5 (1988) 7
- 1988WO10 C.L. Woods, F.C. Barker, W.N. Catford, L.K. Fifield and N.A. Orr, Aust. J. Phys. 41 (1988) 525

